

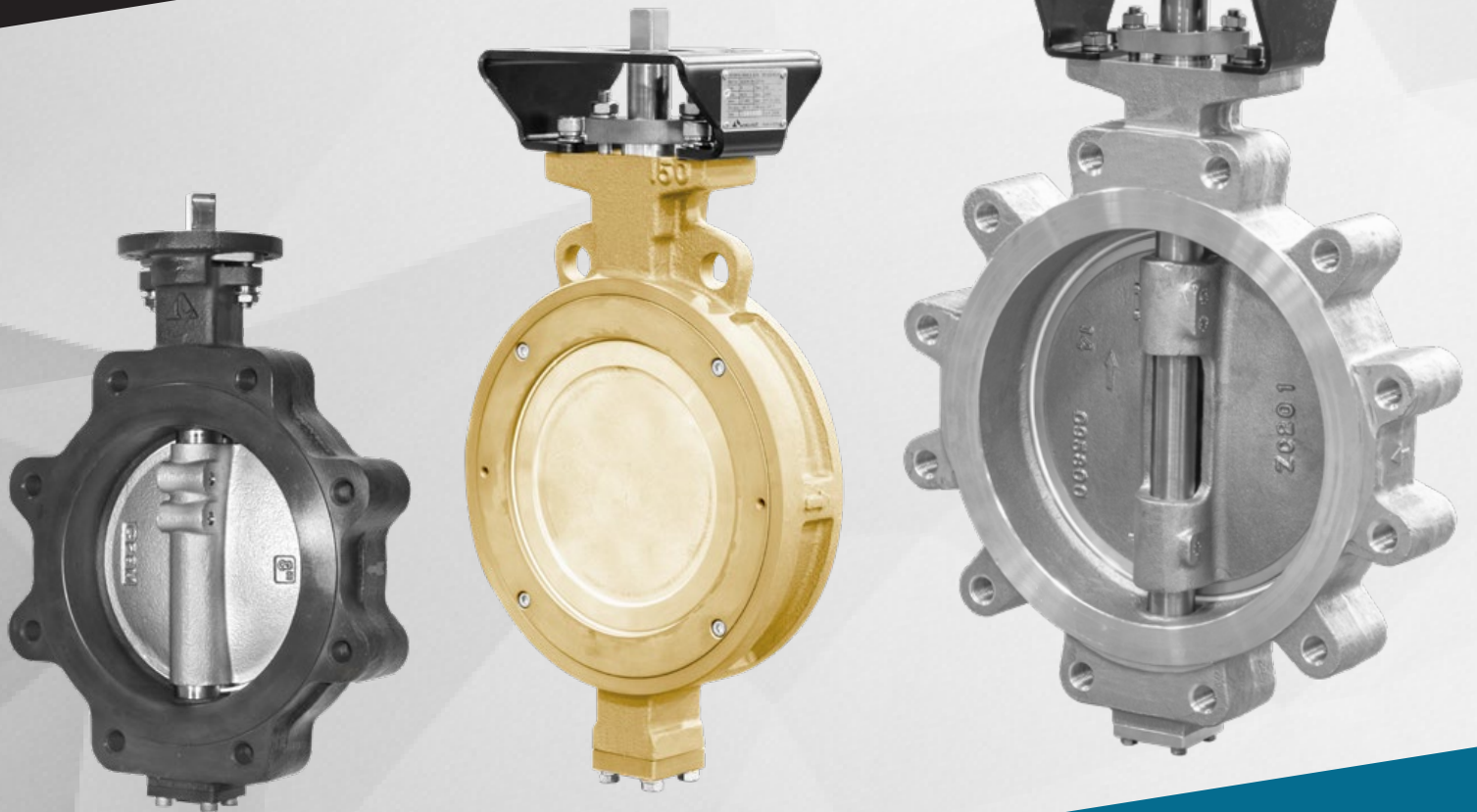

*Direct
Mount*



800 Series
HIGH PERFORMANCE BUTTERFLY VALVES
2" Through 24" Sizes, Class 150, 300, & 600 Double Offset Valves





CE Marking

is a mandatory conformity marking for certain products sold within the European Economic Area (EEA) since 1985. The CE marking is also found on products sold outside the EEA that are manufactured in, or designed to be sold in, the EEA. This makes the CE marking recognizable worldwide even to people who are not familiar with the European Economic Area. It is in that sense similar to the FCC Declaration of Conformity used on certain electronic devices sold in the United States. The CE marking is the manufacturer's declaration that the product meets the requirements of the applicable EC directives.



ISO 5211:

This standard defines a standardized interface system between industrial valves and the part turn actuators used operate them. It details the dimensional requirements for both the mounting flanges on both devices as well as the driving and driven components. This standardization simplifies the design of or eliminates the need for interface components between part turn valves and actuators.



ISO 15848-1

Fugitive Emissions

Our valves are equipped with packing arrangements which comply with this standards requirements for fugitive emissions.



API 607 Fire-Safe

Our fire safe trim valves have been tested by independent third party laboratories and proven to meet the requirements of the 7th edition of this standard.

Standards & Compliance on Standard Products

- **API 609** – Designed in full compliance with this governing standard and MSS SP-68
- **API 598 / MSS SP61** – All valves tested in compliance
- **ASME B16.34** – Design compliance
- **API 607** – Designed in compliance with independent 3rd party testing
- **ASME B16.5** – Flange dimension compliance
- **ASME / FCI 70-2** Seat leakage compliance
- **ISO 15848-1** – Fugitive Emissions compliance
- **MSS SP-25** – Marking compliance



API 609

API 609 is the governing standard for butterfly valve design. Our valves are designed in full compliance with this standard and as such, also comply with the other relevant design and testing standards including MSS SP61, SP25, ASME B16.34, API 598, and others.

3-Year Limited Warranty

Max-Air Technology, Inc., hereinafter referred to as "MAX-AIR", provides the following limited 3-year manufacturer's warranty regarding all Delta T brand labeled quarter turn valve products manufactured by MAX-AIR. This warranty includes all valves which are manufactured by MAX-AIR and only applies to those items which are clearly identified as Delta T brand labeled products. The warranty stated herein is expressly in lieu of all other warranties and representations, expressed or implied, or statutory, including, without limitation, the implied warranty of fitness for a particular purpose.

MAX-AIR warrants its products to be free from defects in materials and workmanship when these products are used for the purpose for which they were designed and manufactured. MAX-AIR does not warrant its products against chemical or stress corrosion or against any other failure other than from defects in materials or workmanship. The warranty period is for thirty-six months from the delivery date by MAX-AIR to its customers. Any claims regarding this warranty must be in writing and received by MAX-AIR before the last effective date of the warranty period.

Upon receipt of a warranty claim, MAX-AIR reserves the right to inspect the product(s) in question at either the field location or at a MAX-AIR designated facility. If, after the inspection of the product(s) in question, MAX-AIR determines that the purchaser's claim is covered by this warranty, MAX-AIR's sole liability and the purchaser's sole remedy under this warranty is limited to the refunding of the purchase price or repair or replacement thereof, at the sole discretion of MAX-AIR.

MAX-AIR will not be liable for any repairs, labor, material, or other expenses that are not specifically authorized in writing by MAX-AIR, and in no event shall MAX-AIR be liable for any direct or consequential damages arising out of any defect from any cause whatsoever. If any Delta T brand labeled products are modified or altered in any way, without the expressed written consent of MAX-AIR, the products will not be covered by this warranty.

MAX-AIR shall not be liable for any incidental, consequential or other damages, costs, or economic losses, including, without limitation, any resulting from labor charges, delays, vandalism, negligence, fouling caused by foreign material damage from adverse flow conditions, chemicals, or acts of God, or circumstances that are not controllable or reasonably foreseeable by MAX-AIR.

This warranty shall be invalidated in all circumstances where MAX-AIR, acting reasonably, determines that the product(s) was subject to abuse, misuse, neglect, or improper application, installation, alteration or modification not authorized in writing by MAX-AIR. All claims received by MAX-AIR beyond the warranty period are invalid and shall not be accepted.

Except for the express written warranty contained herein, MAX-AIR does not make any other warranty, condition, guarantee, or indemnity, express or implied, statutory or otherwise, regarding the products including without limitation, to the extent permitted by law, any warranty or merchantability or fitness for a particular purpose. All other warranties, conditions, guarantees and indemnities regarding any products are hereby disclaimed, excluded and overwritten.



Contents

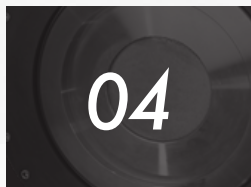

Features & Materials

Features, Benefits, Exploded View, & Materials

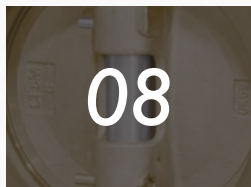

Dimensions

*Wafer, Lug, & Flanged Body Styles
Class 150, 300, & 600 Dimensions*

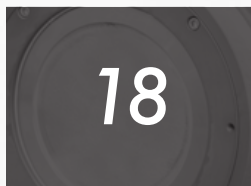

Technical Data

*Torques, Cv Values, Pressure Temperature
Chart, & Part Number Builder*

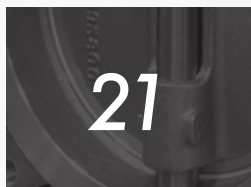

Ordering Guideline

Ordering Guideline & Crossover

High Performance Butterfly Valve Features & Benefits

ISO Bracket Mount
Included for 14" - 24"

ISO Direct Mount
for 2" - 12"

ISO 5211
DIRECT MOUNT

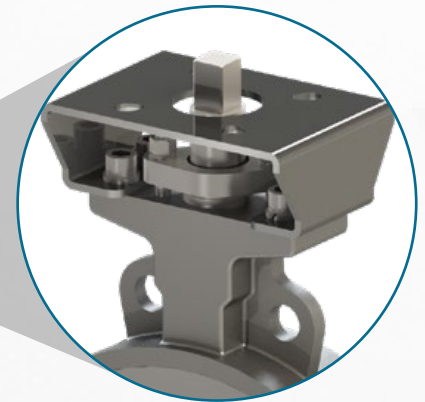

**EASY-ADJUST
PACKING GLAND**
Accessible with
actuator mounted
in place.

**BLOWOUT PROOF
STEM RETENTION**

Hard Stop
Internal Body Stop

SEAT INSERT
Supports the
seat and allows
for easy changeout.

PRECISION CAST BODY
Available in Lug and Wafer
Style, WCB or CF8M.

PTFE LINED SS BEARINGS
Supports stem and
increases service life.

PACKING

EXTENDED NECK
For pipe insulation.

SELF-ENERGIZED SEAT

One-piece design energizes without
secondary components such as
o-rings, springs or wires, resulting in
longer life and reduced maintenance.

TAPER PINS

Welded in place
after assembly
and testing.

DOUBLE OFFSET DISC

Eccentric design limits seat
contact through range of
motion, reducing torque
requirements. Standard
CF8M Material.

**Exotic Alloys
Are Our Specialty**

Our High Performance
Butterfly Valves are
available in special
materials including
Aluminum Bronze,
Duplex SS, Super
Duplex, Inconels,
Incolloys, etc.



Delta T High Performance Valves

Delta T High Performance Butterfly Valves are designed for demanding applications. Unique seat and body construction allows for easy configurability and maintenance, without compromising shut off capability or service life.

Features & Benefits

- ANSI 150, 300, & 600 in all styles
- Wafer, Lugged, & Flanged styles
- WCB & CF8M bodies stocked
(A broad selection of other materials available)
- Blow out proof stem design
- Stainless Steel disc & stem standard on stocked trims
- TFM 1600 seats are standard, other soft seats are available
- Fire Safe & Metal seated versions are available
- ISO 5211 mounting is standard.
(Direct mount for 12" & smaller,
w/ included bracket on larger size)
- Class VI / bubble tight bi-directional sealing on
all soft seated trims
- Dead End service to full pressure rating in preferred direction
- Control trim w/ anti-noise & anti-cavitation features available

Series Designations

- 850 - CLASS 150 - ANSI/DIN WAFER
- 851 - CLASS 150 - ANSI LUG
- 852 - CLASS 150 - DIN LUG
- 853 - CLASS 150 - ISO 5752 FLANGED (SHORT)
- 860 - CLASS 300 - ANSI/DIN WAFER
- 861 - CLASS 300 - ANSI LUG
- 862 - CLASS 300 - DIN LUG
- 863 - CLASS 300 - ISO 5752 FLANGED (SHORT)
- 871 - CLASS 600 - ANSI LUG

800 Series Exploded View Exploded View & Bill of Materials

Rev A

Rev A: ISO Direct Mount 2"-12"
Flanged Stop Plate Design

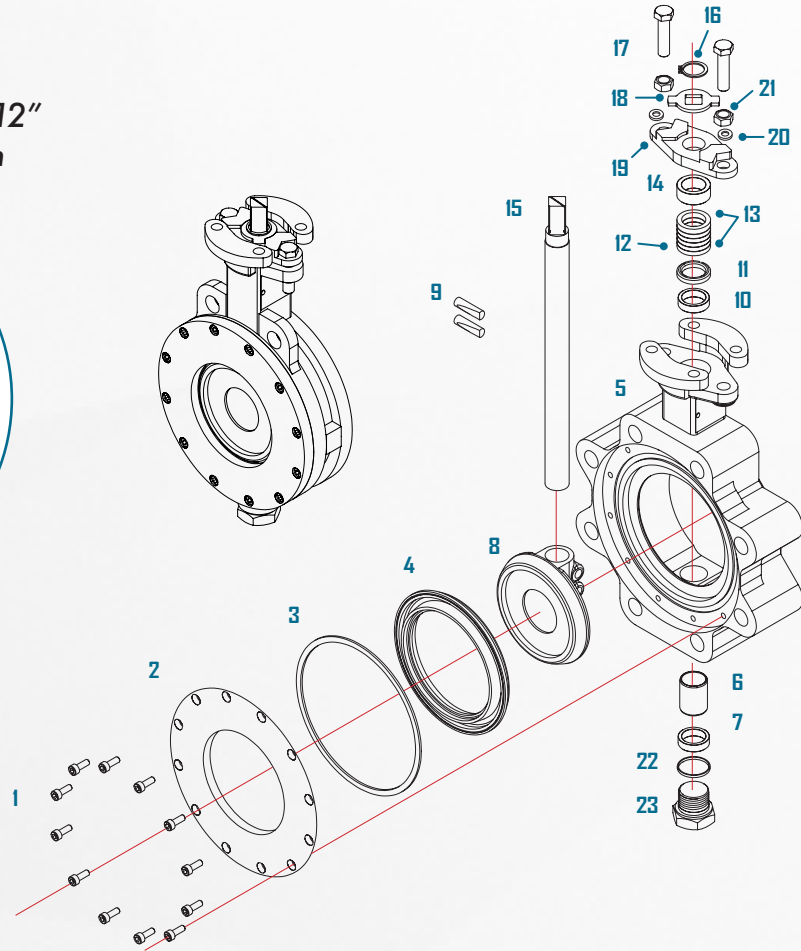
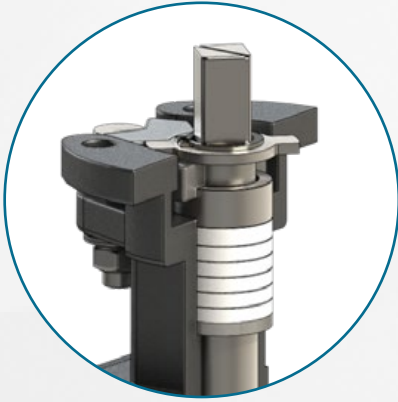

Bill of Materials

#	Part	Materials	Material Standard
1	Insert Bolts	304 SS	A193 GR. B8
2	Seat Insert	Carbon Steel	ASTM A29 GR1045
		Stainless steel	ASTM A240 GR316
3	Insert Ring	PTFE	n/a
4	Seat	TFM 1600	TFM 1600
5	Body	Carbon Steel	ASTM A216 Gr. WCB
		Stainless steel	ASTM A351 Gr. CF8M
6	Lower Stem Bearing	SS/PTFE Lined	n/a
7	Lower Retaining Ring	304 SS	ASTM A276
8	Disc	Stainless steel	ASTM A351 Gr. CF8M
9	Disc Taper Pins	17-4 PH	ASTM A564 Gr. 630
10	Lower Retaining Ring	304SS	ASTM A276

#	Part	Materials	Material Standard
11	Upper Stem Bearing	SS/PTFE Lined	n/a
12	Packing Ring	304 SS	ASTM A276
13	Packing	PTFE	n/a
14	Upper Retaining Ring	304 SS	ASTM A276
15	Stem	17-4 PH	ASTM A564 Gr. 630
16	Snap Ring	Plated carbon steel	W1-8
17	Gland Bolts	304 SS	A193 GR. B8
18	Stopper Plate	304 SS	ASTM A240
19	Packing Gland	Stainless steel	A351 CF8M
20	Spring Washers	301 SS	ASTM A240
21	Gland Nuts	304 SS	A194 GR. B8
22	Plug Seal	PTFE	n/a
		Carbon Steel	A216 WCB
23	Body Plug	Carbon Steel	A216 WCB
		Stainless steel	A351 CF8M



800 Series Exploded View Exploded View & Bill of Materials

Rev B

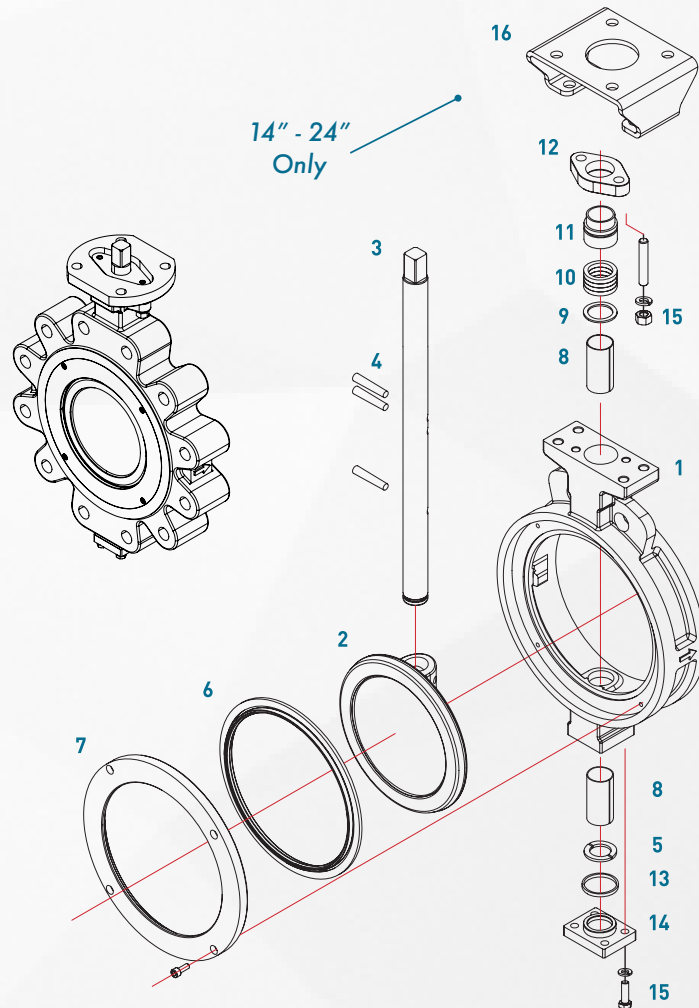

Bill of Materials

#	Part	Materials	Material Standard
1	Body	Carbon Steel	ASTM A216 WCB
		Stainless Steel	ASTM A351 CF8M
		Aluminium Bronze	ASTM B148 C95800
2	Disc	Stainless Steel	ASTM A351 CF8M
		Aluminium Bronze	ASTM B148 C95800
		Hard Facing	HCR, Stellite or ENP
3	Stem	Stainless Steel	ASTM A240 304, 316, 420
		17-4PH	ASTM A564 630
		K500 Monel	ASTM B865 NO5500
4	Disc Pin	17-4PH	ASTM A564 630
		Stainless Steel	ASTM A240 304, 316, 420
5	Stem Retainer	Stainless Steel	ASTM A240 304, 316
6	Seat	PTFE	Virgin PTFE
		TFM 1600	TFM 1600
		RTFE	Reinforced PTFE
		Metal Seat	316 SS, Inconel 625, Incoloy 825
		Fire Safe	RTFE/316SS, TFM1600/316SS

#	Part	Materials	Material Standard
7	Retainer Ring	Carbon Steel	ASTM A36
		Stainless Steel	ASTM A240 304, 316
		Aluminium Bronze	ASTM B148 C95400/ C95800
8	Bushing	316SS + PTFE	
9	Packing Retainer	Stainless Steel	ASTM A240 316
10	Packing	PTFE / RTFE - V Packing	
		Graphite	
11	Gland	Stainless Steel	ASTM A351 CF8
12	Gland Bridge	Stainless Steel	ASTM A351 CF8
13	Bottom Packing	PTFE / RTFE	
		Graphite	
14	Bottom Plate	Stainless Steel	ASTM A351 CF8
15	Bolt	ASTM A193 B8	
16	Bracket	Carbon Steel	Stainless Steel

850 (Class 150) Wafer 2" - 12" Dimensions

Rev A

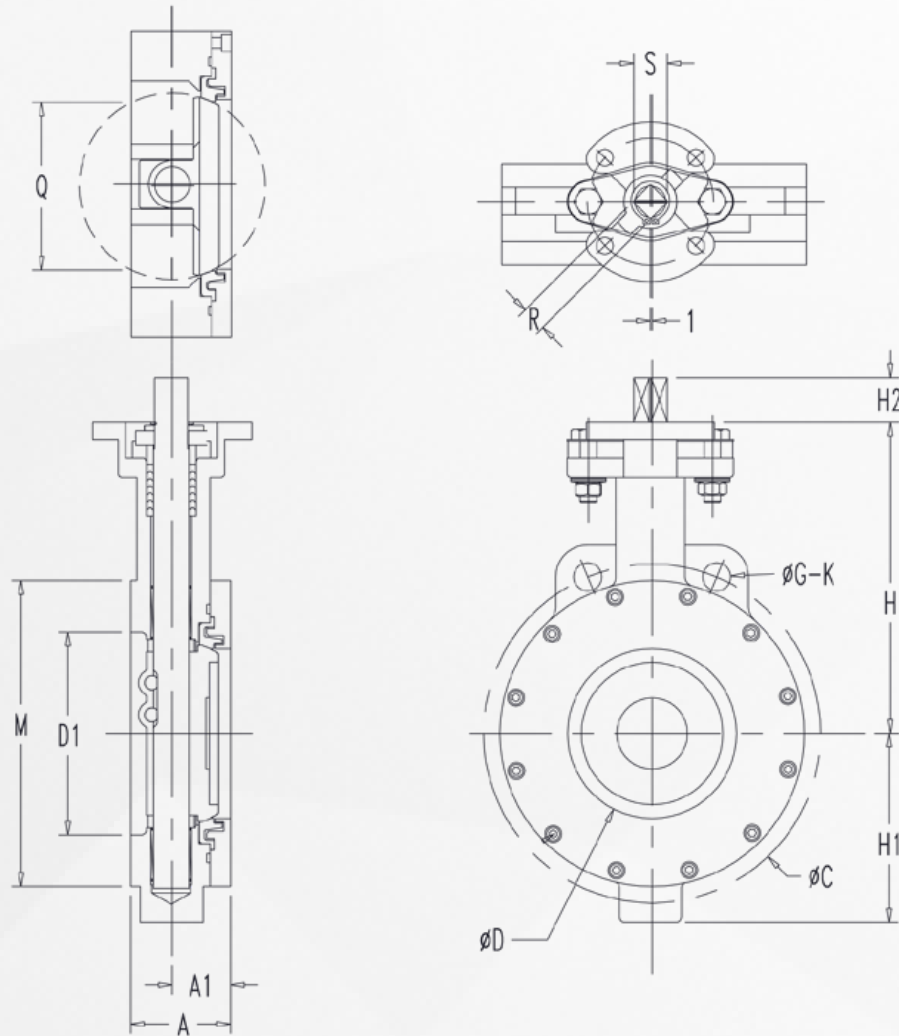

850 Series Rev A | Class 150 Wafer (Units in Inches)

Size	ISO 5211	A	A1	ØC	ØD	ØD1	G	K	H	H1	H2	M	Q	ØS	□R	Handle Size
2"	F07	1.81	1.14	4.75	1.81	2.28	0.67	2	5.00	3.00	0.71	3.62	1.80	0.55	0.43	HPH-01
2.5"	F07	1.93	1.06	5.50	2.32	2.72	0.67	2	5.51	3.79	0.83	4.13	1.97	0.56	0.43	HPH-01
3"	F07	2.01	1.18	6.00	2.87	3.31	0.67	2	5.91	4.21	0.83	5.00	2.80	0.71	0.55	HPH-02
4"	F07	2.22	1.32	7.50	3.76	4.17	0.71	2	6.89	4.68	0.83	6.18	3.71	0.74	0.55	HPH-02
5"	F10	2.32	1.34	8.50	4.37	4.72	0.81	2	7.87	5.12	1.10	7.32	4.21	0.74	0.55	HPH-03
6"	F10	2.36	1.38	9.50	5.59	6.06	0.79	2	8.46	5.71	1.10	8.50	5.53	0.74	0.55	HPH-03
8"	F10	2.56	1.50	11.75	7.48	7.95	0.81	2	9.65	7.06	1.46	10.67	7.48	1.02	0.75	HPH-04
10"	F10/F12	2.83	1.65	14.25	9.29	9.76	0.93	2	11.34	8.23	1.46	12.76	9.29	1.18	0.87	HPH-05
12"	F12	3.27	1.85	17.00	11.11	11.65	1.00	2	12.99	9.84	1.89	15.00	11.08	1.42	1.06	HPH-06



851 (Class 150) Lug 2" - 12" Dimensions

Rev A

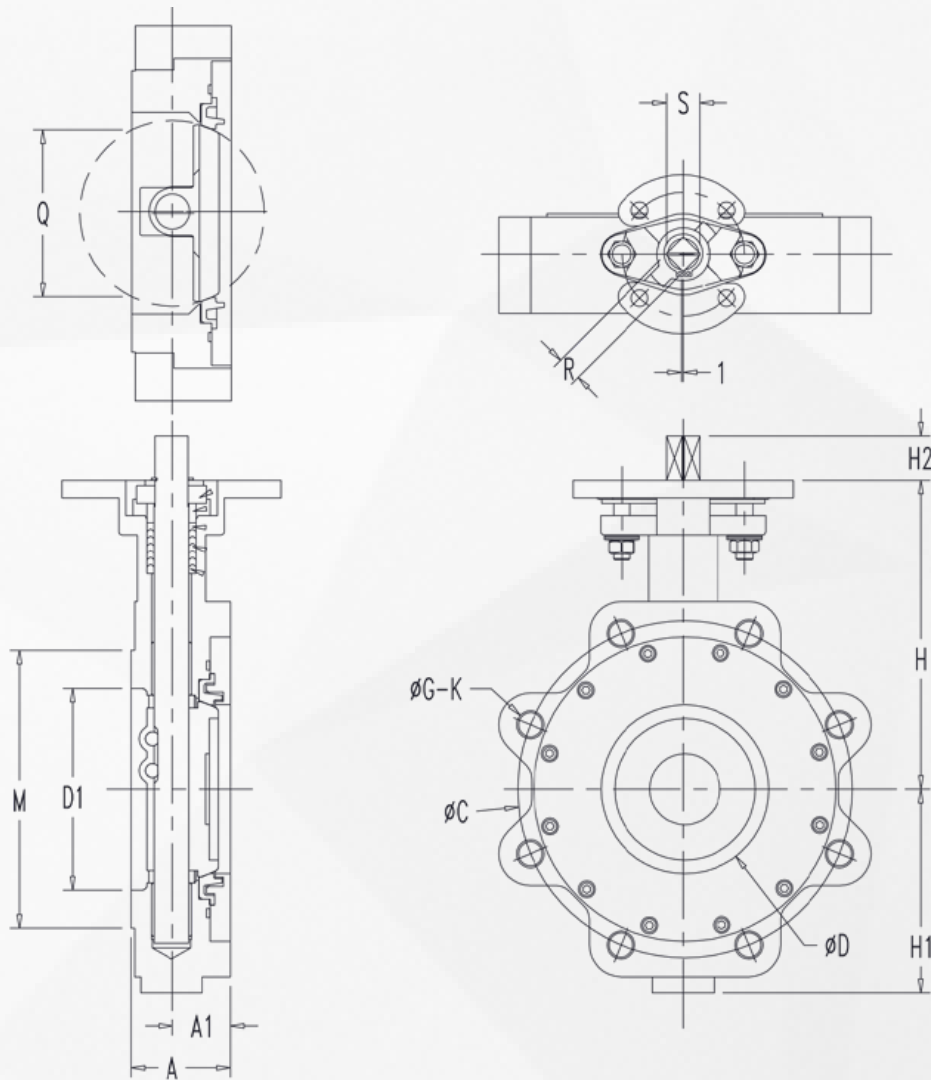

850 Series Rev A | Class 150 Lug (Units in Inches)

Size	ISO 5211	A	A1	ØC	ØD	ØD1	G	K	H	H1	H2	M	Q	ØS	□R	Handle Size
2"	F07	1.81	1.14	4.75	1.81	2.28	5/8"-11 UNC	4	5.00	3.00	0.71	3.62	1.80	0.55	0.43	HPH-01
2.5"	F07	1.93	1.06	5.50	2.32	2.72	5/8"-11 UNC	4	5.51	3.79	0.83	4.13	1.97	0.56	0.43	HPH-01
3"	F07	2.01	1.18	6.00	2.87	3.31	5/8"-11 UNC	4	5.91	4.21	0.83	5.00	2.80	0.71	0.55	HPH-02
4"	F07	2.22	1.32	7.50	3.76	4.17	5/8"-11 UNC	8	6.89	5.02	0.83	6.18	3.71	0.74	0.55	HPH-02
5"	F10	2.32	1.34	8.50	4.37	4.72	3/4"-10 UNC	8	7.87	5.44	1.10	7.32	4.21	0.74	0.55	HPH-03
6"	F10	2.36	1.38	9.50	5.59	6.06	3/4"-10 UNC	8	8.46	6.10	1.10	8.50	5.53	0.74	0.55	HPH-03
8"	F10	2.56	1.50	11.75	7.48	7.95	3/4"-10 UNC	8	9.65	7.06	1.46	10.67	7.48	1.02	0.75	HPH-04
10"	F10/F12	2.83	1.65	14.25	9.29	9.76	7/8"-9 UNC	12	11.34	8.23	1.46	12.76	9.29	1.18	0.87	HPH-05
12"	F12	3.27	1.85	17.00	11.11	11.65	7/8"-9 UNC	12	12.99	9.84	1.89	15.00	11.08	1.42	1.06	HPH-06

850 (Class 150) Wafer 2" - 16" Dimensions

Rev B

Long Stem for Lever Handle (2" - 6" Sizes)

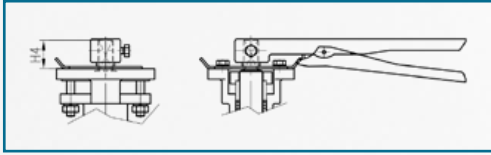

Alternative Mounting (14" - 16" Sizes)

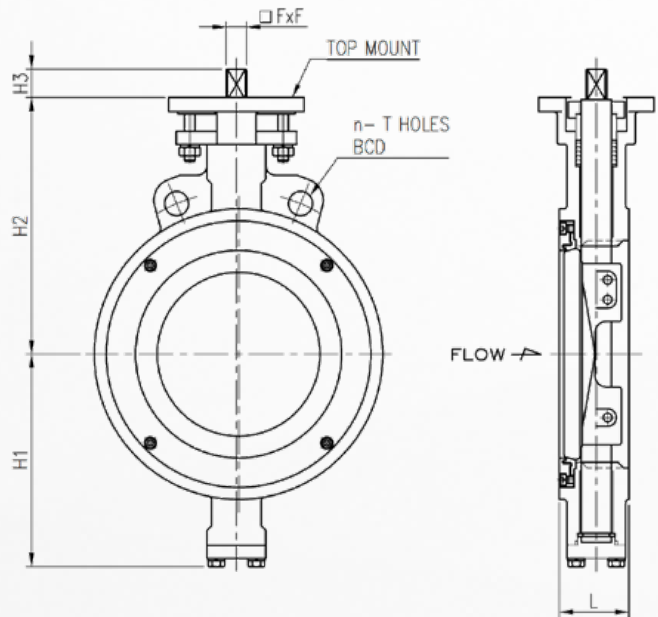
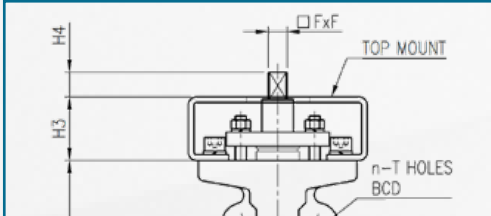

850 (Class 150) Wafer 18" - 24" Dimensions

Rev B

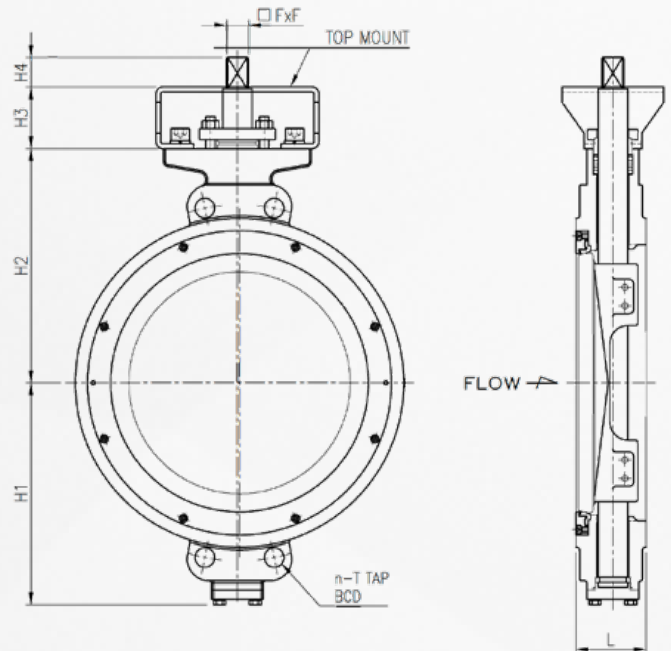

850 Series Rev B | Class 150 Wafer (Units in Inches)

Size	L	n	ØBCD	ØT	H1	H2	H3	H4	□FxF	ISO Mount	Weight (lbs)	Handle Size
2"	1.69	2	4.75	0.75	3.78	4.92	0.51	1.38	0.43	F07	8.6	HPH-02
2.5"	1.81	2	5.50	0.75	4.02	5.87	0.51	1.38	0.43	F07	10.8	HPH-02
3"	1.89	2	6.00	0.75	4.61	6.30	0.51	1.38	0.43	F07	13.6	HPH-02
4"	2.13	2	7.50	0.75	5.04	7.01	0.71	1.38	0.55	F07	18.7	HPH-03
5"	2.24	2	8.50	0.87	5.75	7.60	0.71	1.38	0.55	F07	29.7	HPH-03
6"	2.24	2	9.50	0.87	6.14	8.07	0.87	1.38	0.55	F10	32.3	HPH-04
8"	2.52	2	11.75	0.87	7.68	9.25	1.02	n/a	0.75	F10	53.5	HPH-05
10"	2.80	2	14.25	1.00	8.66	11.02	1.26	n/a	0.87	F12	81.0	HPH-06
12"	3.19	2	17.00	1.00	10.43	12.20	1.38	n/a	1.06	F12	127.8	n/a
14"	3.62	2	18.75	1.13	11.42	12.40	3.54	1.38	1.06	F12, F14	143.7	n/a
16"	4.02	2	21.25	1.13	12.95	13.78	3.54	1.38	1.06	F14, F16	203.7	n/a
18"	4.49	4	22.75	1-1/8" 8UN	14.21	14.96	3.94	1.89	1.42	F14, F16	304.7	n/a
20"	5.00	4	25.00	1-1/8" 8UN	15.75	16.54	4.33	1.89	1.42	F14, F16	386.8	n/a
24"	6.06	4	29.50	1-1/4" 8UN	18.46	18.90	4.33	1.97	1.81	F14, F16	592.7	n/a



851 (Class 150) Lug 2" - 12" Dimensions

Rev B

Long Stem for Lever Handle (2" - 6" Sizes)

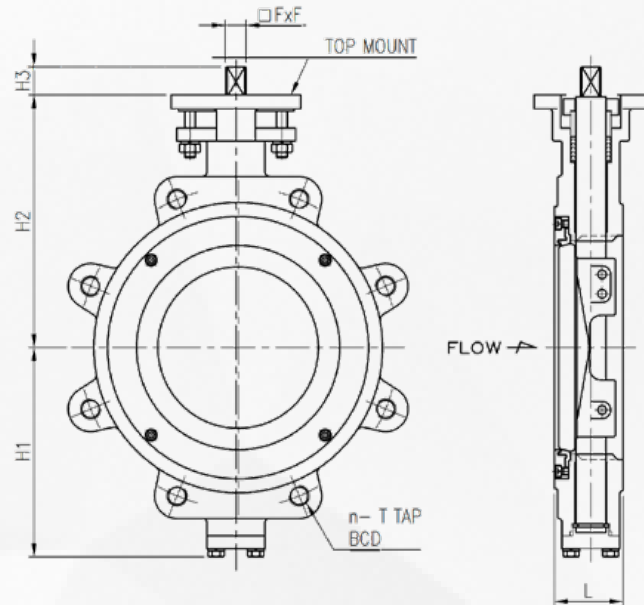
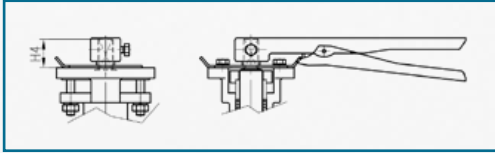

851 (Class 150) Lug 14" - 24" Dimensions

Rev B

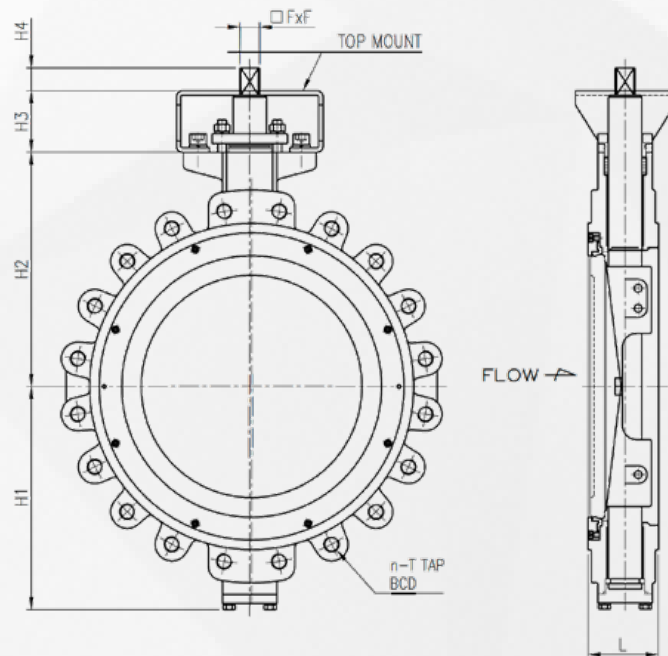

851 Series Rev B | Class 150 Lug (Units in Inches)

Size	L	n	ØBCD	ØT	H1	H2	H3	H4	□FxF	Top Mount	Weight (lbs)	Handle Size
2"	1.69	4	4.75	5/8" UNC	3.78	4.92	0.51	1.38	0.43	F07	13.4	HPH-02
2.5"	1.81	4	5.50	5/8" UNC	4.02	5.87	0.51	1.38	0.43	F07	15.4	HPH-02
3"	1.89	4	6.00	5/8" UNC	4.61	6.30	0.51	1.38	0.43	F07	18.0	HPH-02
4"	2.13	8	7.50	5/8" UNC	5.04	7.01	0.71	1.38	0.55	F07	28.6	HPH-03
5"	2.24	8	8.50	3/4" UNC	5.75	7.60	0.71	1.38	0.55	F07	41.1	HPH-03
6"	2.24	8	9.50	3/4" UNC	6.14	8.07	0.87	1.38	0.55	F10	51.5	HPH-04
8"	2.52	8	11.75	3/4" UNC	7.68	9.25	1.02	n/a	0.75	F10	69.3	HPH-05
10"	2.80	12	14.25	7/8" UNC	8.66	11.02	1.26	n/a	0.87	F12	114.2	HPH-06
12"	3.19	12	17.00	7/8" UNC	10.43	12.20	1.38	n/a	1.06	F12	177.1	n/a
14"	3.62	12	18.75	1" UNC	11.42	12.40	3.54	1.38	1.06	F12, F14	225.1	n/a
16"	4.02	16	21.25	1" UNC	12.95	13.78	3.54	1.38	1.06	F14, F16	308.0	n/a
18"	4.49	16	22.75	1-1/8" 8UN	14.21	14.96	3.94	1.89	1.42	F14, F16	464.9	n/a
20"	5.00	20	25.00	1-1/8" 8UN	15.75	16.54	4.33	1.89	1.42	F14, F16	564.1	n/a
24"	6.06	20	29.50	1-1/4" 8UN	18.46	18.90	4.33	1.97	1.81	F14, F16	878.7	n/a

853 (Class 150) Flanged 3" - 12" Dimensions

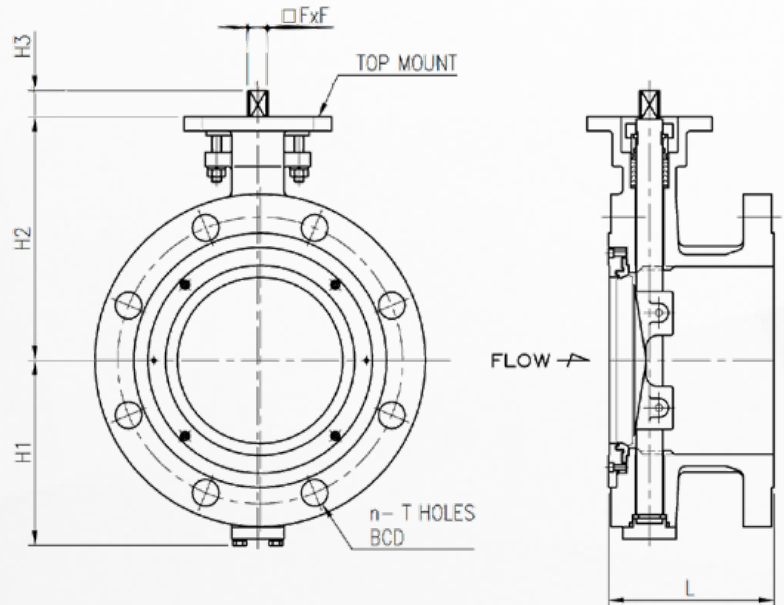

853 (Class 150) Flanged 14" - 24" Dimensions

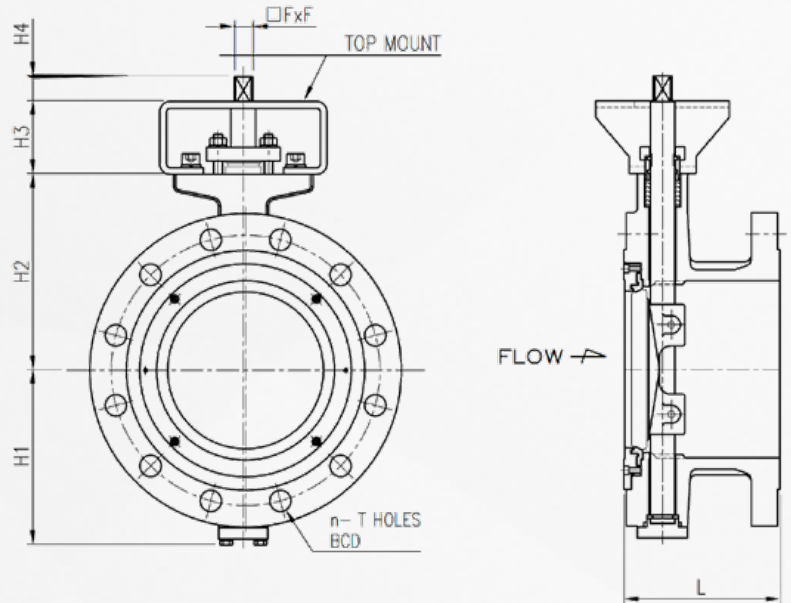

853 Series | Class 150 Flanged (Units in Inches)

Size	L	n	ØBCD	ØT	H1	H2	H3	H4	□FxF	Top Mount	Weight (lbs)
3"	4.49	4	6.00	0.75	4.61	6.30	0.51	n/a	0.43	F07	21.6
4"	5.00	8	7.50	0.75	5.04	7.01	0.71	n/a	0.55	F07	33.0
5"	5.51	8	8.50	0.87	5.75	7.60	0.71	n/a	0.55	F07	49.5
6"	5.51	8	9.50	0.87	6.14	8.07	0.87	n/a	0.55	F10	60.1
8"	5.98	8	11.75	0.87	7.68	9.25	1.02	n/a	0.75	F10	81.4
10"	6.50	12	14.25	1.00	8.66	11.02	1.26	n/a	0.87	F12	139.7
12"	7.01	12	17.00	1.00	10.43	12.20	1.38	n/a	1.06	F12	216.0
14"	7.52	12	18.75	1.12	11.42	12.40	3.54	1.38	1.06	F12, F14	267.3
16"	8.50	16	21.25	1.12	12.95	13.78	3.54	1.38	1.06	F14, F16	365.2
18"	8.74	16	22.75	1.25	14.21	14.96	3.94	1.89	1.42	F14, F16	552.6
20"	9.02	20	25.00	1.25	15.75	16.54	4.33	1.89	1.42	F14, F16	672.1
24"	10.51	20	29.50	1.38	18.46	18.90	4.33	1.97	1.81	F14, F16	1056.0



860 (Class 300) Wafer 2" - 8" Dimensions

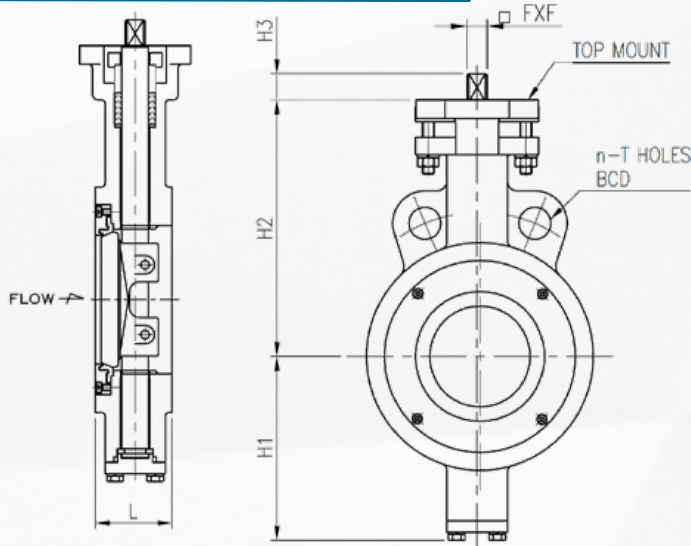

Alternative Design for 6" - 8" Sizes

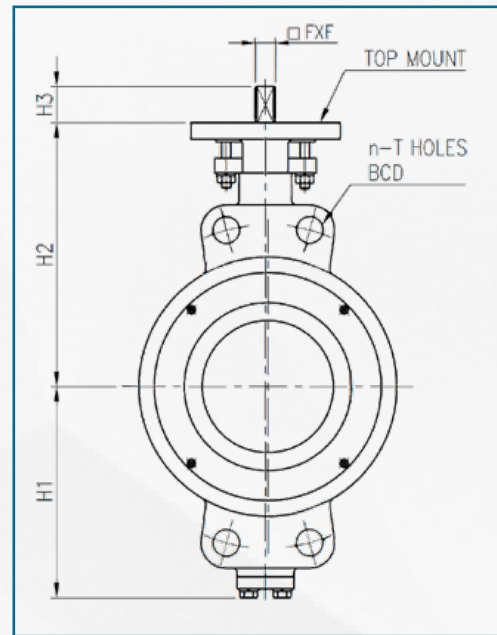

860 (Class 300) Wafer 10" - 24" Dimensions

Alternative Mounting (10" - 12" Sizes)

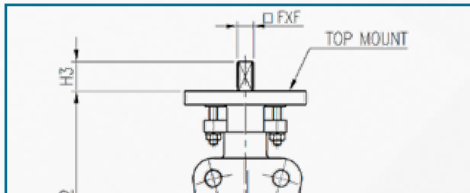

Alternative Mounting (24" Size)

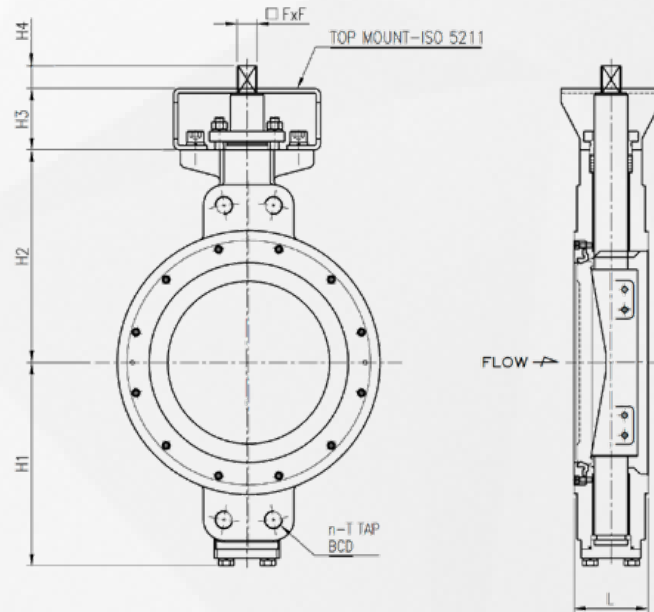
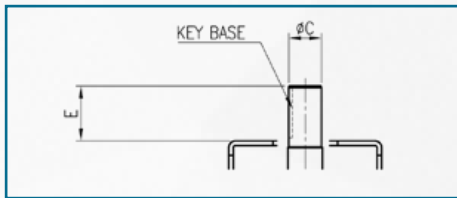

860 Series | Class 300 Wafer (Units in Inches)

Size	L	n	ØBCD	ØT	H1	H2	H3	H4	□FxF	E	C	Key Base	Top Mount	Weight (lbs)
2"	1.69	2	5.00	0.75	3.78	4.92	0.51	n/a	0.43	n/a	n/a	n/a	F07	12.5
2.5"	1.89	2	5.87	0.87	4.02	5.87	0.51	n/a	0.43	n/a	n/a	n/a	F07	15.6
3"	1.89	2	6.63	0.87	4.61	6.30	0.51	n/a	0.43	n/a	n/a	n/a	F07	20.9
4"	2.13	2	7.87	0.87	5.04	7.01	0.71	n/a	0.55	n/a	n/a	n/a	F07	29.0
5"	2.24	2	9.25	0.87	5.75	7.60	0.71	n/a	0.55	n/a	n/a	n/a	F07	43.6
6"	2.32	4	10.63	0.87	6.93	8.66	0.87	n/a	0.67	n/a	n/a	n/a	F10	49.5
8"	2.87	4	13.00	1.00	8.46	10.24	1.26	n/a	0.87	n/a	n/a	n/a	F12	81.4
10"	3.27	4	15.25	1" UNC	10.59	11.42	1.38	n/a	0.87	n/a	n/a	n/a	F12	125.2
12"	3.62	4	17.75	1-1/8" 8UN	11.61	12.80	1.38	n/a	1.06	n/a	n/a	n/a	F12	167.4
14"	4.61	4	20.25	1-1/8" 8UN	12.80	13.98	3.54	1.89	1.42	n/a	n/a	n/a	F14, F16	218.9
16"	5.24	4	22.50	1-1/4" 8UN	14.37	15.43	3.54	1.89	1.42	n/a	n/a	n/a	F14, F16	360.1
18"	5.87	4	24.75	1-1/4" 8UN	16.14	16.46	4.33	1.89	1.42	n/a	n/a	n/a	F14, F16	447.9
20"	6.26	4	27.00	1-1/4" 8UN	17.72	18.70	4.92	1.97	1.81	n/a	n/a	n/a	F25	559.7
24"	7.13	4	32.00	1-1/2" 8UN	20.55	20.87	4.92	n/a	n/a	3.94	Ø2.95	0.79 x 0.47	F25	877.6

861 (Class 300) Lug 2" - 12" Dimensions

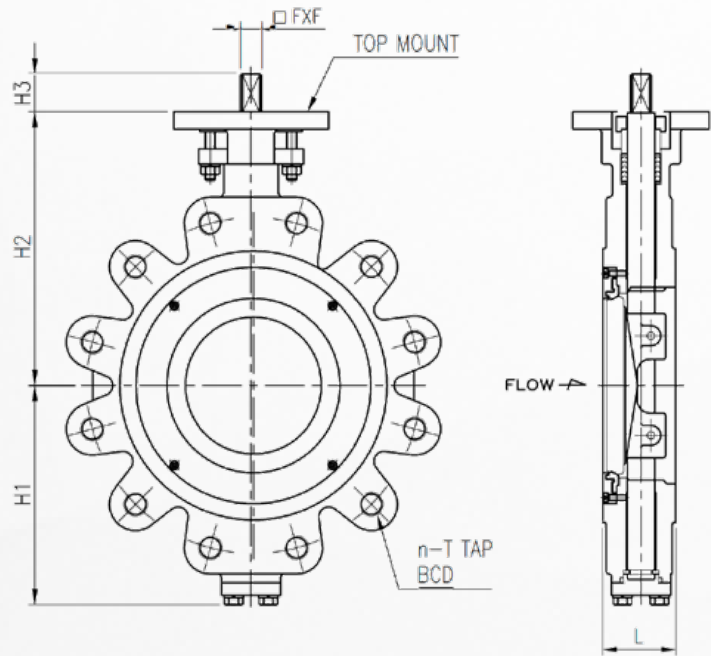

861 (Class 300) Lug 14" - 24" Dimensions

Alternative Mounting (24" Size)

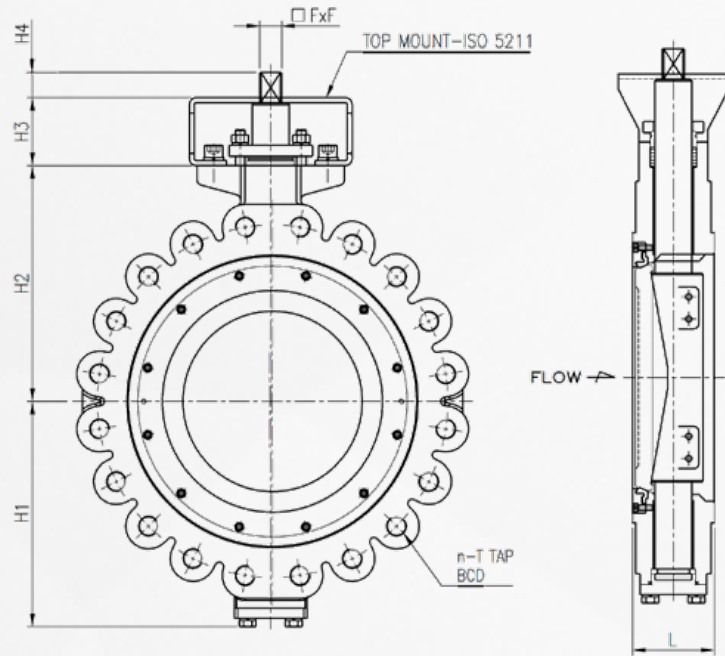
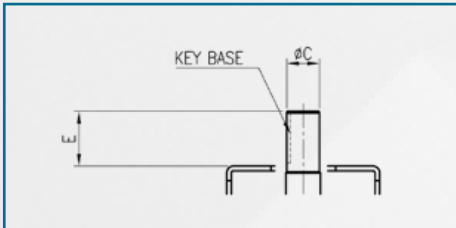

861 Series | Class 300 Lug (Units in Inches)

Size	L	n	ØBCD	ØT	H1	H2	H3	H4	□FxF	E	C	Key Base	Top Mount	Weight (lbs)
2"	1.69	8	5.00	5/8" UNC	3.78	4.92	0.51	n/a	0.43	n/a	n/a	n/a	F07	18.3
2.5"	1.89	8	5.88	3/4" UNC	4.02	5.87	0.51	n/a	0.43	n/a	n/a	n/a	F07	22.7
3"	1.89	8	6.63	3/4" UNC	4.61	6.30	0.51	n/a	0.43	n/a	n/a	n/a	F07	24.6
4"	2.13	8	7.87	3/4" UNC	5.04	7.01	0.71	n/a	0.55	n/a	n/a	n/a	F07	42.2
5"	2.24	8	9.25	3/4" UNC	5.75	7.60	0.71	n/a	0.55	n/a	n/a	n/a	F07	60.7
6"	2.32	12	10.63	3/4" UNC	6.93	8.66	0.87	n/a	0.67	n/a	n/a	n/a	F10	70.8
8"	2.87	12	13.00	7/8" UNC	8.46	10.24	1.26	n/a	0.87	n/a	n/a	n/a	F12	118.4
10"	3.27	16	15.25	1" UNC	10.59	11.42	1.38	n/a	0.87	n/a	n/a	n/a	F12	168.7
12"	3.62	16	17.75	1 1/8" 8UN	11.61	12.80	1.38	n/a	1.06	n/a	n/a	n/a	F12	261.8
14"	4.61	20	20.25	1 1/8" 8UN	12.80	13.98	3.54	1.89	1.42	n/a	n/a	n/a	F14, F16	464.9
16"	5.24	20	22.50	1 1/4" 8UN	14.37	15.43	3.54	1.89	1.42	n/a	n/a	n/a	F14, F16	563.4
18"	5.87	24	24.75	1 1/4" 8UN	16.14	16.46	4.33	1.89	1.42	n/a	n/a	n/a	F14, F16	708.2
20"	6.26	24	27.00	1 1/4" 8UN	17.72	18.70	4.92	1.97	1.81	n/a	n/a	n/a	F25	939.6
24"	7.13	24	32.00	1 1/2" 8UN	20.55	20.87	4.92	n/a	n/a	3.94	Ø2.95	0.79 x 0.47	F25	1335.2



863 (Class 300) Flanged 3" - 12" Dimensions

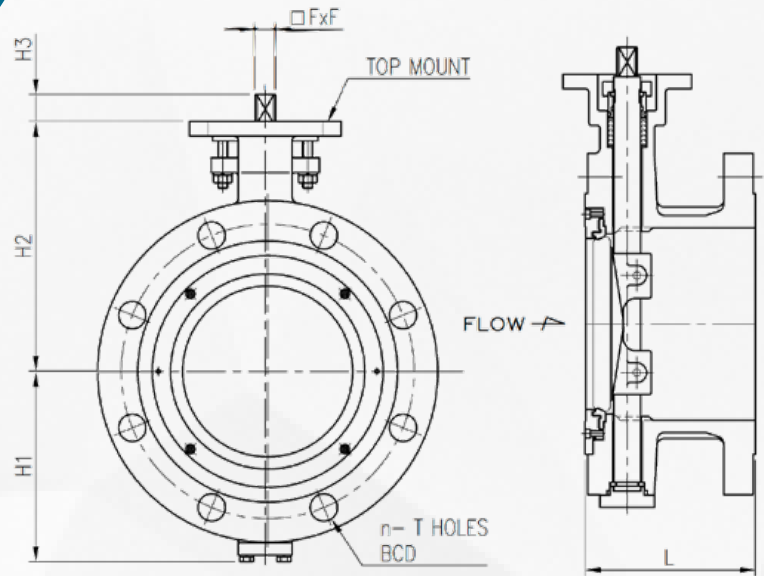

863 (Class 300) Flanged 14" - 24" Dimensions

Alternative Mounting (24" Size)

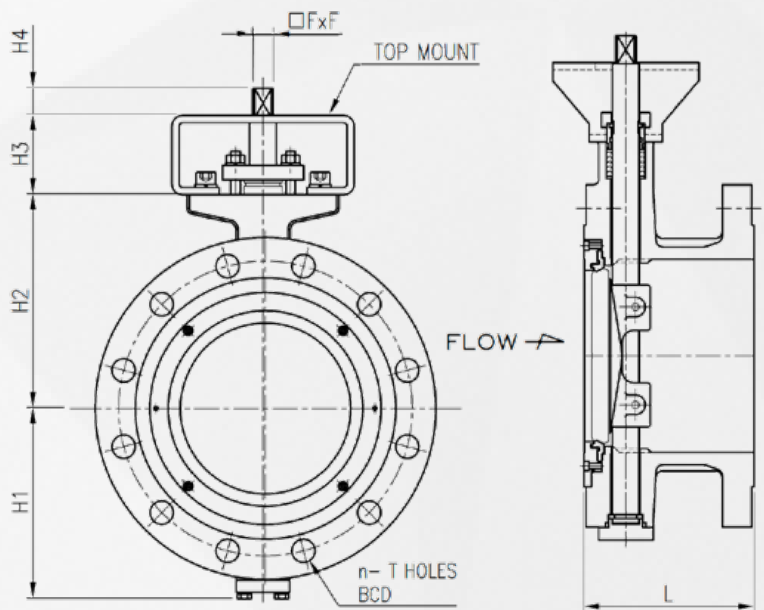
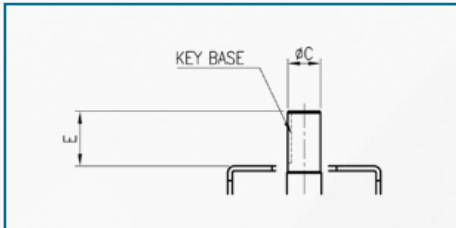

863 Series | Class 300 Flanged (Units in Inches)

Size	L	n	ØBCD	ØT	H1	H2	H3	H4	□FxF	E	C	Key Base	Top Mount	Weight (lbs)
3"	7.09	8	6.63	0.87	4.61	6.30	0.51	n/a	0.43	n/a	n/a	n/a	F07	29.7
4"	7.48	8	7.87	0.87	5.04	7.01	0.71	n/a	0.55	n/a	n/a	n/a	F07	50.6
5"	8.27	8	9.25	0.87	5.75	7.60	0.71	n/a	0.55	n/a	n/a	n/a	F07	77.0
6"	8.27	12	10.63	0.87	6.93	8.66	0.87	n/a	0.67	n/a	n/a	n/a	F10	84.7
8"	9.06	12	13.00	1.00	8.46	10.24	1.26	n/a	0.87	n/a	n/a	n/a	F12	141.9
10"	9.84	16	15.25	1.12	10.59	11.42	1.38	n/a	0.87	n/a	n/a	n/a	F12	205.0
12"	10.63	16	17.75	1.25	11.61	12.80	1.38	n/a	1.06	n/a	n/a	n/a	F12	319.0
14"	11.42	20	20.25	1.25	12.80	13.98	3.54	1.89	1.42	n/a	n/a	n/a	F14, F16	561.2
16"	12.20	20	22.50	1.38	14.37	15.43	3.54	1.89	1.42	n/a	n/a	n/a	F14, F16	687.7
18"	12.99	24	24.75	1.38	16.14	16.46	4.33	1.89	1.42	n/a	n/a	n/a	F14, F16	862.4
20"	13.78	24	27.00	1.38	17.72	18.70	4.92	1.97	1.81	n/a	n/a	n/a	F25	1129.0
24"	15.35	24	32.00	1.62	20.55	20.87	4.92	n/a	n/a	3.94	Ø2.95	0.79 x 0.47	F25	1608.2

871 (Class 600) Lug 3" - 8" Dimensions

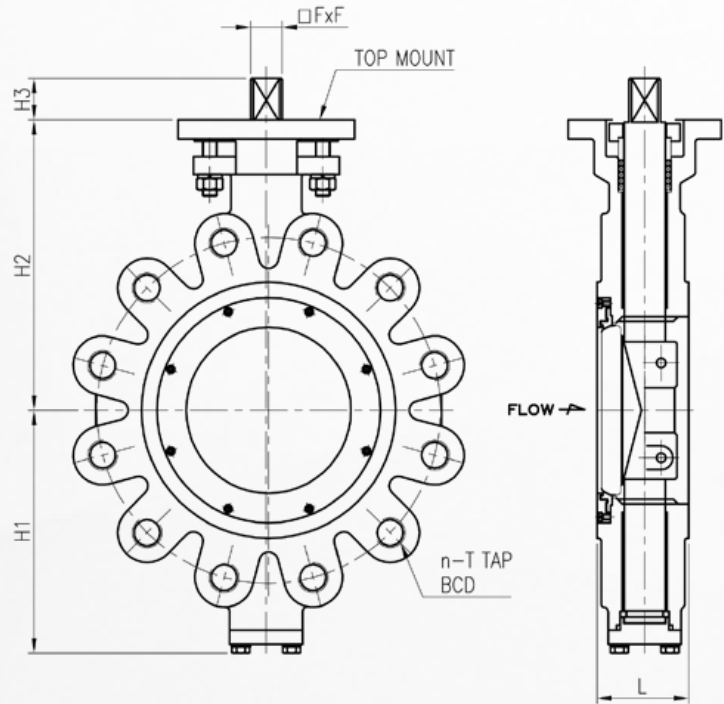

871 (Class 600) Lug 10" - 24" Dimensions

Alternative Mounting (12" - 24" Sizes)

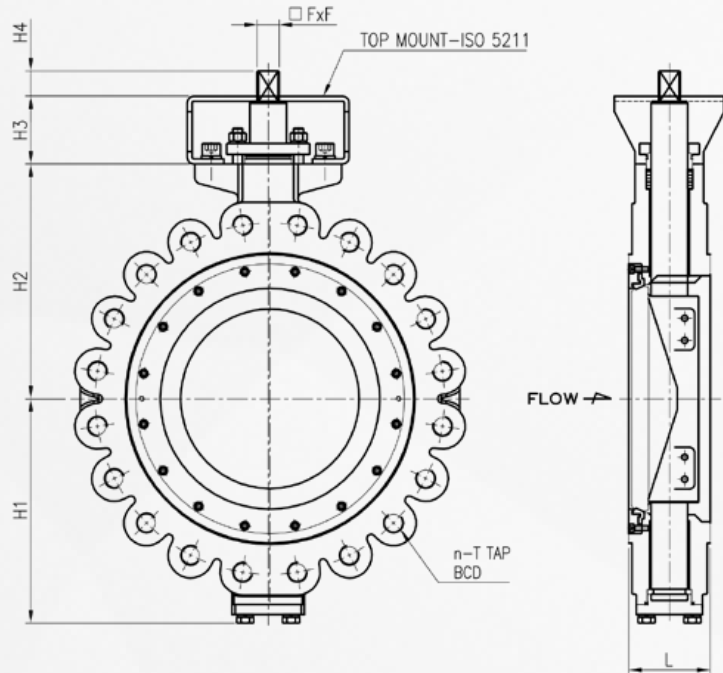
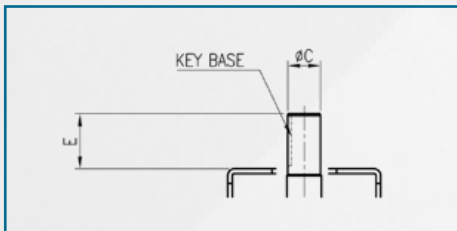

871 Series | Class 600 Lug (Units in Inches)

Size	L	n	ØBCD	ØT	H1	H2	H3	H4	□Fx F	E	C	Key Base	Top Mount	Weight (lbs)
3"	2.13	8	6.63	3/4" UNC	4.92	6.57	0.71	n/a	0.55	n/a	n/a	n/a	F10	33.7
4"	2.52	8	8.50	7/8" UNC	5.71	7.68	0.71	n/a	0.55	n/a	n/a	n/a	F10	56.1
6"	3.07	12	11.50	1" UNC	8.07	9.65	1.38	n/a	1.06	n/a	n/a	n/a	F12	84.7
8"	4.02	12	13.75	1-1/8" 8UN	9.45	12.60	1.42	n/a	1.06	n/a	n/a	n/a	F14	92.4
10"	4.61	16	17.00	1-1/4" 8UN	11.02	11.42	3.54	1.42	1.06	n/a	n/a	n/a	F14+F16	225.5
12"	5.51	20	19.25	1-1/4" 8UN	12.72	13.98	3.74	n/a	n/a	3.94	Ø2.36	0.71 x 0.43	F14+F16	378.4
14"	6.10	20	20.75	1-3/8" 8UN	14.57	14.96	3.74	n/a	n/a	4.02	Ø2.56	0.71 x 0.43	F14+F16	671.4
16"	7.01	20	23.75	1-1/2" 8UN	15.94	17.13	3.94	n/a	n/a	4.13	Ø2.95	0.79 x 0.47	F14+F16	819.5
18"	7.87	20	25.75	1-5/8" 8UN	17.72	18.50	4.33	n/a	n/a	4.13	Ø2.95	0.79 x 0.47	F25	1034.0
20"	8.50	24	28.50	1-5/8" 8UN	19.29	19.69	4.92	n/a	n/a	5.12	Ø3.74	0.98 x 0.55	F25+F30	1353.0
24"	9.13	24	33.00	1-7/8" 8UN	23.03	21.65	5.12	n/a	n/a	5.12	Ø3.74	0.98 x 0.55	F25+F30	1925.0



This page intentionally left blank.

Class 150 Cv Values - Valve Sizing Coefficients (US-GPM/ΔP)

Size (in)		Disc Position								
ANSI	DN	10°	20°	30°	40°	50°	60°	70°	80°	90°
2	50	2	6	16	26	39	55	70	85	95
2.5	65	2	7	19	34	48	65	85	105	120
3	80	3	12	27	48	70	105	145	180	195
4	100	5	25	60	105	145	201	272	350	390
5	125	15	44	83	149	242	366	504	650	695
6	150	17	94	183	285	394	530	684	870	990
8	200	39	181	325	476	690	980	1,389	1,790	2,100
10	250	80	202	454	754	1,185	1,821	2,611	3,541	4,200
12	300	141	280	576	923	1,825	2,671	4,127	5,800	6,300
14	350	150	360	747	1,130	1,909	3,121	4,650	6,700	8,010
16	400	250	432	803	1,422	2,289	3,614	5,251	7,850	9,600
18	450	366	548	1,121	1,869	2,990	4,735	6,800	9,951	11,780
20	500	405	680	1,390	3,040	4,010	6,175	8,795	12,780	15,350
24	600	560	991	2,076	3,803	6,050	9,090	13,302	18,760	21,650

Class 300 Cv Values - Valve Sizing Coefficients (US-GPM/ΔP)

Size (in)		Disc Position								
ANSI	DN	10°	20°	30°	40°	50°	60°	70°	80°	90°
2	50	2	6	15	24	35	49	62	77	87
3	80	3	11	25	42	66	99	132	152	181
4	100	5	24	55	91	132	189	253	329	362
6	150	16	94	162	253	359	483	629	801	920
8	200	37	181	289	430	629	894	1,278	1,648	1,832
10	250	75	202	403	680	1,081	1,662	2,404	3,260	1,667
12	300	136	280	511	830	1,666	2,438	3,800	5,340	5,701
14	350	150	360	588	1,102	1,743	2,848	4,281	6,169	7,175
16	400	239	432	713	1,290	2,090	3,298	4,835	7,228	8,539
18	450	361	548	995	1,682	2,740	4,322	6,261	9,162	10,547
20	500	392	680	1,233	2,720	3,660	5,636	8,098	11,762	13,992
24	600	548	991	1,841	3,420	5,522	8,297	12,248	17,724	19,223
20	500	405	680	1,390	3,040	4,010	6,175	8,795	12,780	15,350
24	600	560	991	2,076	3,803	6,050	9,090	13,302	18,760	21,650

Class 600 Cv Values - Valve Sizing Coefficients (US-GPM/ΔP)

Size (in)		Disc Position								
ANSI	DN	10°	20°	30°	40°	50°	60°	70°	80°	90°
3	80	2	8	19	32	50	75	100	116	138
4	100	4	18	42	69	100	144	192	250	275
6	150	12	71	123	192	273	367	478	609	723
8	200	28	138	220	327	478	679	971	1,252	1,420
10	250	57	154	306	517	822	1,263	1,827	2,478	2,787
12	300	103	213	388	631	1,266	1,853	2,888	4,058	4,333
14	350	114	274	447	838	1,325	2,164	3,254	4,688	5,453
16	400	182	328	542	980	1,588	2,506	3,675	5,493	6,490
18	450	274	416	756	1,278	2,082	3,285	4,758	6,963	8,016
20	500	298	517	937	2,067	2,782	4,283	6,154	8,939	10,634
24	600	416	753	1,399	2,599	4,197	6,306	9,308	13,470	14,609



Class 150 Seating Torques (in-lbs) (Multiply Seating Torques by Seat Adjustment Factor)

Size in	50 ΔP		100 ΔP		150 ΔP		200 ΔP		290 ΔP	
	Wet	Dry	Wet	Dry	Wet	Dry	Wet	Dry	Wet	Dry
2"	226	293	239	311	266	345	292	380	319	414
2-1/2"	252	328	266	345	305	397	332	431	358	466
3"	305	397	319	414	345	449	385	501	412	535
4"	438	570	478	621	504	656	584	759	637	828
5"	518	673	544	708	611	794	783	1,018	929	1,208
6"	690	897	717	932	996	1,294	1,195	1,553	1,460	1,898
8"	1,261	1,640	1,394	1,812	1,739	2,261	2,045	2,658	2,788	3,624
10"	1,660	2,157	1,925	2,503	2,549	3,314	2,868	3,728	4,049	5,264
12"	2,124	2,761	2,854	3,711	3,943	5,126	4,740	6,161	6,744	8,768
14"	3,253	4,228	4,647	6,041	5,841	7,594	7,076	9,199	9,957	12,944
16"	4,049	5,264	5,841	7,594	7,368	9,579	9,824	12,772	14,006	18,208
18"	5,324	6,921	7,607	9,889	9,519	12,375	12,732	16,551	18,241	23,714
20"	7,780	10,114	11,112	14,446	13,887	18,053	18,600	24,180	26,685	34,691
24"	13,303	17,293	16,635	21,625	20,804	27,045	27,867	36,227	39,988	51,984

Class 150 Seat Adjustment Factor

Code	Seat	Multiplier
P, T	PTFE, TFM 1600	1.00
R	RTFE	1.15
M, N, O, 1, 5	Metal	1.45
F, G, H, I	Fire Safe	1.35

Class 300 Seating Torques (in-lbs) (Multiply Seating Torques by Seat Adjustment Factor)

Size in	300 ΔP		400 ΔP		500 ΔP		600 ΔP		725 ΔP	
	Wet	Dry	Wet	Dry	Wet	Dry	Wet	Dry	Wet	Dry
2"	425	552	451	587	478	621	518	673	584	759
2-1/2"	478	621	531	690	597	777	664	863	690	897
3"	584	759	637	828	770	1,001	890	1,156	1,062	1,381
4"	903	1,174	996	1,294	1,208	1,571	1,421	1,847	1,686	2,192
5"	1,142	1,484	1,261	1,640	1,553	2,019	1,832	2,382	2,191	2,848
6"	1,646	2,140	1,978	2,572	2,443	3,176	2,907	3,780	3,478	4,522
8"	3,000	3,901	3,956	5,143	4,912	6,386	5,868	7,628	7,063	9,182
10"	5,005	6,507	6,625	8,612	8,258	10,735	9,877	12,841	11,882	15,447
12"	7,687	9,993	10,183	13,238	12,679	16,482	15,188	19,744	18,295	23,783
14"	13,343	17,345	17,710	23,023	22,065	28,684	26,433	34,363	31,863	41,422
16"	16,808	21,850	22,330	29,030	27,840	36,192	33,363	43,372	40,240	52,312
18"	21,441	27,873	28,477	37,020	35,514	46,168	42,550	55,315	51,325	66,723
20"	29,898	38,867	39,762	51,691	49,613	64,497	59,477	77,320	71,771	93,302
24"	47,369	61,580	63,022	81,928	78,688	102,294	94,340	122,642	113,869	148,030

Class 300 Seat Adjustment Factor

Code	Seat	Multiplier
P, T	PTFE, TFM 1600	1.00
M, N, O, 1, 5	Metal	1.60
F, G, H, I	Fire Safe	1.45

Class 600 Seating Torques (in-lbs) (Multiply Seating Torques by Seat Adjustment Factor)

Size in	600 ΔP		750 ΔP		900 ΔP		1100 ΔP		1450 ΔP	
	Wet	Dry	Wet	Dry	Wet	Dry	Wet	Dry	Wet	Dry
3"	1,089	1,415	1,261	1,640	1,500	1,950	1,779	2,313	2,297	2,986
4"	1,513	1,968	1,806	2,347	2,111	2,744	2,522	3,279	3,757	4,884
6"	3,359	4,367	4,129	5,368	4,899	6,369	5,934	7,715	7,886	10,252
8"	6,399	8,319	7,926	10,304	9,453	12,288	11,497	14,946	15,360	19,969
10"	10,342	13,445	12,851	16,707	15,347	19,951	18,706	24,318	25,092	32,619
12"	17,538	22,799	21,826	28,374	26,127	33,966	31,876	41,439	42,816	55,660
14"	28,345	36,848	35,341	45,943	42,324	55,022	51,684	67,189	69,461	90,299
16"	37,346	48,549	46,559	60,527	55,786	72,522	68,146	88,590	91,605	119,087
18"	46,825	60,872	58,402	75,922	69,978	90,972	85,472	111,113	114,905	149,376
20"	70,337	91,438	87,755	114,082	105,173	136,726	128,513	167,067	172,829	224,677
24"	103,554	134,620	129,230	167,999	154,893	201,360	189,278	246,061	254,570	330,941

Class 600 Seat Adjustment Factor

Code	Seat	Multiplier
T	TFM 1600	1.00
M, N, O, 1, 5	Metal	1.80
F, G, H, I	Fire Safe	1.45

*Note! Torques include safety factor for actuator sizing. Wet torques include 30% safety and assume water service or similar; Dry torques include 50% safety factor and assume Dry Media / Air service or similar.

Class 150 - Pressure vs Temperature Chart

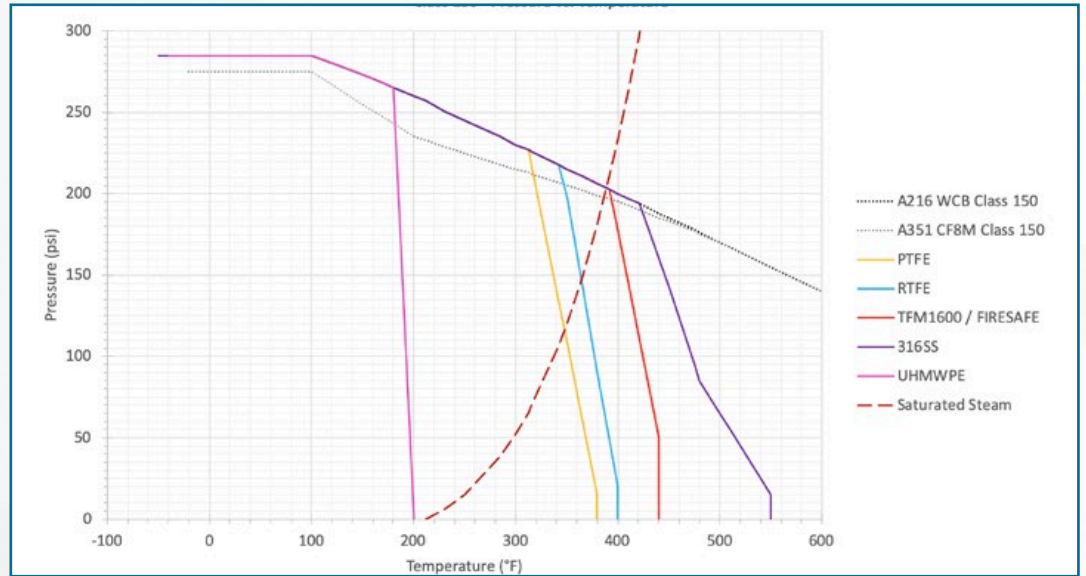

Class 300 - Pressure vs Temperature Chart

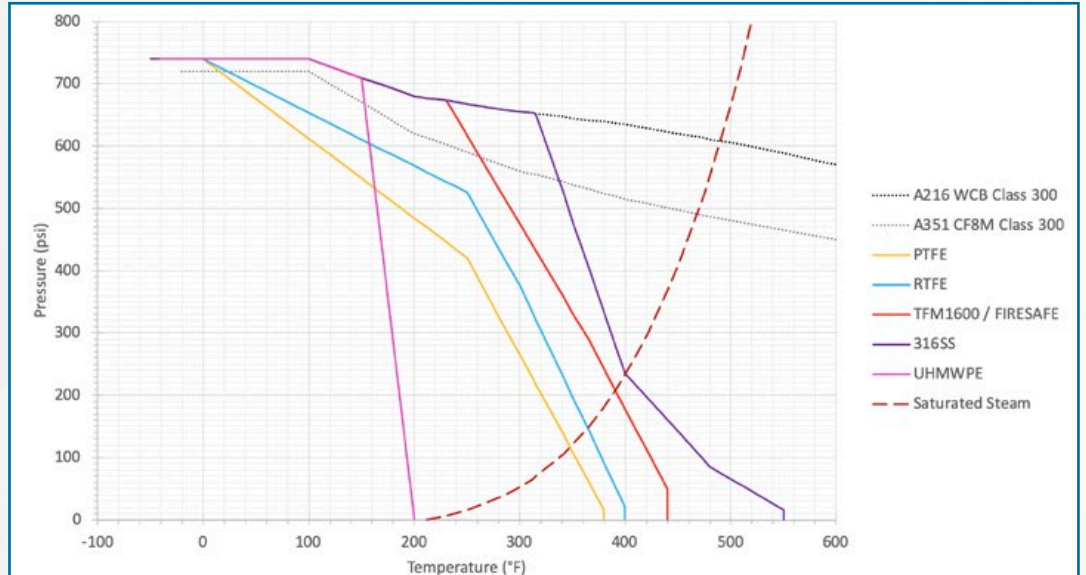

Class 600 - Pressure vs Temperature Chart

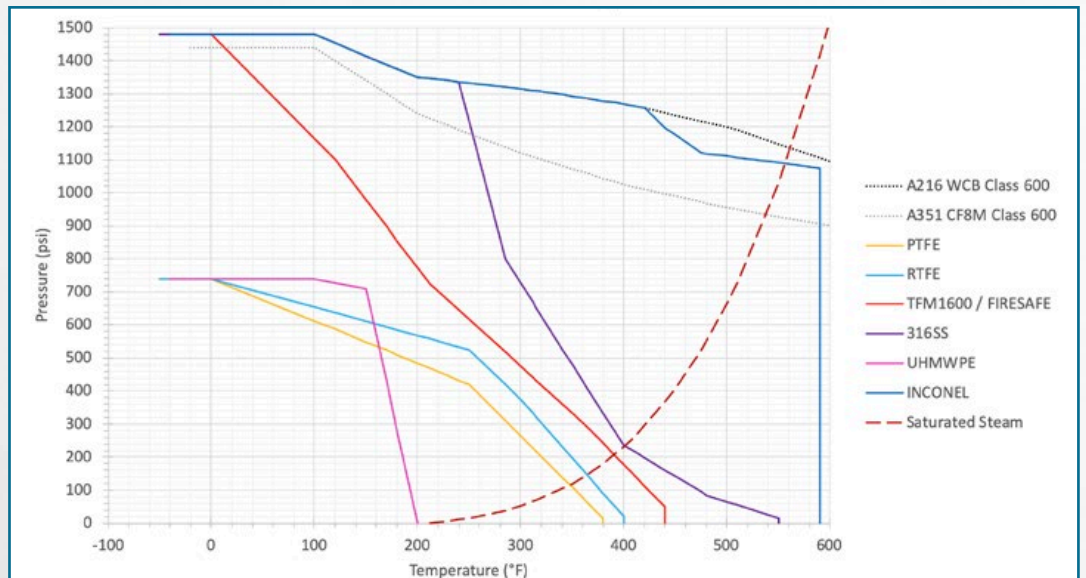

Ordering Guideline

Series 800 Example Part Number, Part Builder, & Crossover Guide

Ex.

A-SIZE	040
--------	-----

 -

B-CODE	850
--------	-----

 -

C-BODY	C
--------	---

D-DISC	S
--------	---

E-STEM	O
--------	---

F-SEAT	P
--------	---

 -

G-OPERATOR	BST
------------	-----

 -

H-SPECIAL	
-----------	--

A-SIZE	B-CODE	C-BODY
020-2" 240-24"	850 - CLASS 150 - ANSI/DIN WAFER	C - ASTM A216 WCB
025-2.5" 280-28"	851 - CLASS 150 - ANSI LUG	S - ASTM A351 CF8M
030-3" 300-30"	852 - CLASS 150 - DIN LUG	B - ALUMINUM BRONZE ASTM B148 C95800
040-4" 320-32"	853 - CLASS 150 - ISO 5752 FLANGED (SHORT)	D - 2205 DUPLEX SS-UNS S32205/F51
050-5" 360-36"	860 - CLASS 300 - ANSI/DIN WAFER	E - 2507 SUPER DUPLEX SS-UNS S32750/F53
060-6" 400-40"	861 - CLASS 300 - ANSI LUG	T - ASTM B367 TITANIUM, GRADE C2
080-8" 420-42"	862 - CLASS 300 - DIN LUG	L - CARBON STEEL ASTM A352 LCB (BODY, DISC)
100-10" 480-48"	863 - CLASS 300 - ISO 5752 FLANGED (SHORT)	OTHER ALLOYS AVAILABLE UPON REQUEST (TITANIUM, INCONEL, HASTELLOY, ETC.)
120-12" 540-52"	871 - CLASS 600 - ANSI LUG	
140-14" 600-56"	872 - CLASS 600 - DIN LUG	
160-16" 600-60"		
180-18" 660-64"		
200-20" 720-72"		

Previous Part # Crossover Guide

D-DISC	E-STEM	OLD PART	NEW PART
S - ASTM A351 CF8M	O - 316-ASTM A274-S31600	750-821	850-CSPR
X - 316 + HARD CHROME PLATING	P - 17-4PH-ASTM	750-822	850-CSOR
B - ASTM B148 C95800 ALUMINUM BRONZE	A564-TYPE630/17-4PH	750-823	850-CSPP
D - 2205 DUPLEX SS-UNS S32205/F51	D - DUPLEX SS F51/2205	750-824	850-CSOP
E - 2507 SUPER DUPLEX SS-UNS S32750/F53	S32205/F51/F60	750-825	850-CSPT
T - ASTM B367 TITANIUM, GRADE C2	E - SUPER DUPLEX SS F53/2507	750-826	850-CSOT
OTHER ALLOYS AVAILABLE UPON REQUEST (TITANIUM, INCONEL, HASTELLOY, ETC.)	SS-UNS S32750	750-827	850-CSPF
	K - N05500 MONEL K500	750-828	850-CSOF
	OTHER ALLOYS AVAILABLE UPON REQUEST (TITANIUM, INCONEL, HASTELLOY, ETC.)	751-821	851-CSPR
		751-822	851-CSOR
		751-823	851-CSPP
		751-824	851-CSOP
		751-825	851-CSPT
		751-826	851-CSOT
		751-827	851-CSPF
		751-828	851-CSOF
		850-821	850-SSPR
		850-822	850-SSOR
		850-823	850-SSPP
		850-824	850-SSOP
		850-825	850-SSPT
		850-826	850-SSOT
		850-827	850-SSPF
		850-828	850-SSOF
		851-821	851-SSPR
		851-822	851-SSOR
		851-823	851-SSPP
		851-824	851-SSOP
		851-825	851-SSPT
		851-826	851-SSOT
		851-827	851-SSPF
		851-828	851-SSOF

*Note: 800 Series Part Numbers have been updated with the new product expansion for consistency across series. The three digit trim codes have been updated with four character trim codes that represent the materials of construction.

F-SEAT
P - PTFE
R - RTFE
T - TFM 1600
U - UHMWPE
M - METAL SEATED 316 SS + HCR
N - METAL SEATED INCONEL 600
F - RTFE + 316 SS FIRE SAFE
G - RTFE + INCONEL 600 FIRE SAFE
H - TFM 1600 + 316 SS FIRE SAFE
I - TFM 1600 + INCONEL 600 FIRE SAFE

G-OPERATOR
BST - BARE STEM
HND - LEVER HANDLE
GOP - GEAR OPERATOR
Cxx - CHAINWHEEL OPERATOR
("xx" = LENGTH)

H-SPECIAL
BLANK - (NONE)
O2 - CLEANED AND BAGGED FOR OXYGEN SERVICE
SF - SILICONE FREE CLEANED
VS - VACUUM SERVICE



*QR Code
for Website

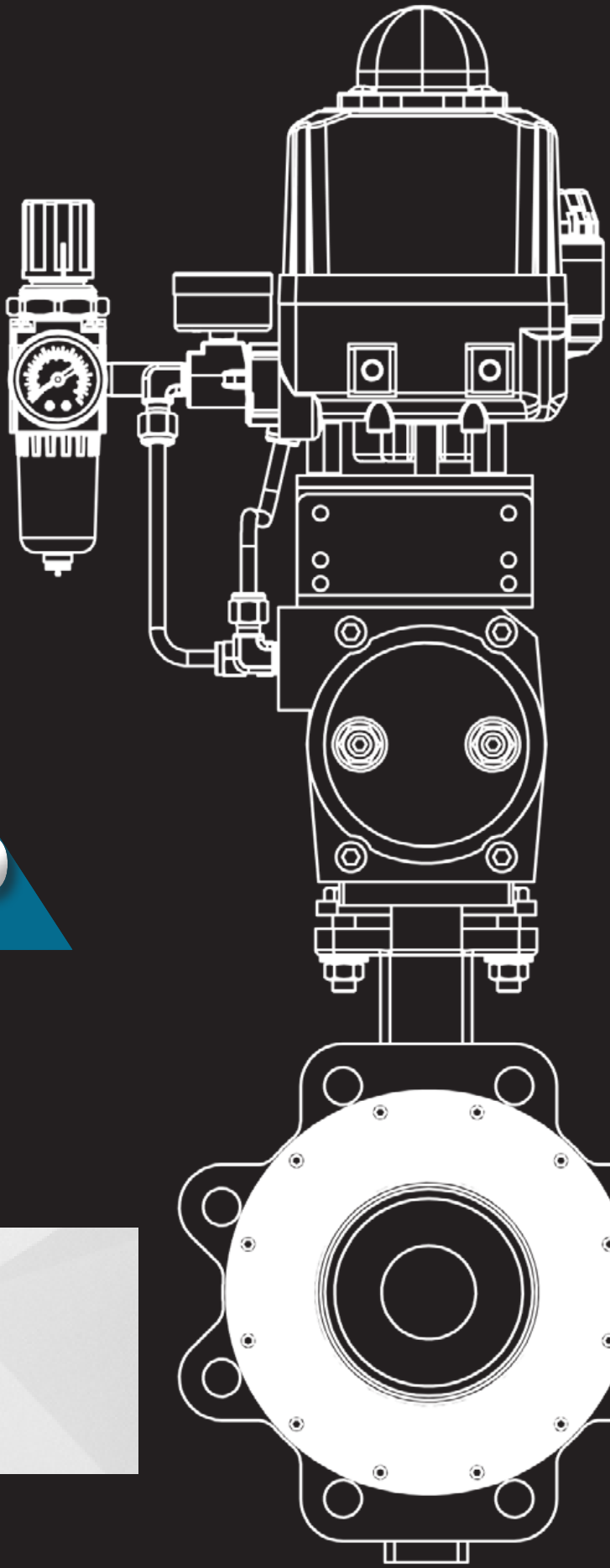

THE BRAND
BY WHICH
ALL OTHERS ARE
MEASURED

