

Dripmaster EDD-4SH

U.S. Patent No. 5,996,739 & other countries

User Guide

Document filename: Dripmaster_EDD-4SH_User Guide_22Dec15.doc

Important notice: Hoffmann & Hoffmann reserves the right to change this document without further notice due to design improvements, functional modifications or quality/reliability amendments.

CAUTION!

ENSURE THE FREE FLOW OF OIL

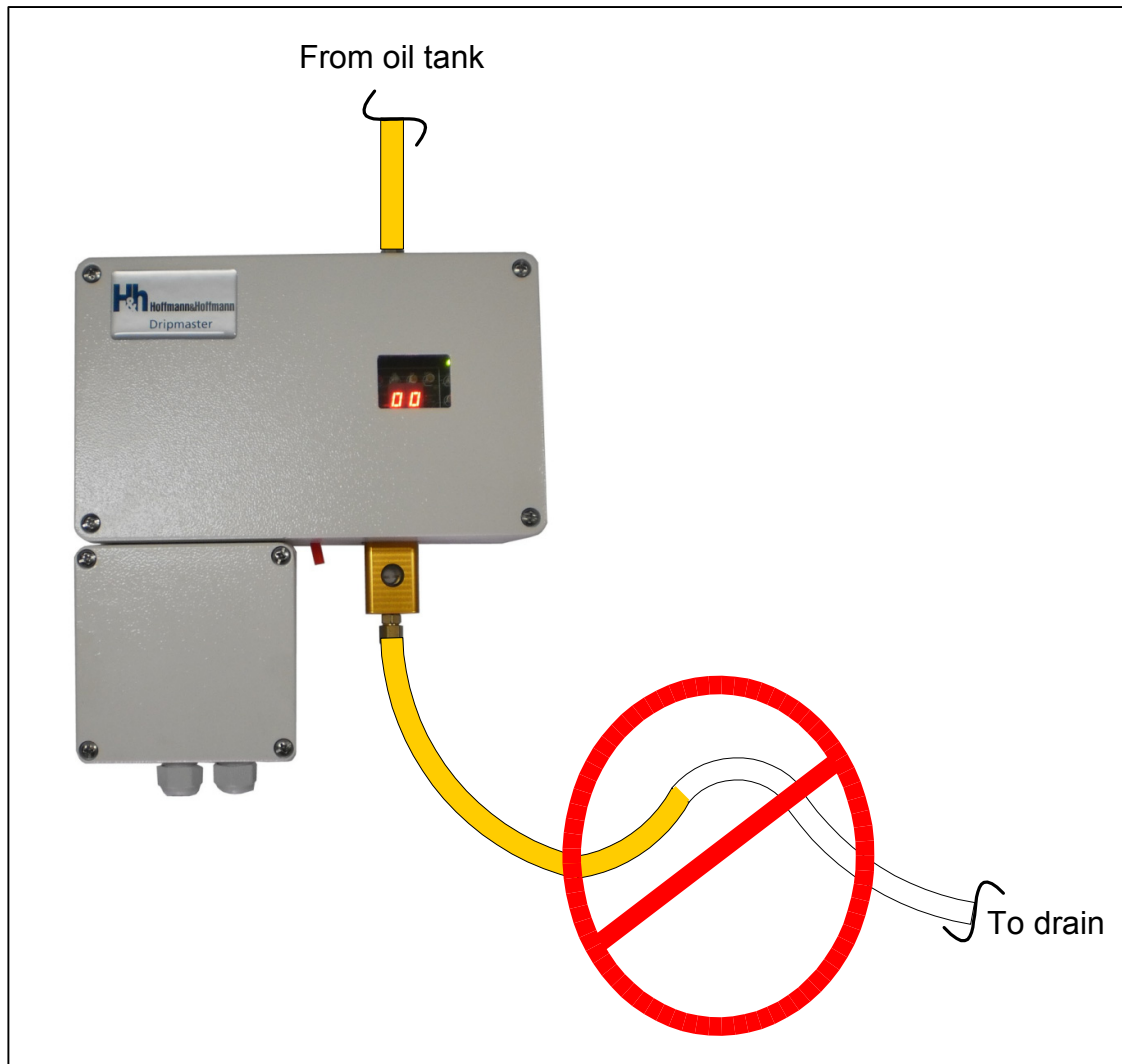

Entire drain tube must face downward to prevent oil backup.

Contents

Section 1: Introduction	5
Overview	5
Section 2: Installation	6
General.....	6
Well Site Requirements.....	6
Installation Kit.....	8
Mounting the Dripmaster.....	8
Wiring the Power and Control Cables.....	9
Setting the Drip Rate.....	12
Section 3: Operation	13
Controls and Indicators	13
Resetting the Dripmaster	16
Automatic Control.....	16
Setting Normal (pump on) Mode Drip Rates	16
Pre-lube (pump off) Mode.....	19
Manual Control.....	19
Section 4: Theory of Operation	20
General.....	20
Search Feature	22
Push-Down and Push-up Features.....	23
Section 5: Maintenance and Troubleshooting.....	24
Section 6: Specifications	26
Overall Dimensions	27
Section 7: Dripmaster Service Policy	28
Installation	28
Repair procedure	28
PC Board Replacement in the Field.....	29
Product within the Warranty Period	30
Product Out-of-Warranty Period	30
Return Instructions	30
Terms & Conditions on reverse	31

List of Figures

Figure 1: Dripmaster EDD-4SH	5
Figure 2: Installation requirements	7
Figure 3: Dripmaster—rear view showing mounting centers.....	8
Figure 4: Connection box – cable routing.....	9
Figure 5: Connection box – electrical terminals: 115 VAC unit shown.....	9
Figure 6: Connection box PCB – wiring diagram.....	10
Figure 7: Dripmaster control panel	13
Figure 8: Dripmaster EDD-4SH Needle Valve Assembly	19
Figure 9: Common Needle Valve compared to Dripmaster.....	20
Figure 10: Dripmaster functional diagram	21
Figure 11: Dripmaster EDD-4SH Needle Valve Assembly	22
Figure 12: Dripmaster dimensions.....	27
Figure 13: Dripmaster PC board replacement.....	29

List of Tables

Table 1: Connection box—power and control lines	11
Table 2: Pump On/Off conditions	12
Table 3: Control panel—controls and indicators.....	13
Table 4: Routine Maintenance.....	24
Table 5: Troubleshooting	24
Table 6: Dripmaster EDD-4SH specifications.....	26
Table 7: Oil volume fed to line shaft	26

Section 1: Introduction

Overview

The Dripmaster is an active vertical line-shaft lubrication control and monitoring device. It automatically stabilizes the oil drip rate so as to comply with pump manufacturer's requirements.



Figure 1: Dripmaster EDD-4SH

Constant drip rate is maintained regardless of ambient temperature or hydrostatic pressure in the feeding oil tank. This is achieved by monitoring and controlling the drip rate 55 times per hour.

There are two modes of operation:

- **Normal (pump on) mode**—when the well pump is operational
- **Pre-lube (pump off) mode**—ensures that the line-shaft is lubricated prior to turning on the well pump.

Automatic switching between the Normal (pump on) and Pre-lube (pump off) modes is achieved by remotely sending a control signal to the Dripmaster.

The SCADA interface provides:

- Accurate oil consumption data (drip rate count)
- Total lack of oil warning
- Automatic pump shutdown

A built-in manual mechanism ensures oil flow even in the remote possibility of unit malfunction.

Section 2: Installation

General

The Dripmaster installation procedure is simple and does not require any special tools, but requires site preparation.

Well Site Requirements

- Line power (115 VAC or 220 VAC), or 24 V DC/AC must be available at the well pump.
- An eight-wire control cable (containing wires not smaller than 22 AWG) needs to be laid between the well pump and the local PLC enclosure.
- A sturdy, vertical pole with a welded metal plate should be in close proximity to the well pump.

Note: For large oil tanks (35 to 50 gallons), mount the Dripmaster to the oil tank stand.

Important: The relative spacing between the oil tank, the Dripmaster, and the line-shaft inlet should be according to Figure 2. In order to maintain minimal oil pressure on the needle valve (especially when the oil tank is almost empty), the oil inlet should be in the range of 10 to 14 inches below the oil tank.

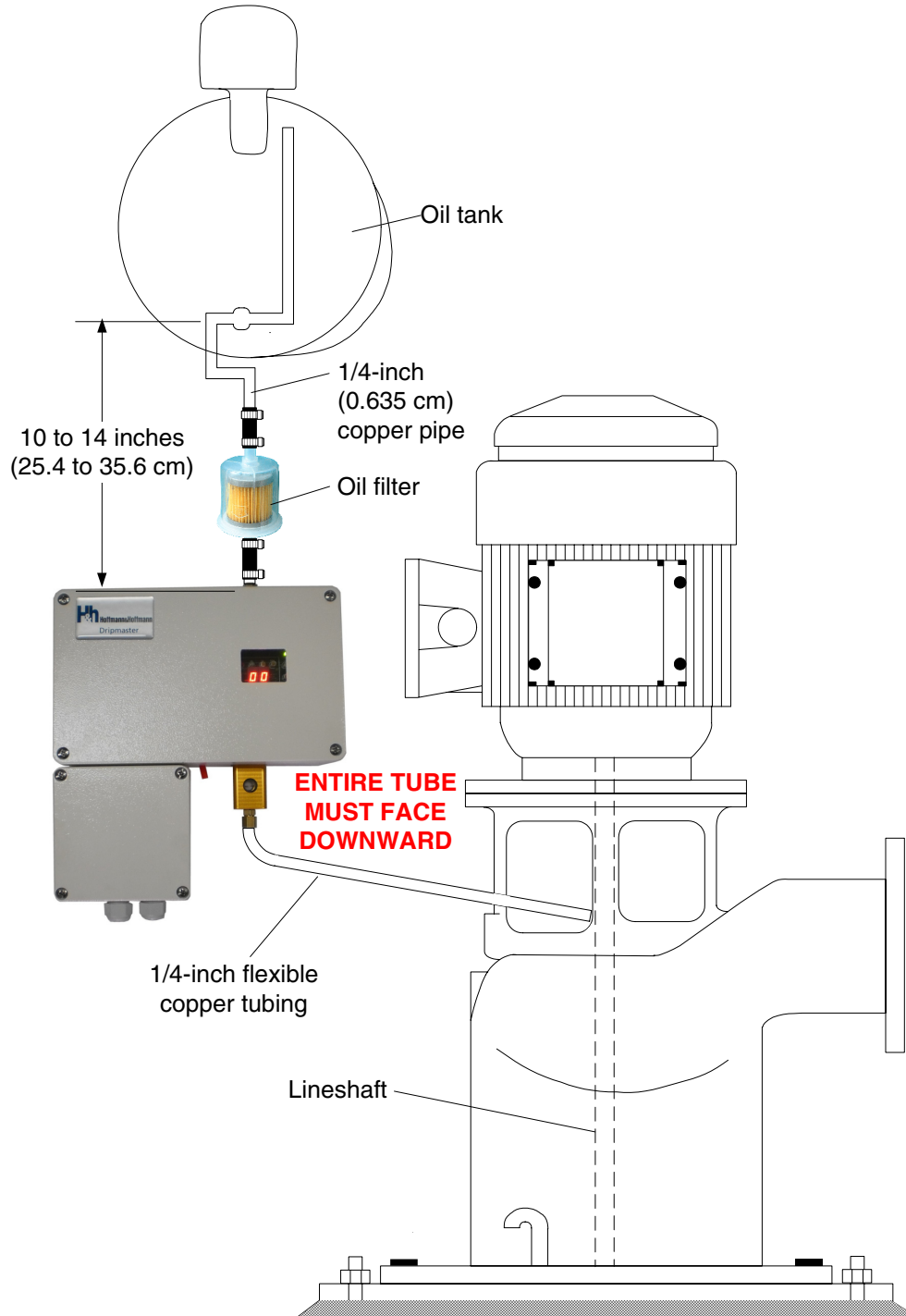

Figure 2: Installation requirements

Installation Kit

The Dripmaster is supplied with the following parts:

- 1 – oil filter (fuel filter for ¼-inch hose)
- 4 – mounting bolts
- 8 – nuts
- 8 – lock washers
- 2 – cable bushings (glands)

Make sure that all of the kit items are present. You need to obtain ¼-inch fuel hose to complete the installation.

Mounting the Dripmaster

1. In order to mount the Dripmaster, drill four 1/4-inch holes in the metal plate that mounts the Dripmaster according to the drilling template shown in Figure 3.

Note: The mounting centers for the Dripmaster are shown on the back of the unit for convenience. Mounting the unit does not require more than four bolts.

2. Remove the Dripmaster front covers.
3. Place a bolt into a mounting hole, and keep it in place by using a nut.
4. Repeat step 3 for the other bolts.
5. Secure the device to the metal plate using the remaining nuts and lock washers.

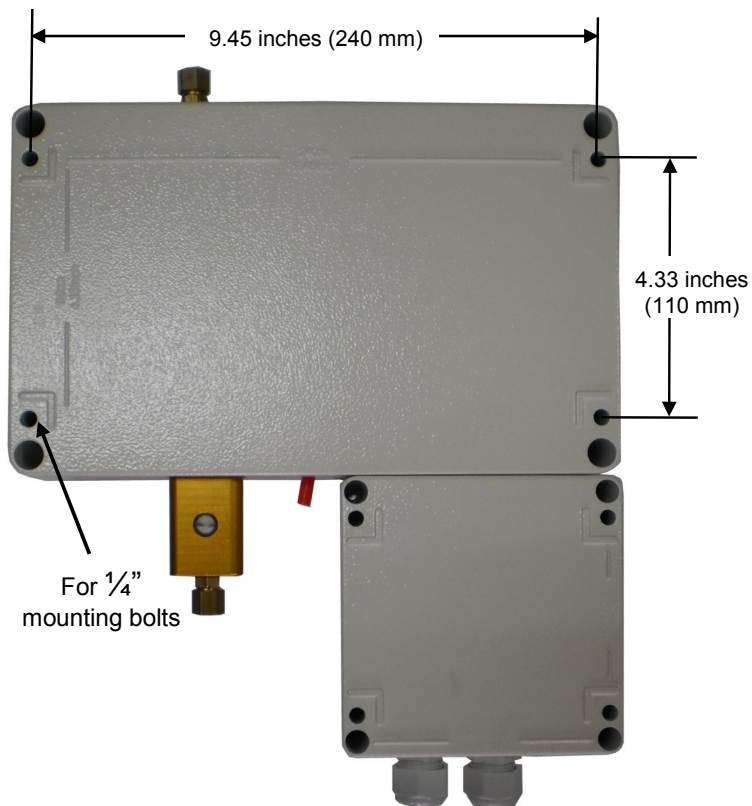

Figure 3: Dripmaster—rear view showing mounting centers

Wiring the Power and Control Cables

Power and control cables are routed through the bottom of the connection box through two strain relief bushings.

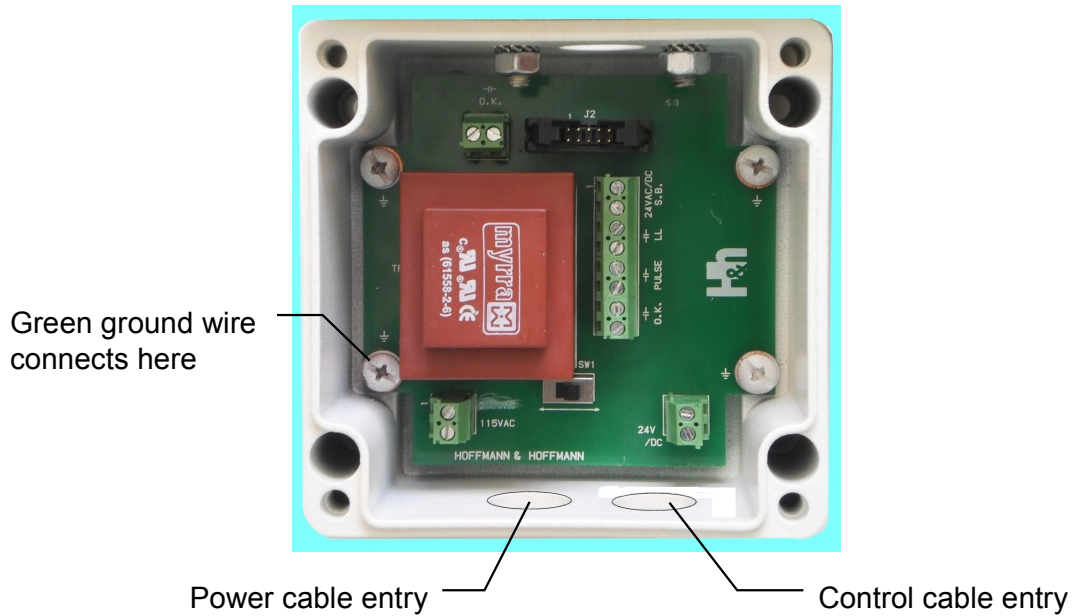

Figure 4: Connection box – cable routing

Wire the connection box according to Figure 5. Connections are described in detail in Table 1 on page 11.

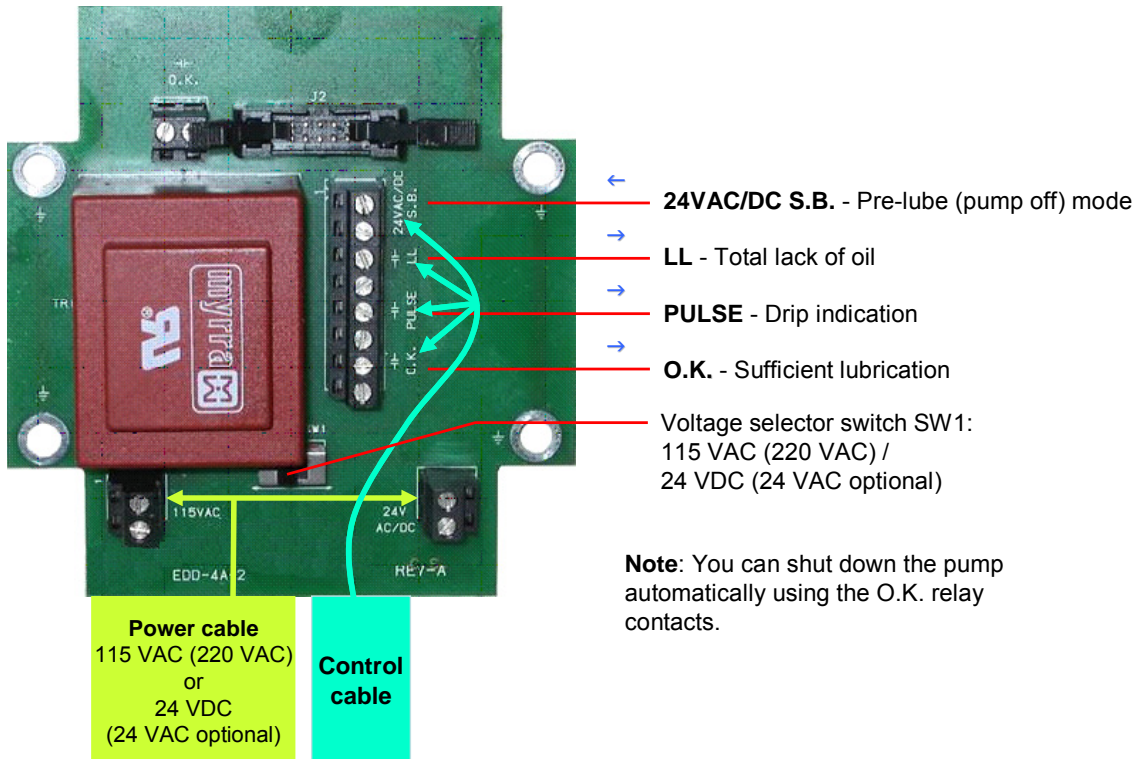

Figure 5: Connection box – electrical terminals: 115 VAC unit shown

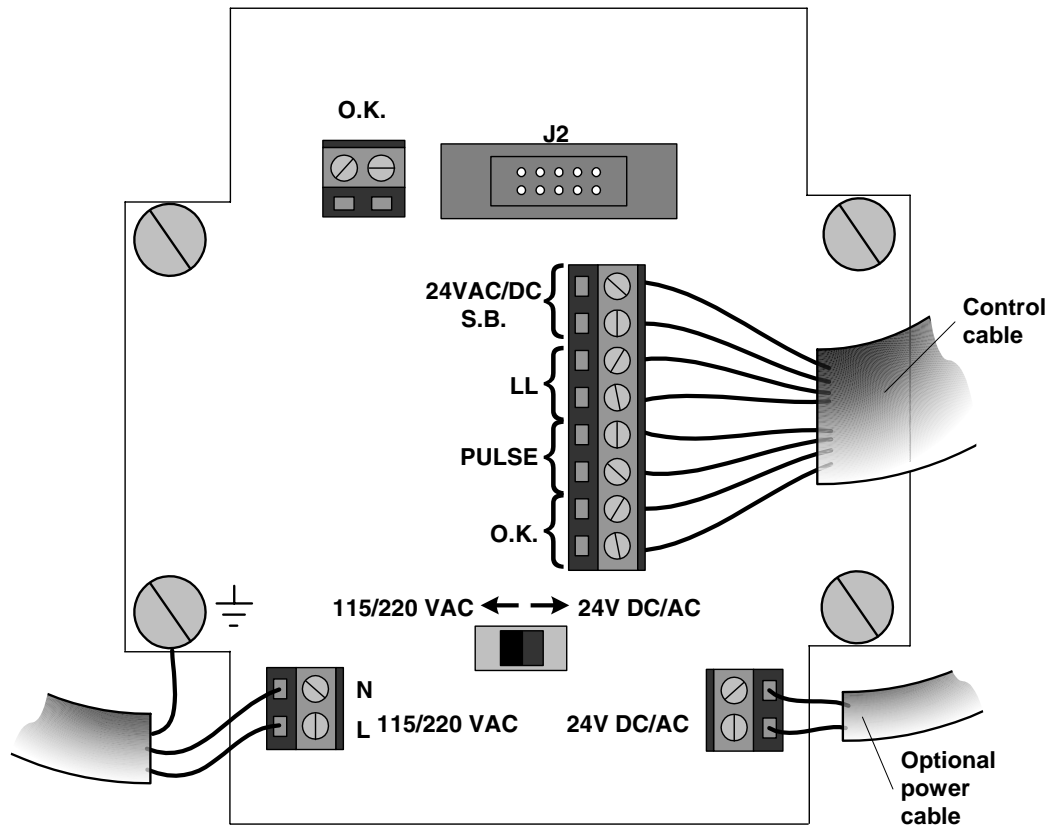

Figure 6: Connection box PCB – wiring diagram

Note: Line voltage is either 115 VAC, 60 Hz or 220 VAC, 50 Hz. The unit can be powered by line voltage or optionally by 24 V (DC or AC).

Note: Each of the signals associated with the control signal terminal block are **not** polarity dependent (24VAC/DC S.B., LL, PULSE, and O.K.).

Note: Avoid daisy-chain connections of the control signal returns – if the ground potentials of each return differ.

1. Set the power switch SW1 located just below the transformer, for line power (115 VAC or 220 VAC) or 24 V DC/AC according to your requirements. See Figure 5.
2. Route the power cable through a cable strain relief on the left side of the connection box (Figure 4).
3. Connect the green ground wire to a chassis screw or bolt, preferably using a ring terminal. See Figure 4.
4. Route the control cable through the right cable strain relief (Figure 4).
5. Connect control cable according to Table 1.

The connection box power and control line descriptions are shown below.

Table 1: Connection box—power and control lines

Cable or Terminal (Figure 5)	LED indicator (Figure 7)	Function
Power Cable (contains 3, 18 AWG wires)		This cable provides power to the Dripmaster. Using the selector switch and appropriate terminal block, for line power (115 VAC or 220 VAC) or 24 V DC/AC can be supplied.
Control Cable (contains 8, 22 AWG wires):		Input and output control or status signals are routed through this cable.
24VAC/DC S.B. – Pre-lube mode	SB	When applying 24 V DC/AC to these terminals, the Dripmaster switches to the Pre-lube (pump off) mode. The Dripmaster rate is 2 dpm in this mode. The SB LED (item 3 in Figure 7) also lights. See page 13).
LL – Total lack of oil	OIL	A dry contact that closes when a total lack of oil condition occurs. The OIL LED (item 1 in Figure 7) also lights. See page 13.
PULSE – Drip indication	DRIP	A dry contact that transmits the drip rate. The contact closes for every drop fed to the line-shaft. The DRIP LED lights momentarily whenever an oil drop passes through the Dripmaster.
O.K. – Sufficient lubrication ¹	OK	A dry contact that closes when at least 8 dpm of oil is present. This contact closes and the OK LED (item 2) in Figure 7 lights. See page 13.

¹ In the Pre-lube (pump off) mode, the OK contacts are always closed.

When the pump is on and the Dripmaster is in Normal mode, the OK signal indicates that oil is provided to the well pump in excess of 8 dpm (which is the factory preset threshold). Also, when the pump is on and the drip rate falls below 8 dpm, the OK relay contacts open and signal to the pump drive circuit to shut down the pump.

There are two possible scenarios when the Dripmaster is switched to the Normal mode:

1. The Dripmaster was in the Pre-lube (pump off) mode and dripping 2 dpm. When the pump is turned on, the Dripmaster is no longer in the Pre-lube mode but switches to the Normal mode (the 24 V applied to the SB terminals shown in Figure 6 have been removed).
2. The Dripmaster was de-powered when the pump was turned off, thus dripping 0 dpm (solenoid de-energized).

For the scenario in step 1, the Dripmaster initially drips 2dpm and gradually opens the needle valve in order to deliver the preset drip rate (10 to 28 dpm). This process takes approximately four minutes. Initially, the OK relay contacts are open and the OK LED is off, since the 8 dpm threshold has not yet been reached. This OK state is actually the pump shut down signal.

Note: In order to avoid this transition period OK signal, we recommend switching the Dripmaster to Normal mode (removing the 24V from the S.B. terminals) four to five minutes **prior** to starting up the pump driver.

For the scenario in step 2, after the Dripmaster has been powered up, it will immediately drip oil at the rate which is close to the preset drip rate (10 to 28 dpm), the OK contacts close and the OK LED is on.

Table 2: Pump On/Off conditions

Status	OK LED on	OK LED off
Pump on	<ul style="list-style-type: none">• Drip rate greater than 8 dpm• O.K. relay contacts are closed	<ul style="list-style-type: none">• Drip rate less than 8 dpm• Total lack of oil (OIL LED on)• O.K. relay contacts are open
Pump off	<ul style="list-style-type: none">• Drip rate is equal to or greater than 2 dpm• O.K. relay contacts are closed	<ul style="list-style-type: none">• Total lack of oil (OIL LED on)• O.K. relay contacts are open

6. Connect the oil filter (supplied) to the oil tank (Figure 2).

Important: The oil filter is essential as it prevents blockage in the needle valve.

7. Connect the Dripmaster oil outlet (Figure 8 on page 19, and Figure 2) to the well shaft inlet by means of flexible ¼-inch copper tubing.

Setting the Drip Rate

1. Set the dip switch settings for the Normal (pump on) mode using the drip rate setting toggle switches. (see Setting Normal (pump on) Mode on page 16).

Note: There are 50 drops per 1 cc, and there are 3785.4 cc per gallon.

2. Replace both covers and tighten the eight cover screws so that the unit is watertight.

Section 3: Operation

Controls and Indicators

Button and indicator locations on the Dripmaster control panel are shown below.

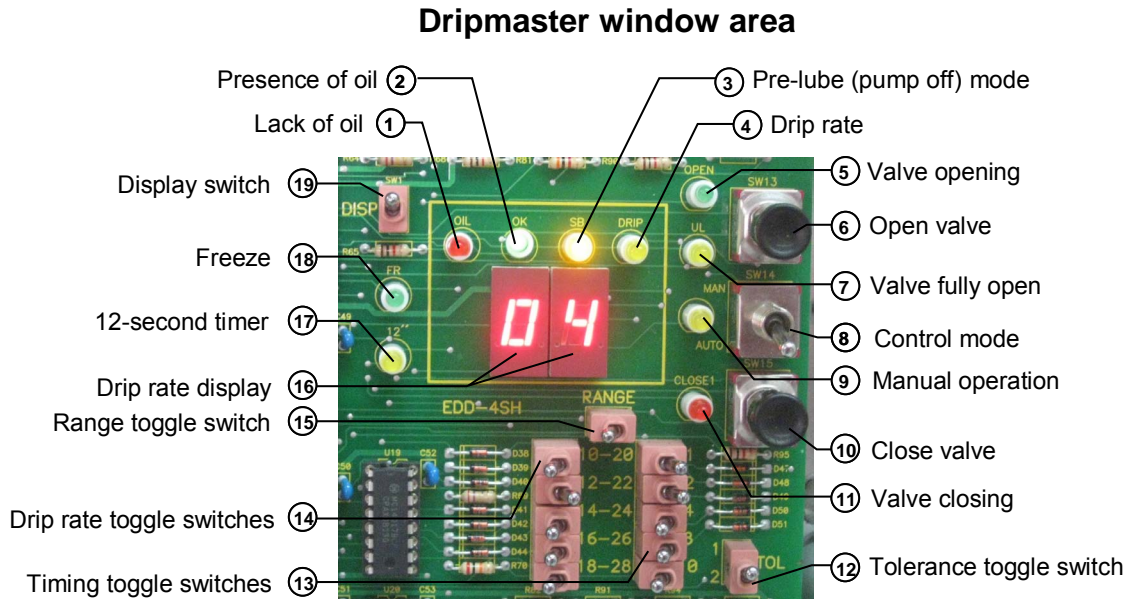

Figure 7: Dripmaster control panel

Table 3: Control panel—controls and indicators

Item number (Figure 7)	Name	Control or Indicator	Function
1	Oil	Red LED	Lights if the valve is completely closed, indicating a complete absence of oil. A corresponding relay contact closes when this LED is on. The terminal for this contact is called LL (Lower Limit) and appears in Figure 5 on page 9. This LED requires the user to reset the system after resolving the oil shortage issue (see Resetting the Dripmaster on page 16).

Item number (Figure 7)	Name	Control or Indicator	Function
2	OK	Green LED	<p>Indicates that sufficient oil is delivered whether the well pump is on or off.</p> <p>In the Normal (pump on) mode, this corresponds to oil drip rates in excess of 8 dpm.</p> <p>In the Pre-lube (pump off) mode, the LED lights when the rate is between 1 and 8 dpm. The LED is off when a total lack of oil condition occurs, and the OIL LED lights.</p> <p>A corresponding relay contact closes when the OK LED is on. The terminal for this contact is called O.K. and appears in Figure 9 on page 9. This terminal can be used to directly turn off the well pump in the Normal (pump on) mode, when drip rates are less than 8 dpm.</p>
3	SB	Yellow LED	Lights in the Pre-lube (pump off) mode when 24 V DC/AC is applied to the S.B. terminals in the connection box. The drip rate in this mode is always 2 dpm.
4	DRIP	Yellow LED	This LED flashes whenever a drop passes the photoelectric sensors in the Dripmaster needle valve assembly (see Figure 11 on page 22). In the Pre-lube (pump off) mode, the DRIP LED flashes approximately every 30 seconds, indicating that oil is flowing to the line shaft at a 2 dpm rate.
5	OPEN	Green LED	Lights when the motor is opening the valve.
6	Open Valve SW13	Push button	Press to manually open the valve—for troubleshooting, and can be used to shorten the time to reach the preset drip rate.
7	UL	Yellow LED	Lights when the valve is completely open.
8	Control mode SW14	Toggle switch	<p>Select between manual and automatic operation:</p> <ul style="list-style-type: none"> • Manual (MAN): for emergency use only. In this state, you can only open or close the needle valve manually by pressing the close valve or open valve push buttons. • Automatic (AUTO): the Dripmaster should always be in this mode for full Dripmaster functionality.
9	MAN	Yellow LED	Lights in the manual mode—when the mode switch (item 8) is in the up position
10	Close Valve SW15	Push button	Press to manually close the valve—for troubleshooting, and can be used to shorten the time to reach the preset drip rate.

Item number (Figure 7)	Name	Control or Indicator	Function
11	CLOSE	Red LED	Lights when the motor is closing the valve.
12	TOL	Toggle switch	Recommended tolerance is 1 (switch raised). Setting 2 (lower position) is for factory tests.
13	Timing	Toggle switches	These switches are set according to the section "Setting Normal (pump on) Mode Drip Rates", starting on page 16.
14	Drip Rate	Toggle switches	Sets the drip rate for the pump-on mode. Choose only one toggle switch, and push it up to the desired dpm value.
15	SW 2 – Range	Toggle switch	Low Range is selected with the switch left. Low Range allows 10,12,14,16, or 18 dpm. High Range is selected with the switch right. High Range allows 20, 22, 24, 26, or 28 dpm.
16	Drip rate	7-segment Display	A two-digit display shows the drip rate count
17	12 ''	Yellow LED	Flashes every 12 seconds for timing purposes when in Normal mode. You can count the number of drips seen during this 12-second interval and multiply them by five to arrive at the dpm rate. This LED is useful when you want to quickly stabilize the drip rate by pressing the Open Valve (SW13) or Close Valve (SW15) push button.
18	FR	Green LED	Lights to indicate the six-second freeze interval when in Normal mode. During this interval, which occurs once per minute, the needle valve may be opened or closed in order to adjust the drip rate.
19	Display switch SW1	Toggle switch	Controls the two-digit numerical display: <ul style="list-style-type: none"> In the down position (recommended): When pump is on, displays the last minute drip count for a period of six seconds. The display goes off until the next minute drip count is displayed. When the pump is off (Pre-lube mode), the display remains off. The 2 dpm oil flow can be verified by looking at the DRIP LED. This LED should flash every 30 seconds. In the up position (used for factory tests only).

Resetting the Dripmaster

There are two ways to reset the Dripmaster:

1. By removing the Dripmaster cover, and raising the Control Mode toggle switch to the **MAN** position, and then back to the **AUTO** position.
 2. By disconnecting the power source to the Dripmaster for 10 seconds, and then reconnecting it.
- In both cases, the circuit voltage is interrupted and then restored.

Note: In case (2) above, a random drip rate is displayed initially which can be ignored.

Automatic Control

Make sure the Control Mode toggle switch SW14 is in the lower **AUTO** position (item 8 in Figure 7), so that the Dripmaster automatically stabilizes the preset drip rate. At the end of each 60 second interval, a short correction command is given only if there is a deviation from the desired preset drip rate.

The valve closes if the actual drip rate is 1 drip/minute or more than the preset value.

The valve opens if the actual drip rate is 1 drip/minute less than the preset value.

Setting Normal (pump on) Mode Drip Rates

During normal operation (when the well pump is operating), the drip rate is selectable for drip rates of 10, 12, 14, 16, 18, 20, 22, 24, 26, or 28 drips/minute (Figure 7).

The toggle switch positions for each drip rate are shown below.

10 dpm toggle switch setting

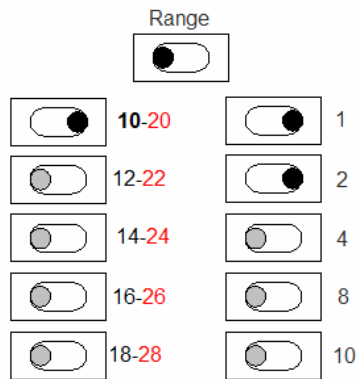

12 dpm toggle switch setting

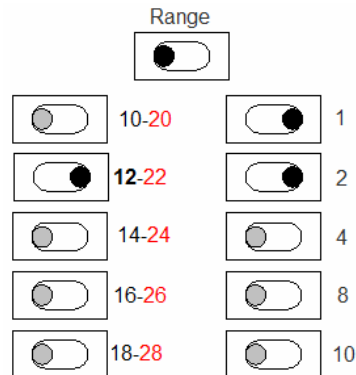

14 dpm toggle switch setting

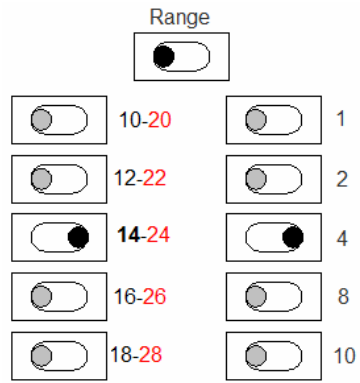

16 dpm toggle switch setting

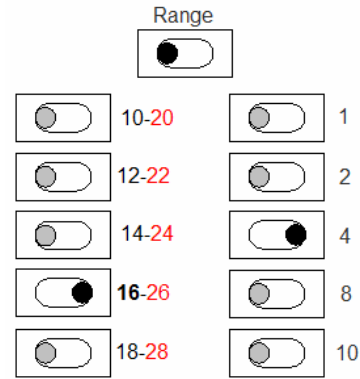

18 dpm toggle switch setting

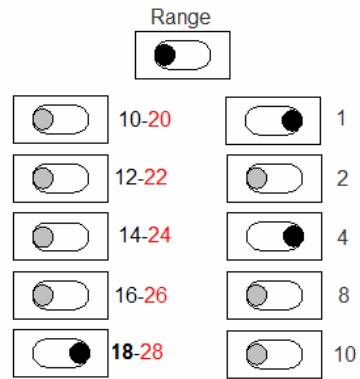

20 dpm toggle switch setting

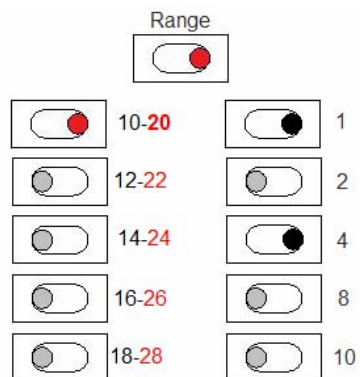

22 dpm toggle switch setting

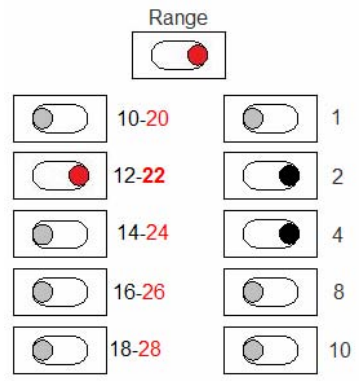

24 dpm toggle switch setting

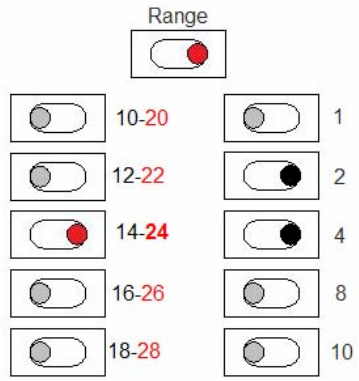

26 dpm toggle switch setting

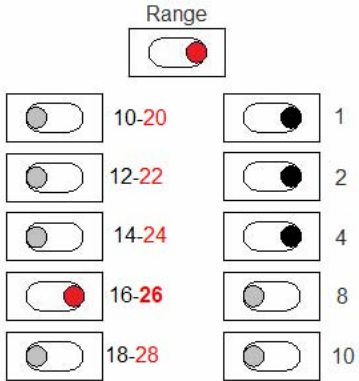

28 dpm toggle switch setting

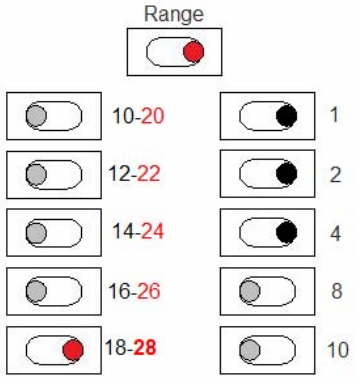

The **OPEN** and **CLOSE** LEDs indicate whether the needle valve is opening or closing. See items 5 and 11 in Figure 7 on page 13.

Pre-lube (pump off) Mode

To select the Pre-lube mode, 24 V DC/AC must be applied to the S.B. terminals in the connection box (Figure 5). In this mode, the drip rate is automatically set to 2 dpm.

Manual Control

This mode permits emergency operation in the rare case when there is a suspected failure of the main circuitry.

Select the manual mode by switching the Mode toggle switch to the upper **MAN** position (Figure 7). This mode bypasses the electronic control circuitry, and allows the operator to modify the drip rate by using the Open Valve (manual) and Close Valve (manual) push buttons.

Use the Drip verification peephole (see Figure 8 below) to check the drip rate.

In this mode, power is removed from the circuitry, except for the push buttons, motor, and Manual mode LED.

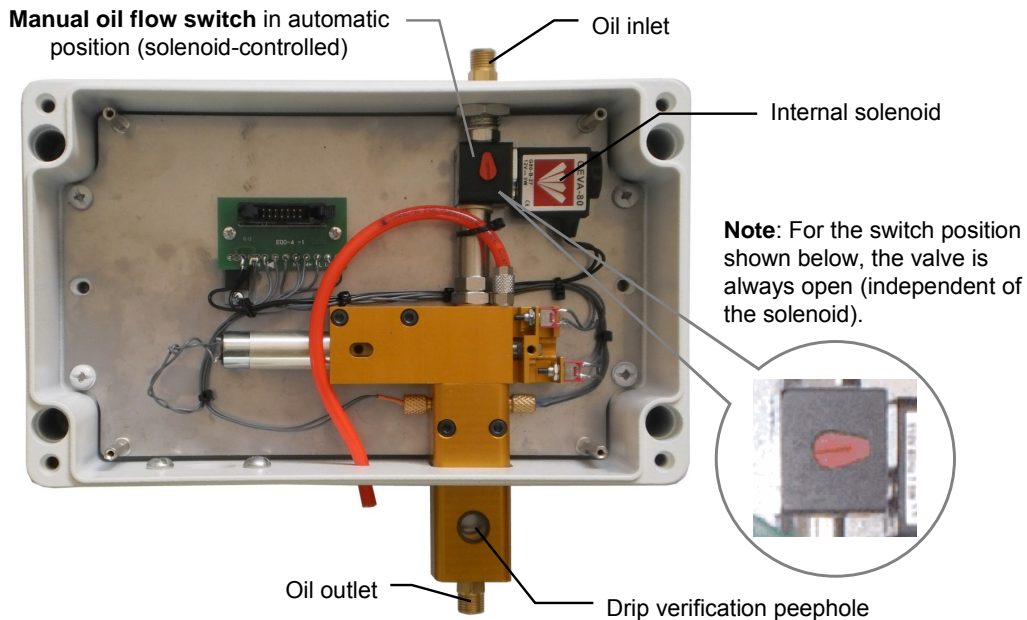

Figure 8: Dripmaster EDD-4SH Needle Valve Assembly

The internal solenoid is powered by the Dripmaster power source. When powered up, the solenoid allows oil flow. When powered down, the solenoid blocks oil flow.

To allow oil flow when the Dripmaster is not powered on, turn the manual oil flow switch to the right 90 degrees.

Section 4: Theory of Operation

General

The Dripmaster is a gravity-based oil lubrication system.

The common needle valve fed from an oil tank does not provide any regulation of the drip rate—the rate varies in response to variations in temperature (day versus night and time of year) and changes in the tank oil level (hydrostatic pressure). Another cause of rate fluctuation is temporary valve blockage.

The Dripmaster performs as an automatic needle valve that regulates oil flow (Figure 9).

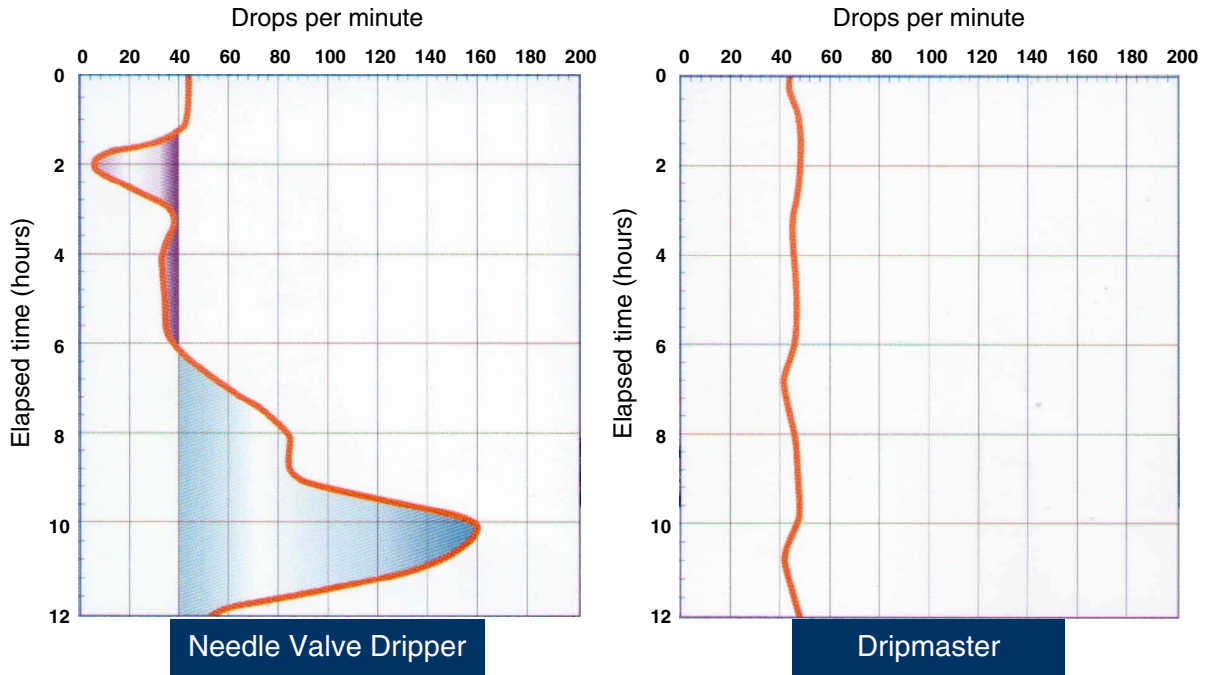

Figure 9: Common Needle Valve compared to Dripmaster

The components that make this possible are described below.

The servo motor regulates the needle valve aperture according to the preset drip rate value. A photoelectric sensor detects the drips and reports the drip count to the control circuitry. The control circuitry sets the mode of operation and generates the alarms and drip count information to the SCADA interface.

The Dripmaster EDD-4SH incorporates a specially-designed needle valve connected to a servo motor which automatically compensates for rate fluctuations. The compensation magnitude is defined by the control circuitry. For example, if the drip rate set point is 20 drips/minute, and the drip rate drops below that level for any reason, the servo motor that attaches to the needle valve opens it to increase the drip rate to maintain 20 drips/minute. Conversely, if the drip rate exceeds the set point, the servo motor closes the needle valve to maintain the set point value (Figure 10).

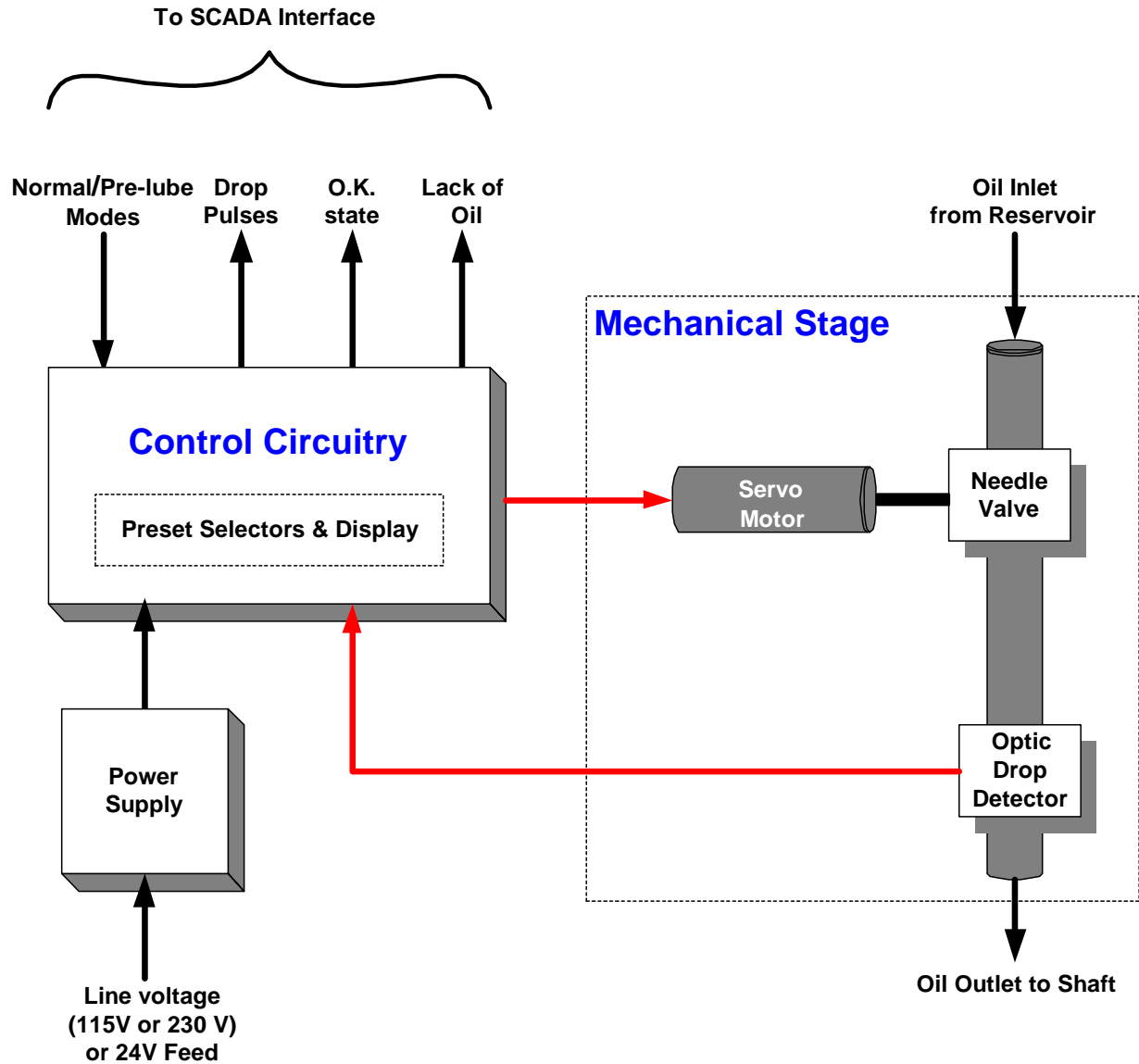

Figure 10: Dripmaster functional diagram

A two-digit display is visible in the Dripmaster display window (see Figure 7 on page 13)—this is a drip counter that freezes for six seconds for each one minute interval and indicates the number of drips applied during the previous minute (Freeze mode).

During the freeze period, the servo motor is actuated to compensate for drip rate deviations.

A built-in fail-safe relay (O.K. relay) is energized when the drip rate exceeds eight drips per minute in the Normal (pump on) mode. External dry relay contacts permit direct control, such as pump shut-off. Other dry contacts in the Dripmaster are available to transmit the drip rate, and for warning of a total lack of oil condition.

The Dripmaster EDD-4SH contains two drip rate settings, depending on the mode of operation:

- **Normal (pump on) mode**—the following values are selectable:
 - 10, 12, 14, 16, 18, 20, 22, 24, 26, or 28 drips/minute (dpm)
- **Pre-lube (pump off) mode**—in this mode, the drip rate is automatically set to 2 dpm.

A built-in, SCADA-compatible report-back mechanism provides the status and alarm information. This information is sent to the local PLC on site. The following signals are reported:

- **OK state** – signals that the oil drip rate exceeds a factory-set threshold. Whenever the oil drip rate falls below this threshold, the OK state is disabled and a relay contact can turn off the well pump directly or signal the SCADA room, which in turn can shut down the pump.
- **Drip rate count**– transmits the oil drip rate to the SCADA room, thereby providing the data to calculate oil consumption.
- **Lack of oil alarm** – the Dripmaster detects and warns of a lack of lubrication, as a result of an empty oil tank or blockage in the oil inlet or outlet.

Manual operation is possible using the OPEN and CLOSE push buttons on the control panel. The built-in peephole allows the operator to count the drips per minute.

Switching between the Pre-lube (pump off) mode and Normal (pump on) mode is accomplished by applying or removing a 24 V DC/AC voltage to the S.B. terminals in the connection box. Applying a 24 V DC/AC voltage sets the Dripmaster to the Pre-lube mode of operation. Removing the 24 V DC/AC voltage causes the Dripmaster to switch to the Normal (pump on) mode.

Search Feature

In exceptional cases, where only a few drops are counted, or none at all, the drip search function is activated. This situation occurs if there is needle valve blockage or when there is a continuous flow of oil. In the continuous flow case, there are no individual drops and consequently no counter readings. Continuous oil flow may occur when filling an almost empty oil tank, for example. In case of partial blockage, the drip search function scans until drops appear (the needle valve opens continuously until drops are detected). If no drops are detected during the drip search (if the oil blockage or continuous oil flow persists), then the needle valve eventually reaches its upper limit, the UL LED illuminates briefly, and the motor changes its direction of rotation and starts to close the needle valve (Figure 11).

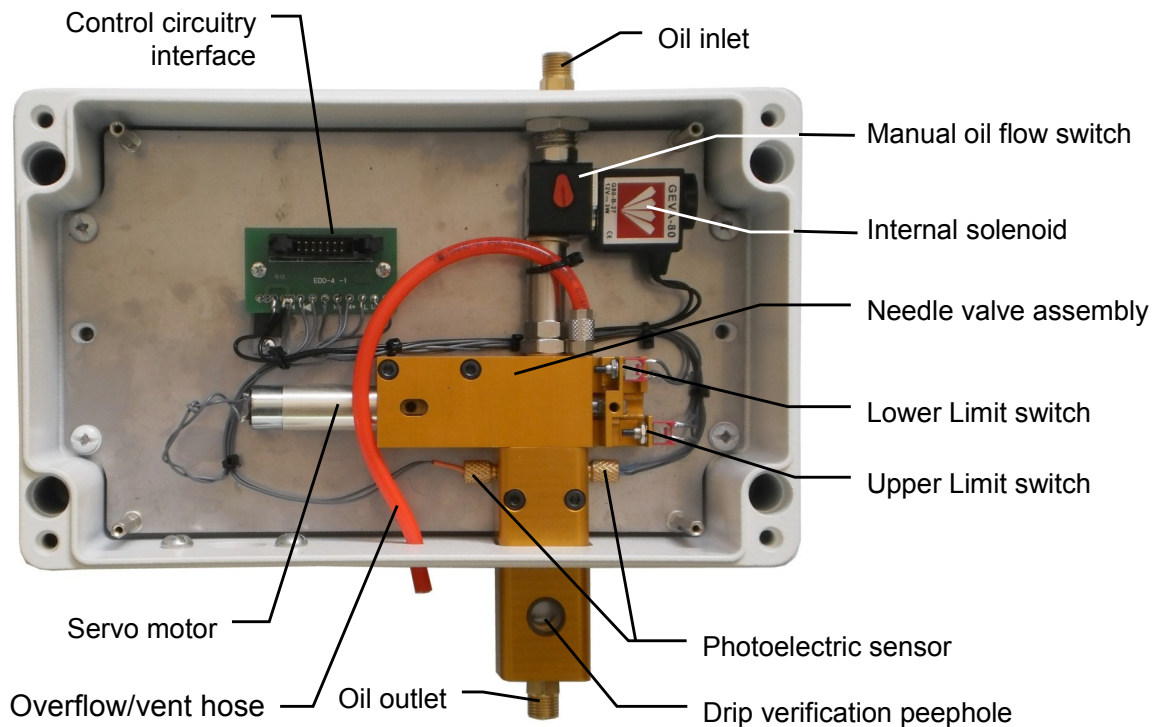

Figure 11: Dripmaster EDD-4SH Needle Valve Assembly

When and if oil drops are detected, the search function stops, and normal stabilization resumes. If no drops are detected while the needle valve is closing, then the needle valve eventually reaches its lower limit and the OIL LED lights continuously. The LL relay outlet contact closes, transmitting a total lack of oil condition. At this stage, there is no vertical line-shaft lubrication which means that either the oil tank is empty or there is an oil flow blockage between the oil tank outlet and the Dripmaster inlet.

In the case of oil flow blockage in the Dripmaster outlet pipe, excess oil briefly flows from a built-in overflow hose (see Figure 11 above). Also, the OIL LED turns on, and oil flow is cut off by the closure of the needle valve. After taking corrective measures, you must reset the system. See "Resetting the Dripmaster" on page 16.

The internal solenoid provides instantaneous on/off control of oil flow. Whenever the system power (115 VAC, 220 VAC, or 24 V DC/AC) is on, the energized solenoid allows oil flow. Oil flow stops when the system power ceases. The oil flow can be manually opened or closed via the manual oil flow switch (Figure 11). When the solenoid switch is in the vertical position, operation is automatic (controlled by the solenoid). Turn the solenoid switch 90 degrees clockwise to the horizontal position for continuous oil flow that is independent of the solenoid.

Push-Down and Push-up Features

In order to enhance the response time of the system whenever the drip rate exceeds 80 dpm, an automatic push-down mechanism is engaged. This is achieved by continuously closing the valve for a number of seconds. Excessive drip rates may occur when filling an empty oil tank, or when the Dripmaster has finished scanning.

Similarly, an automatic push-up mechanism accelerates the stabilization of the system whenever the Dripmaster is transferred from the Pre-lube (pump off) mode to the Normal (pump on) mode. This mode change occurs when the 24 V DC/AC is removed from the S.B. terminals in the connection box.

Section 5: Maintenance and Troubleshooting

Table 4: Routine Maintenance

Task	Frequency
Check for oil leaks	Monthly
Oil filter change (the oil filter used can be an automotive fuel filter with ¼" fittings)	Every six months
Check for normal operation <ul style="list-style-type: none"> The displayed drip rate is equal to the Normal (pump on) mode drip rate setting, within a -1, +1 digit tolerance 	Weekly

Table 5: Troubleshooting

Problem	Possible Cause	Solution
The display and LEDs are not lit.	<ul style="list-style-type: none"> The unit is not powered. 	<ul style="list-style-type: none"> Check power in the connection box.
An unusual result appears on the display	<ul style="list-style-type: none"> Changing the mode toggle switch (item 8 in Figure 7 on page 13). 	<ul style="list-style-type: none"> Ignore.
You want to quickly stabilize the Dripmaster for a new drip rate	<ul style="list-style-type: none"> You just refilled the oil tank. You just increased the drip rate setting in the Normal (pump on) mode. 	<ul style="list-style-type: none"> With the Mode toggle switch (item 2 in Figure 7 on page 13) in automatic (AUTO), hold down the Close push button momentarily to slow down the drip rate. With the Mode toggle switch in position AUTO, hold down the Open push button momentarily to speed up the drip rate.
A suspected fault has occurred in the system; the drip rate is much higher or lower than expected.	<ul style="list-style-type: none"> Circuit failure 	<ul style="list-style-type: none"> Set the Mode switch to MAN, and set the drip rate manually using the Open and Close push buttons. See Figure 7.

Problem	Possible Cause	Solution
The OIL LED is on.	<ul style="list-style-type: none"> • Oil tank is empty • A shut-off valve at the outlet of the oil tank might be closed • Oil flow from the oil tank may be obstructed; the oil filter may be clogged • Oil blockage between the Dripmaster outlet pipe and the line-shaft—excessive oil briefly flows from a built-in overflow hose 	<ul style="list-style-type: none"> • Refill the oil tank • Open the shut-off valve • Change the oil filter, or clean out any obstructions in the pipe between the oil tank and the Dripmaster inlet • Clean out any obstructions in the pipe between the Dripmaster outlet and the line-shaft. <p>Note: Reset the system after fixing the problem. See Resetting the Dripmaster on page 16. Initially, the drip search is engaged within 90 seconds. The drip search causes the motor to open the needle valve until drops are detected, after which normal stabilization occurs.</p>

Section 6: Specifications

Table 6: Dripmaster EDD-4SH specifications

Power requirements	115 VAC, 60 Hz, 10 VA, or 24 V DC/AC 220 VAC, 50 Hz, 10 VA or 24 V DC/AC
Normal mode preset drip rates (pump on)	10, 12, 14, 16, 18, 20, 22, 24, 26, 28 dpm
Pre-lube mode drip rate (pump off)	2 dpm
Drip volume	50 drops per 1 cc
PULSE relay contact	35 VDC – 0.5 A
O.K. relay contact	250 VAC – 10 A AC1 110 VAC – 10 A AC1 110 VDC – 0.3 A 30 VDC – 10 A
L.L. (low oil level) relay contact	125 VAC – 0.5 A 110 VDC – 0.2 A 24 VDC – 1 A
S.B. (Normal/Pre-lube mode control)	24 V DC/AC
Duty cycle	60 secs count 6 secs freeze
Drip stabilizing tolerance	x when SW 18 is UP x to x+1 when SW 18 is DOWN (where x is the pre-selected drip rate)
Oil on/off solenoid	24 VDC 24 VAC (optional)
Oil inlet/outlet	Male thread ¼" BSP
Dimensions (W x H x D)	10.24 x 11.02 x 3.54 inches (260 x 280 x 90 mm)
Weight	11 lbs (5 kg)

All specifications shown are subject to change.

Table 7: Oil volume fed to line shaft

Drip Rate (dpm)	2	10	12	14	16	18	20	22	24	26	28
Volume: ml/ hour	2.4	12	14.4	16.8	19.2	21.6	24	26.4	28.8	31.2	33.6
Volume: gal./ day	0.015	0.076	0.090	0.105	0.12	0.135	0.15	0.165	0.18	0.195	0.21

Volume figures are based on a Dripmaster drop volume of 50 drips = 1 ml.

Overall Dimensions

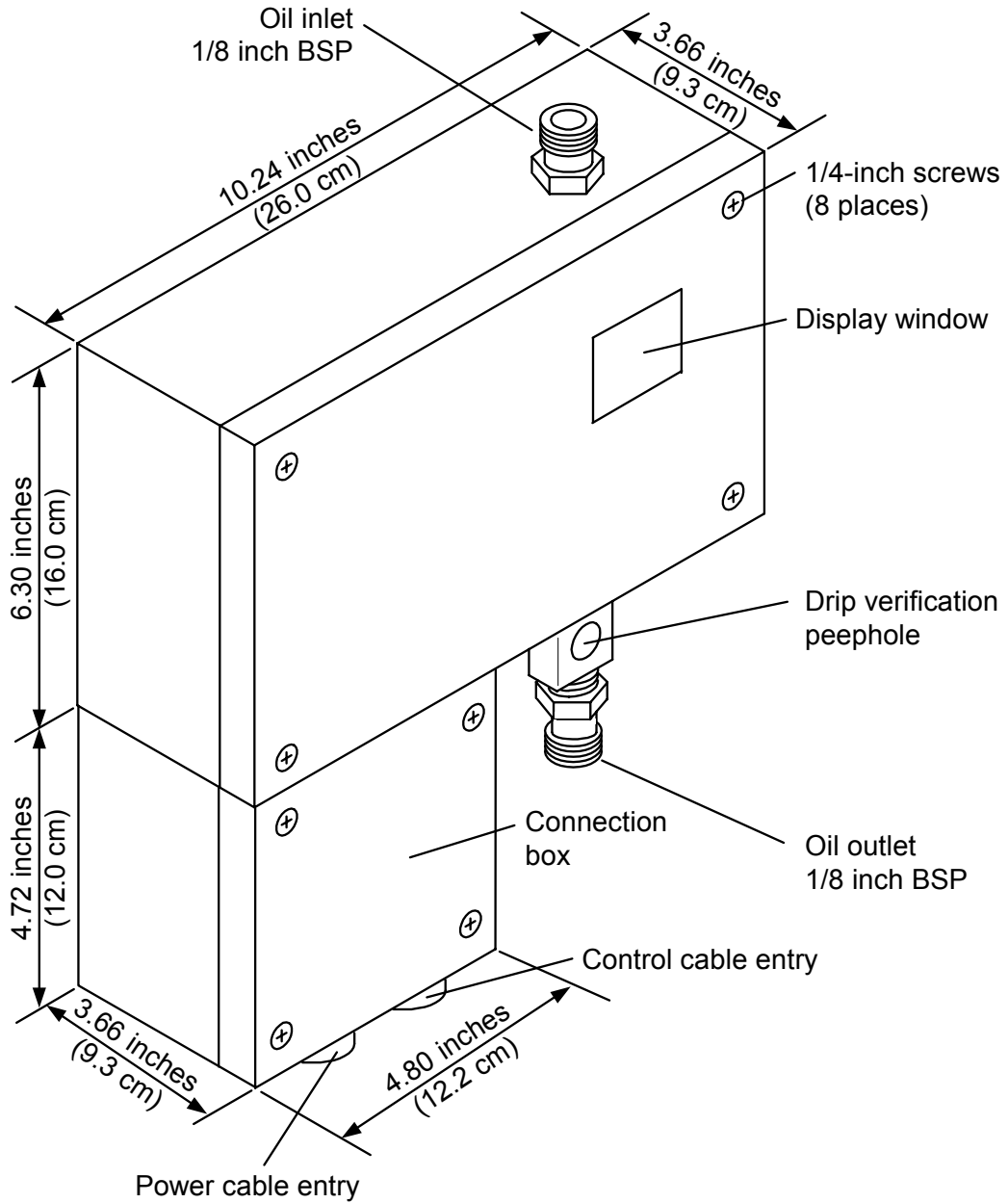

Figure 12: Dripmaster dimensions

The Dripmaster enclosure is made of painted, cast aluminum.

Section 7: Dripmaster Service Policy

This policy has been established to cover the servicing of Hoffmann & Hoffmann products, regardless if it is within or beyond the warranty period.

Installation

1. The installation services required for the Dripmaster includes the following:
 - a. Infrastructure (trench digging, cable laying)
 - b. Oil tank stand
 - c. Dripmaster mount
 - d. Cabling (4 pairs)
 - e. 24V (DC or AC) power source
 - f. Testing
2. Hoffmann & Hoffmann's representative or its authorized subcontractors will perform the installation work required and charge the customer directly.
3. In cases where there is a prior approval by Hoffmann & Hoffmann, the customer may do the installation.
4. The representative will assume full responsibility for the installation work he performs.

Repair procedure

1. In case of a default, the customer can follow the Troubleshooting table (Table 5 on page 24) to try and solve the problem.
2. If the customer does not succeed in solving the problem, he can fax or email Hoffmann & Hoffmann's local representative, describing the problem based on the Troubleshooting table (Table 5 on page 24), and indicating which of the procedures failed ("the notice"). This should be directed to the local representative where he has a service agreement.
3. Hoffmann & Hoffmann's representative will respond within two working days.
4. The problem might be fixed by the representative in one or more of the following ways:
 - a. **Remotely:** instruct the customer on how to solve the problem by phone.
 - b. **On Site:** technician arrives at the customer's site to perform first level support (basic repairs and parts replacements).
 - c. **In Hoffmann & Hoffmann lab:** ship the unit to Hoffmann & Hoffmann's Chicago office.
5. The representative should first try to solve the problem remotely.
6. In case the problem is not solved remotely, the representative will send a technician to solve the problem on site, within two working days.
7. If the representative concludes that the problem can only be solved in Hoffmann & Hoffmann's lab, he should disconnect the unit and ship it to Hoffmann & Hoffmann's Chicago office.
8. The representative has the option to replace the faulty unit with one of his spare units.
9. The repaired unit should be shipped back from Hoffmann & Hoffmann to the representative.
10. The representative will send the repaired unit, with the repair invoice and shipment cost, to the customer.

PC Board Replacement in the Field

11. Remove both covers to gain access to the PC boards, and then follow directions shown in Figure 13 below.

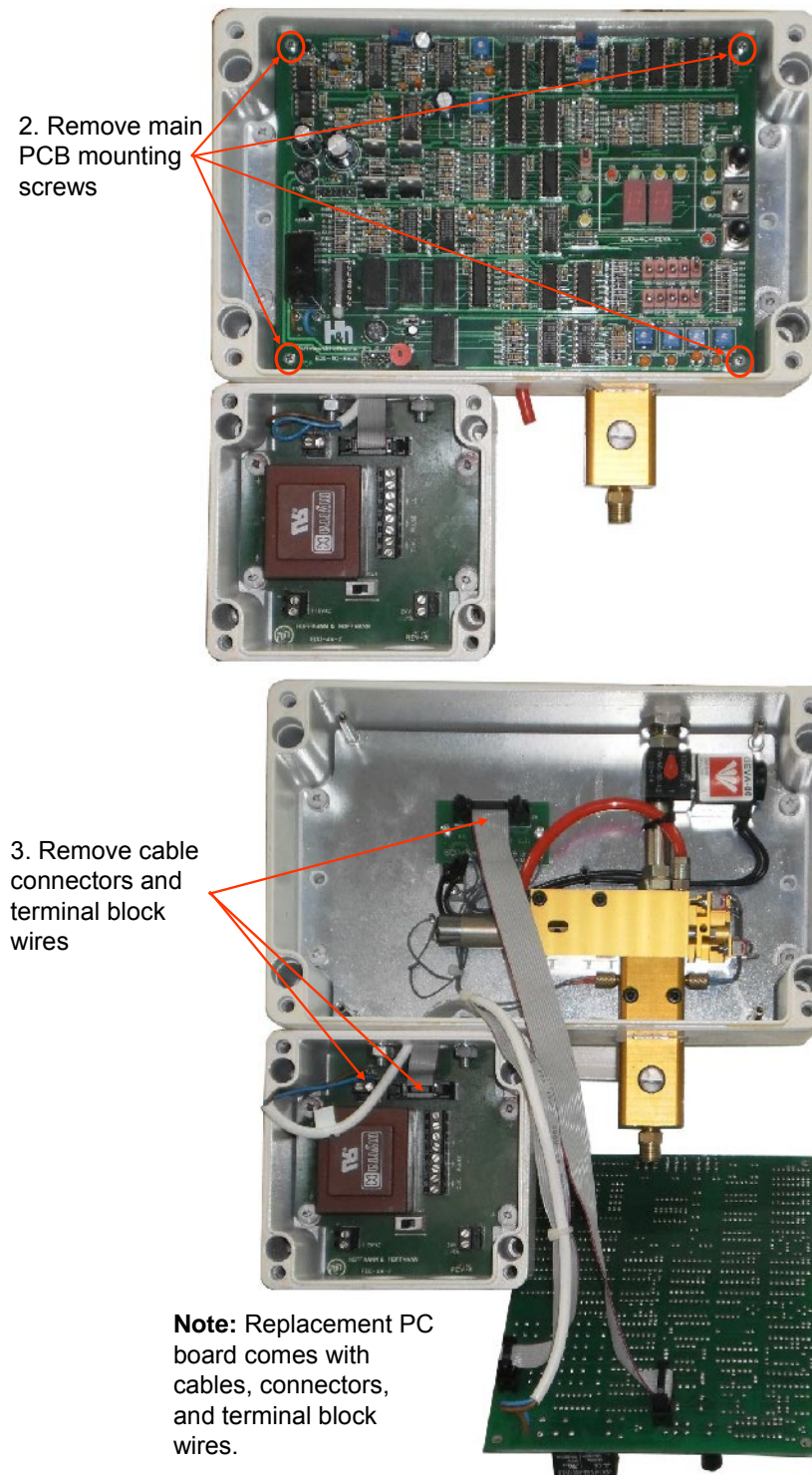

Figure 13: Dripmaster PC board replacement

Reverse procedure above to install the replacement PC board

Product within the Warranty Period

1. All Hoffmann & Hoffmann products have a one year limited warranty.
2. Hoffmann & Hoffmann Warranty will apply only to units installed by authorized Rep/Distributors or by the customer (if Hoffmann & Hoffmann authorized installation by the customer).
3. Hoffmann & Hoffmann is not responsible for damages caused by extreme environmental factors, i.e. temperature extremes.
4. If the failure occurred during the Warranty Period, Hoffmann & Hoffmann will cover the repair cost. The customer will only pay for the shipment to the nearest Hoffmann & Hoffmann office.

Product Out-of-Warranty Period

1. If product is not under warranty, the customer will be responsible for all of the repair cost as per his agreement with the representative including:
 - Technician labor cost
 - Spare parts cost
 - Other expenses (travel, shipment)
2. **Repairs at Hoffmann & Hoffmann lab:** if the product arriving to the lab is out of the Warranty Period or if failure is deemed by the factory to have been caused by abuse or tampering, the following procedure applies:
 - a. Diagnosis will be made and repair completed, providing the repair charges are less than \$500 USD.
 - b. We will diagnose (but not repair) a returned unit and notify by email or by fax the estimated charges if any of the following apply:
 - i. Repair charges exceed \$500 USD.
 - ii. You specifically requested an estimate of required repairs and charges.
 - iii. When the product is over 7 years old. Hoffmann & Hoffmann takes pride in attempting to repair products of any age. However, due to component availability and product improvements, some older products may no longer be repairable.
 - c. When you receive an estimate and would like us to proceed, please mail or fax one signed copy (with P.O. number if required) or phone or email your authorization.
 - d. **Note:** Un-repaired items are discarded unless you wish them to be returned to you. There is currently a \$150 charge plus shipping per un-repaired item to cover diagnosis and handling such returns. Items remaining more than 90 days from estimate date will be discarded.
 - e. Service warranty period is ninety days for all repaired/replaced parts.

Return Instructions

1. When sending your product for repair, please include the following information:
 - a. Company name and address
 - b. Contact name
 - c. Phone, fax and/or email
 - d. Description of the problem(s)

2. Return properly packaged item to the address of your local Rep/Distributor or to Hoffmann & Hoffmann lab.
3. This warranty is limited to the repair or replacement of the Hoffmann & Hoffmann products only. Hoffmann & Hoffmann assumes no other responsibility or liability.
4. Hoffmann & Hoffmann reserves the right to make changes in policy and pricing without notice.

Terms & Conditions on reverse

The purchaser agrees to the following terms and conditions:

1. **Shipping:**
 - a. If not specified, goods will be shipped by the most economical carrier of our choice. Domestic orders will be shipped GROUND unless specified. International orders will be shipped AIR unless specified.
 - b. To obtain warranty service, you must deliver the product in either its original packaging or packaging affording an equal degree of protection.
2. **Insurance:** Insurance costs will be added to all invoices.
3. **F.O.B.: Free On Board.** ALL goods are shipped F.O.B. All shipping and insurance costs, local and/or foreign taxes or exportation / importation duties are the responsibility of the customer.
4. **Claims:** Claims for damage sustained in transit should be made promptly to your carrier.
5. **Force Majeure:** Hoffmann & Hoffmann shall not be liable for any delay in or impairment of performance resulting in whole or part from acts of nature, labor disruptions, shortages, inability to procure product, supplies or raw materials, severe weather conditions, or any other circumstances or cause beyond the control of Hoffmann & Hoffmann in the conduct of its business.



Corporate office:

Hoffmann & Hoffmann Ltd., 7 Shoham Str., P.O.Box 7544, Petach Tikva 49170, Israel
Tel: 972-3-923-2567; Fax: 972-3-923-2575; E-mail: info@hw-well.com

USA office:

Hoffmann & Hoffmann, 2757 W. Jarlath Str., Chicago, Illinois 60645
Tel: 312-277-9191; 312-218-8997; Fax: 866-272-8433; E-mail: info@hw-well.com

www.hw-well.com
