



# SMVT

VERTICAL MULTI-STAGE PUMP

### SMVT PRODUCT LINE NUMBERING SYSTEM

The various versions of the SMVT line are identified by a product code number on the pump label. This number is also the catalog number for the pump. The meaning of each digit in the product code number is shown below.

**Note:** Not all combinations are possible. Consult your Goulds Water Technology distributor.

**Example Product Code: SM3A1J2C1VA**

#### Product

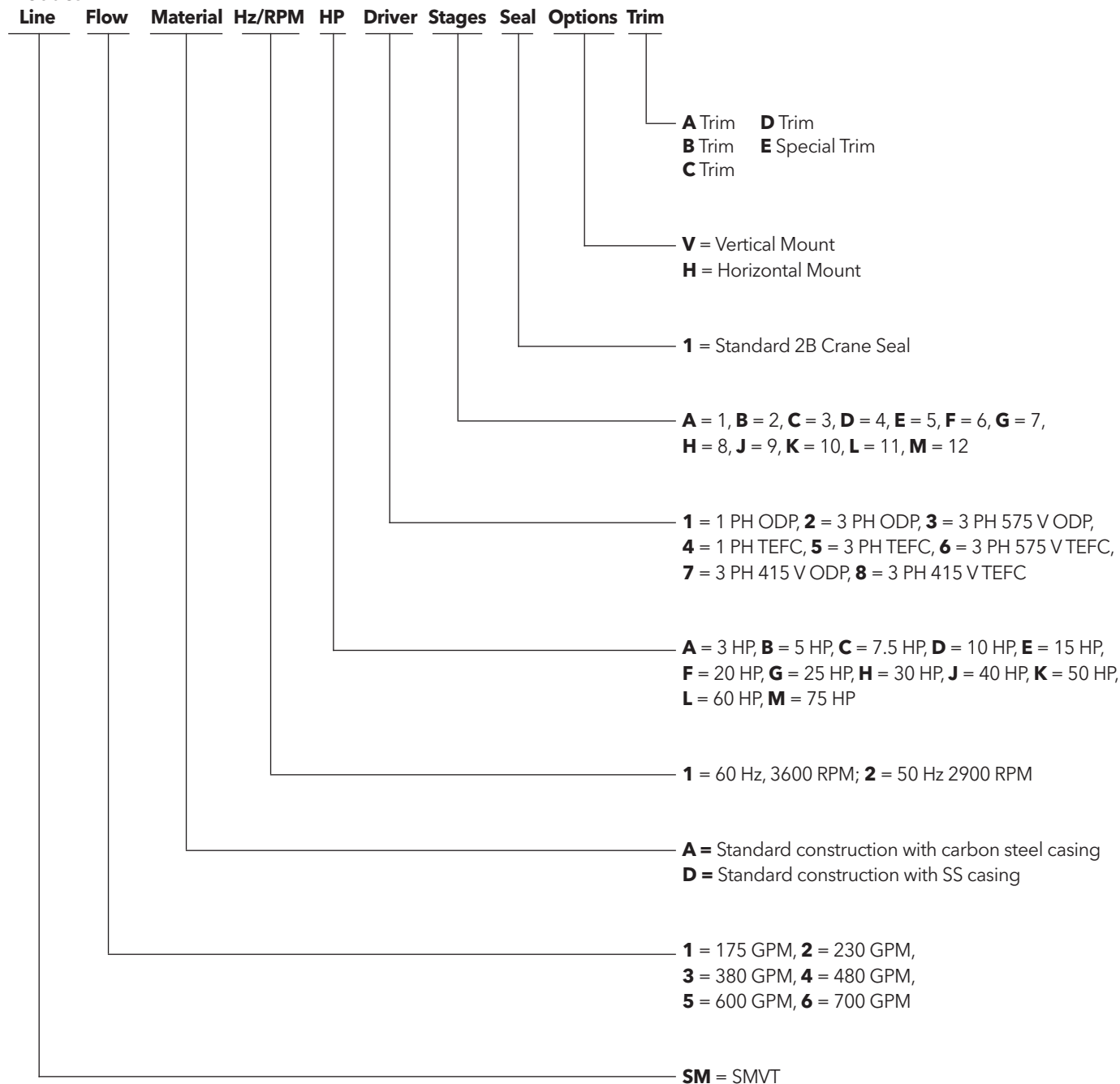

### SMVT SECTIONAL ASSEMBLY

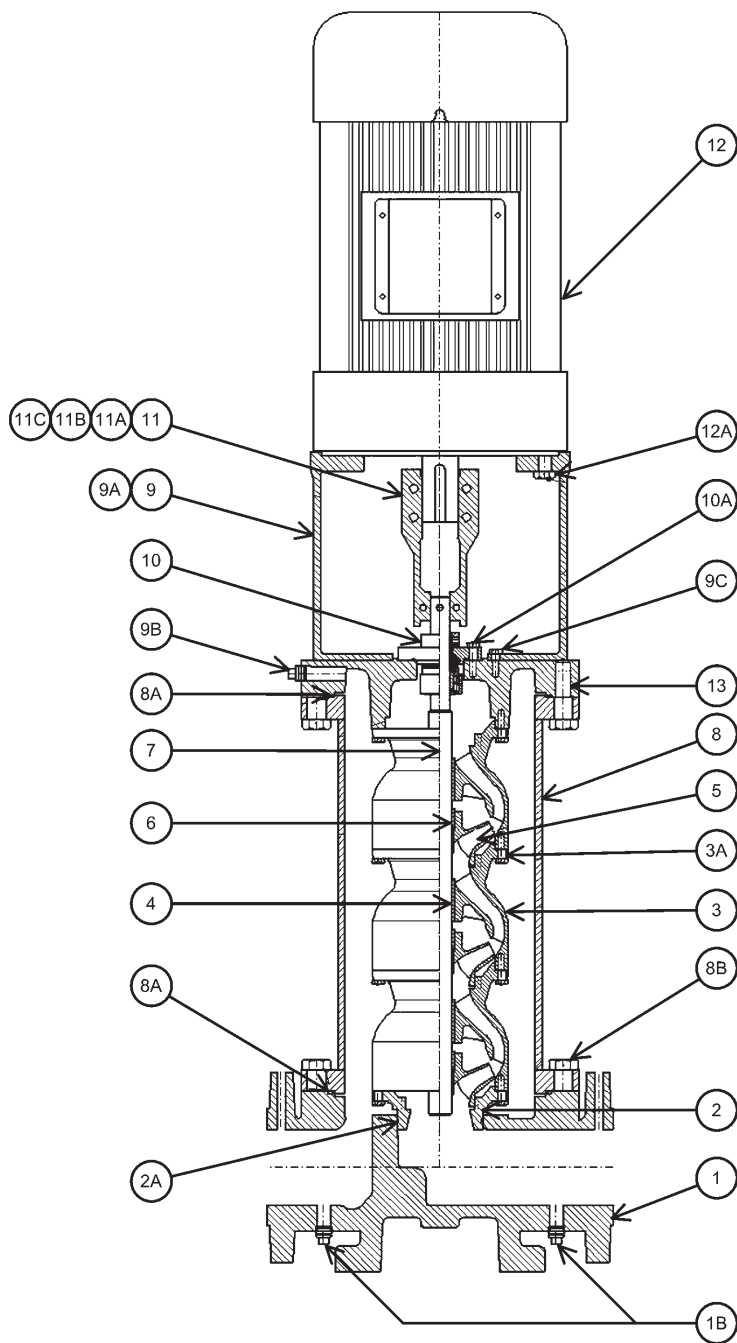

Item No.	Description
1	Pump Body
1B	Pipe Plug - Drain
2	Suction Cover
2A	O-Ring - Suction Cover
3	Intermediate Bowl
3A	Hex Screws - Bowl
4	Bearing
5	Impeller
6	Taperlock
7	Shaft
8	Casing
8A	O-Ring - Casing
8B	Hex Screws - Casing
9	Motor Support
9A	Guard - Motor Support
9B	Pipe Plug
9C	Hex Screws - Motor Support
10	Mechanical Seal
10A	Hex Screws - Seal
11	Coupling
11A	Cap Screws - Coupling
11B	Lock Washers - Coupling
11C	Dowel Pin - Coupling
12	Motor
12A	Hex Screws - Motor
13	Seal Plate

## Turbine

### MODEL: SM1 60 HZ GENERAL PUMP DESCRIPTION

Construction:	Cast iron stainless steel fitted
Capacity:	50 - 225 GPM
Head:	50-880 feet
Staging:	1-8
Minimum flow:	50 GPM
Maximum working pressure:	175 PSI with ANSI Class 125 flange (up to 3 stage) 400 PSI with ANSI Class 250 flange (More than 3 stage)
Temperatures:	Liquid temperature from -13°F (-25°C) to 150°F (65°C)
Solids handling:	Although not recommended, the pump may pass a 1/8" solid.
Piping Connections:	Suction and discharge openings are 3" with ANSI Class 125 or 250 flanges.

Component Description	Material	ASTM Spec.
Motor Support	Cast Iron	A48 Class 30
Shaft Coupling	Cast Iron	A48 Class 30
Mechanical Seal	Type 316SS, Carbon Silicon Carbide	
Seal Cover	Cast Iron	A48 Class 30
Casing	Steel or Type 316SS	A53 Grade A or A312 S31600
Casing and Suction O-ring	Nitrile	D2000 2BG715B14
Pump Shaft	Type 416SS	A582 S41600
Intermediate Bowl	Cast Iron	A48 Class 30
Bowl Bearing	Bronze	B854 C90300
Impeller	Type 316SS	A744 CF8M
Taperlock	Type 316SS	A276 S31600
Suction Cover	Cast Iron	A48 Class 30
Pump Body	Cast Iron	A48 Class 30
Hex Head Capscrew	Steel	SAE J429 Gr. 8
Socket Head Capscrew	Steel	SAE J429 Gr. 8
Washer	Steel	A108 G10180
Pipe Plug	Malleable Iron	A197

### MOTORS

Standard motors supplied by Goulds Water Technology are NEMA standard TC frame motors open drip proof, or totally enclosed fan cooled enclosures. 60 Hz, 2-pole, three phase with 1.15 S.F. For other motor options, contact the factory.

### DIMENSIONS AND WEIGHTS

(All dimensions are in inches, weights are total unit weight.)

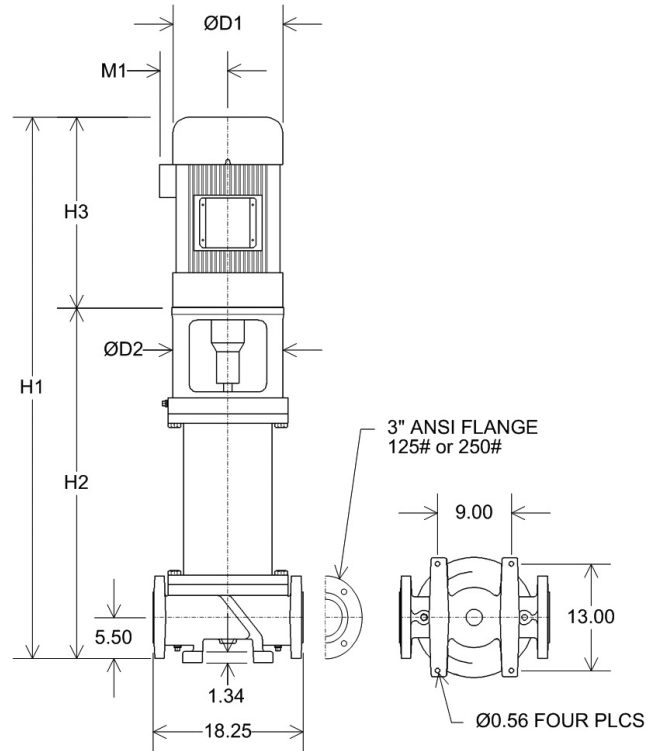

### ODP Motors

Stage	Motor		Dimensions (inches)						Wt. (lbs.)
	Frame	HP	H1	H2	H3	M1	D1	D2	
1	182TC	5	43.25	29.57	13.68	6.87	8.49	13.63	439
2	213TC	10	50.37	35.07	15.30	7.93	10.18	13.63	527
3	215TC	15	55.88	40.57	15.31	7.93	10.18	13.63	593
4	254TC	20	61.44	46.13	15.31	7.93	10.18	13.63	612
5	256TC	25	71.07	51.63	19.44	8.92	11.63	13.63	693
6	284TSC	30	77.69	57.13	20.56	8.94	11.50	13.63	797
7	286TSC	40	85.69	62.69	23.00	12.21	13.25	13.63	952
8	286TSC	40	91.25	68.25	23.00	12.21	13.25	13.63	1000

### TEFC Motors

Stage	Motor		Dimensions (inches)						Wt. (lbs.)
	Frame	HP	H1	H2	H3	M1	D1	D2	
1	184TC	5	44.75	29.57	15.18	6.87	8.60	13.63	439
2	215TC	10	52.07	35.07	17.00	8.05	10.62	13.63	536
3	215TC	15	57.57	40.57	17.00	8.05	10.62	13.63	666
4	256TC	20	68.1	46.13	21.97	10.04	12.94	13.63	687
5	284TSC	25	77.32	51.63	25.69	13.11	15.56	13.63	886
6	286TSC	30	82.82	57.13	25.69	13.11	15.56	13.63	965
7	286TSC	40	88.38	62.69	25.69	13.11	15.56	13.63	1138
8	286TSC	40	93.94	68.25	25.69	13.11	15.56	13.63	1154

Motor dimensions are based on Goulds Water Technology's choice of motors. Other manufacturer's motor may have different dimensions.

## SM1 60 HZ PERFORMANCE CURVE 3500 RPM

CI/SS Construction

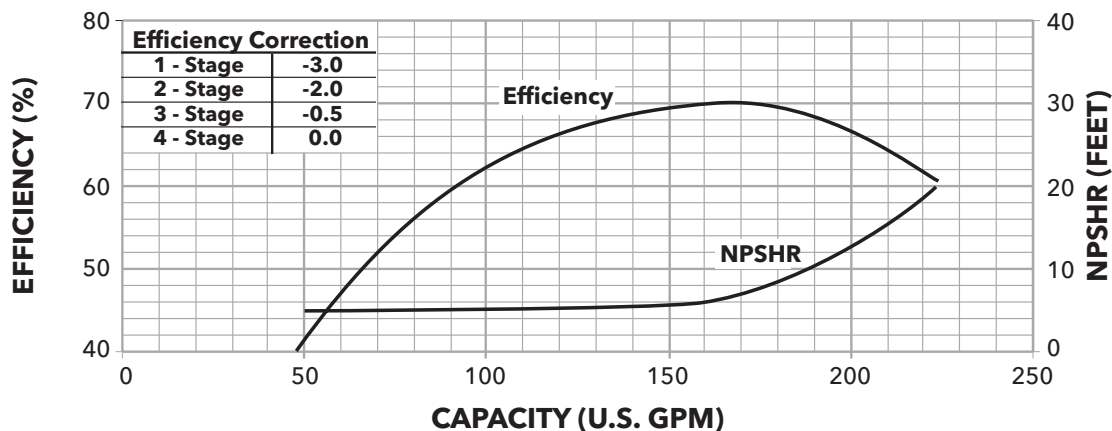
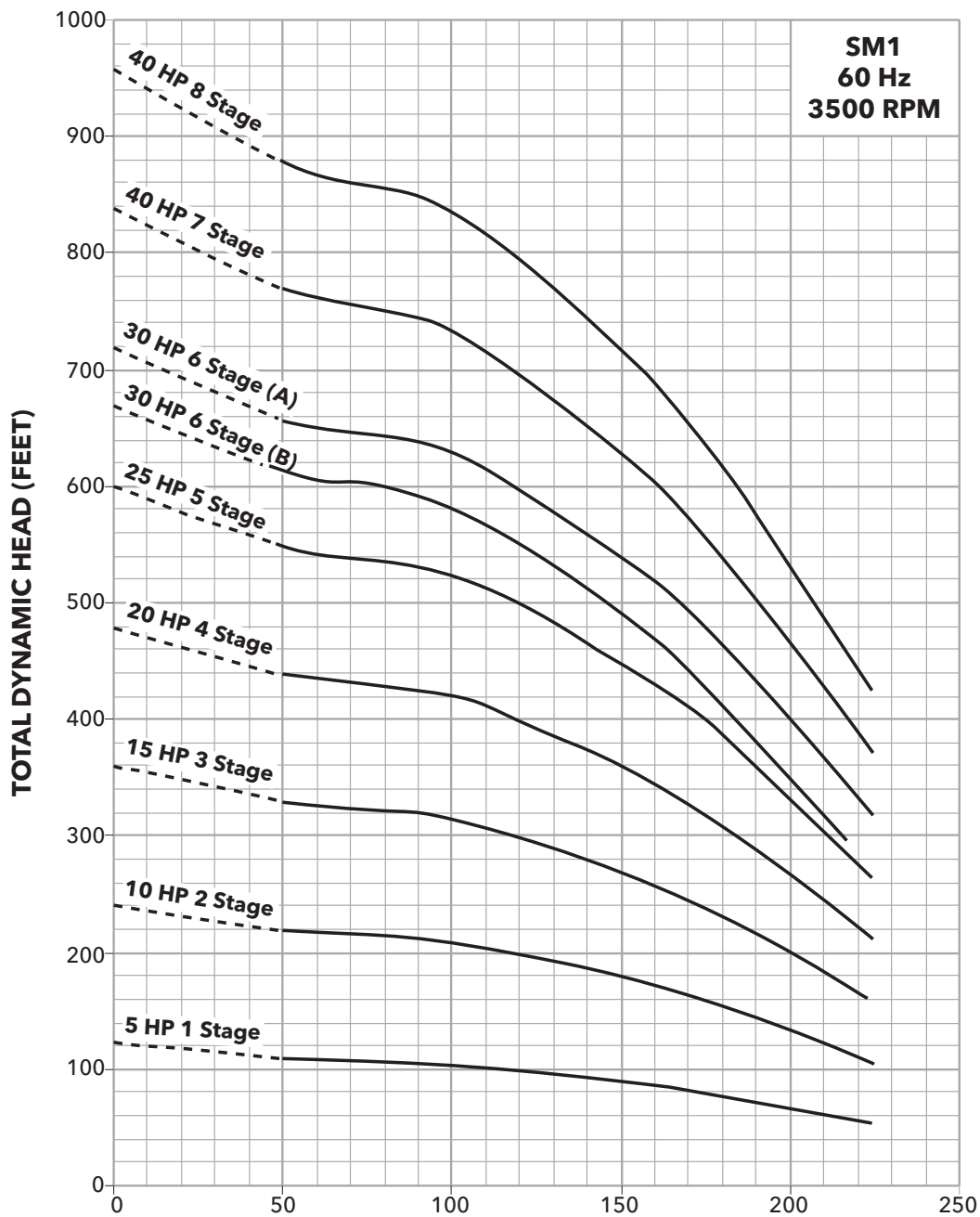

### MODEL: SM2 60 HZ GENERAL PUMP DESCRIPTION

Construction:	Cast iron stainless steel fitted
Capacity:	50 - 300 GPM
Head:	80-880 feet
Staging:	1-7
Minimum flow:	50 GPM
Maximum working pressure:	175 PSI with ANSI Class 125 flange (up to 3 stage) 400 PSI with ANSI Class 250 flange (More than 3 stage)
Temperatures:	Liquid temperature from -13°F (-25°C) to 150°F (65°C)
Solids handling:	Although not recommended, the pump may pass a ¼" solid.
Piping Connections:	Suction and discharge openings are 3" with ANSI Class 125 or 250 flanges.

Component Description	Material	ASTM Spec.
Motor Support	Cast Iron	A48 Class 30
Shaft Coupling	Cast Iron	A48 Class 30
Mechanical Seal	Type 316SS, Carbon Silicon Carbide	
Seal Cover	Cast Iron	A48 Class 30
Casing	Steel or Type 316SS	A53 Grade A or A312 S31600
Casing and Suction O-ring	Nitrile	D2000 2BG715B14
Pump Shaft	Type 416SS	A582 S41600
Intermediate Bowl	Cast Iron	A48 Class 30
Bowl Bearing	Bronze	B854 C90300
Impeller	Type 316SS	A744 CF8M
Taperlock	Type 316SS	A276 S31600
Suction Cover	Cast Iron	A48 Class 30
Pump Body	Cast Iron	A48 Class 30
Hex Head Capscrew	Steel	SAE J429 Gr. 8
Socket Head Capscrew	Steel	SAE J429 Gr. 8
Washer	Steel	A108 G10180
Pipe Plug	Malleable Iron	A197

### MOTORS

Standard motors supplied by Goulds Water Technology are NEMA standard TC frame motors open drip proof, or totally enclosed fan cooled enclosures. 60 Hz, 2-pole, three phase with 1.15 S.F. For other motor options, contact the factory.

### DIMENSIONS AND WEIGHTS

(All dimensions are in inches, weights are total unit weight.)

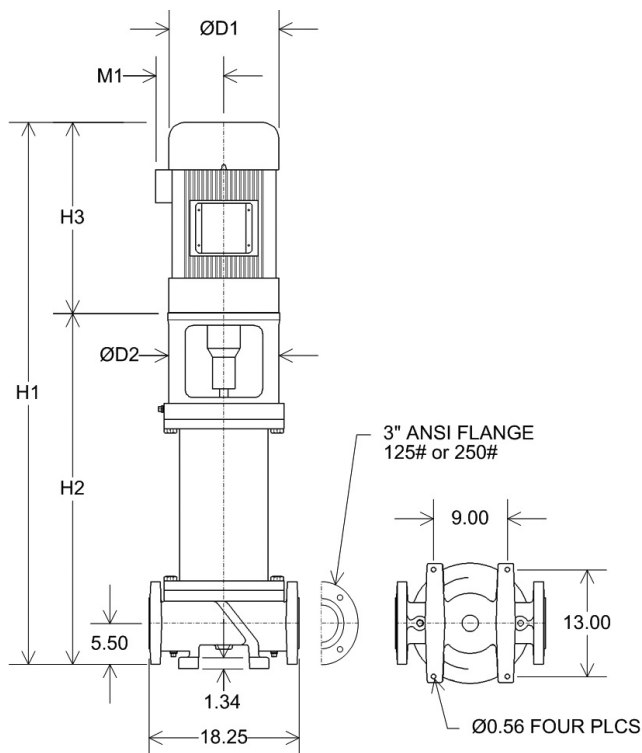

### ODP Motors

Stage	Motor		Dimensions (inches)						Wt. (lbs.)
	Frame	HP	H1	H2	H3	M1	D1	D2	
1	184TC	7.5	43.25	29.57	13.68	6.87	8.94	13.63	445
2	215TC	15	50.38	35.07	15.31	7.93	10.18	13.63	545
3	254TC	20	55.88	40.57	15.31	7.93	10.18	13.63	612
3	256TC	25	60.01	40.57	19.44	8.92	11.63	13.63	645
4	256TC	25	65.57	46.13	19.44	8.92	11.63	13.63	692
4	284TSC	30	66.69	46.13	20.56	8.94	11.50	13.63	750
5	284TSC	30	72.19	51.63	20.56	8.94	11.50	13.63	797
5	286TSC	40	74.63	51.63	23.00	12.21	13.25	13.63	857
6	286TSC	40	80.13	57.13	23.00	12.21	13.25	13.63	904
6	286TSC	50	80.13	57.13	23.00	12.21	13.25	13.63	997
7	286TSC	50	85.69	62.69	23.00	12.21	13.25	13.63	1044

### TEFC Motors

Stage	Motor		Dimensions (inches)						Wt. (lbs.)
	Frame	HP	H1	H2	H3	M1	D1	D2	
1	184TC	7.5	44.75	29.57	15.18	8.05	10.62	13.63	469
2	215TC	15	52.07	35.07	17.00	8.05	10.62	13.63	618
3	256TC	20	62.54	40.57	21.97	10.04	12.94	13.63	687
3	284TSC	25	66.26	40.57	25.69	13.11	15.56	13.63	871
4	284TSC	25	71.82	46.13	25.69	13.11	15.56	13.63	918
4	286TSC	30	71.82	46.13	25.69	13.11	15.56	13.63	918
5	286TSC	30	77.32	51.63	25.69	13.11	15.56	13.63	965
5	286TSC	40	77.32	51.63	25.69	13.11	15.56	13.63	1043
6	286TSC	40	82.82	57.13	25.69	13.11	15.56	13.63	1090
6	326TSC	50	84.92	57.13	27.79	14.12	17.35	13.63	1205
7	326TSC	50	90.48	62.69	27.79	14.12	17.35	13.63	1252

Motor dimensions are based on Goulds Water Technology's choice motors. Other manufacturer's motor may have different dimensions.

## SM2 60 HZ PERFORMANCE CURVE 3500 RPM

CI/SS Construction

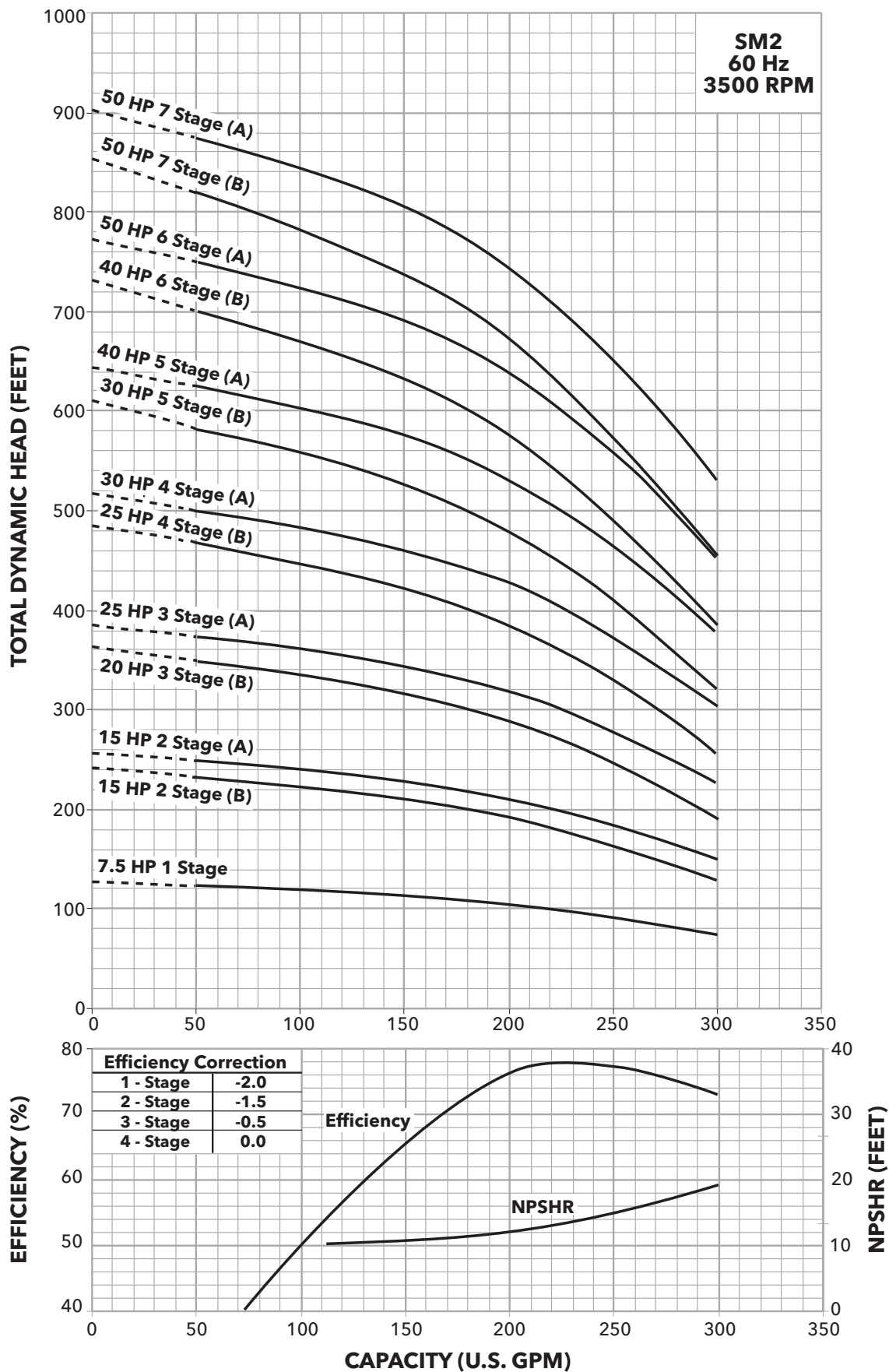

## Turbine

### MODEL: SM3 60 HZ GENERAL PUMP DESCRIPTION

Construction:	Cast iron stainless steel fitted
Capacity:	100 - 500 GPM
Head:	60-750 feet
Staging:	1-6
Minimum flow:	100 GPM
Maximum working pressure:	175 PSI with ANSI Class 125 flange (up to 3 stage) 400 PSI with ANSI Class 250 flange (More than 3 stage)
Temperatures:	Liquid temperature from -13°F (-25°C) to 150°F (65°C)
Solids handling:	Although not recommended, the pump may pass a 3/8" solid.
Piping Connections:	Suction and discharge openings are 4" with ANSI Class 125 or 250 flanges.

Component Description	Material	ASTM Spec.
Motor Support	Cast Iron	A48 Class 30
Shaft Coupling	Cast Iron	A48 Class 30
Mechanical Seal	Type 316SS, Carbon Silicon Carbide	
Seal Cover	Cast Iron	A48 Class 30
Casing	Steel or Type 316SS	A53 Grade A or A312 S31600
Casing and Suction O-ring	Nitrile	D2000 2BG715B14
Pump Shaft	Type 416SS	A582 S41600
Intermediate Bowl	Cast Iron	A48 Class 30
Bowl Bearing	Bronze	B854 C90300
Impeller	Type 316SS	A744 CF8M
Taperlock	Type 316SS	A276 S31600
Suction Cover	Cast Iron	A48 Class 30
Pump Body	Cast Iron	A48 Class 30
Hex Head Capscrew	Steel	SAE J429 Gr. 8
Socket Head Capscrew	Steel	SAE J429 Gr. 8
Washer	Steel	A108 G10180
Pipe Plug	Malleable Iron	A197

### MOTORS

Standard motors supplied by Goulds Water Technology are NEMA standard TC frame motors open drip proof, or totally enclosed fan cooled enclosures. 60 Hz, 2-pole, three phase with 1.15 S.F. For other motor options, contact the factory.

### DIMENSIONS AND WEIGHTS

(All dimensions are in inches, weights are total unit weight.)

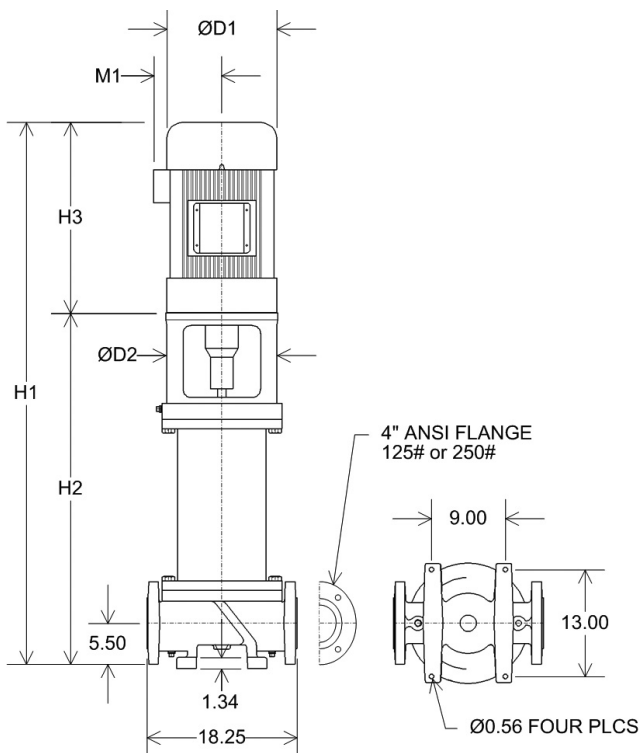

### ODP Motors

Stage	Motor		Dimensions (inches)						Wt. (lbs.)
	Frame	HP	H1	H2	H3	M1	D1	D2	
1	215TC	15	46.50	31.19	15.31	7.93	10.18	13.63	505
2	215TC	15	53.63	38.32	15.31	7.93	10.18	13.63	560
2	254TC	20	53.63	38.32	15.31	7.93	10.18	13.63	578
3	256TC	25	64.81	45.37	19.44	8.92	11.63	13.63	689
3	284TSC	30	65.93	45.37	20.56	8.94	11.50	13.63	722
4	286TSC	50	75.44	52.44	23.00	12.21	13.25	13.63	928
5	326TSC	60	82.07	59.57	22.50	12.21	13.75	13.63	990
6	364TSC	75	95.19	66.69	28.50	12.21	13.75	13.63	1207

### TEFC Motors

Stage	Motor		Dimensions (inches)						Wt. (lbs.)
	Frame	HP	H1	H2	H3	M1	D1	D2	
1	215TC	15	48.19	31.19	17.00	8.05	10.62	13.63	578
2	215TC	15	35.32	38.32	17.00	8.05	10.62	13.63	626
2	256TC	20	60.29	38.32	21.97	10.04	12.94	13.63	653
3	284TSC	25	71.06	45.37	25.69	13.11	15.56	13.63	890
3	286TSC	30	71.06	45.37	25.69	13.11	15.56	13.63	968
4	326TSC	50	80.23	52.44	27.79	14.12	17.35	13.63	1136
5	364TSC	60	90.11	59.57	30.54	14.95	19.25	13.63	1330
6	365TSC	75	97.49	66.69	30.80	14.95	19.25	13.63	1477

Motor dimensions are based on Goulds Water Technology's choice motors. Other manufacturer's motor may have different dimensions.



## SM3 60 HZ PERFORMANCE CURVE 3500 RPM

CI/SS Construction

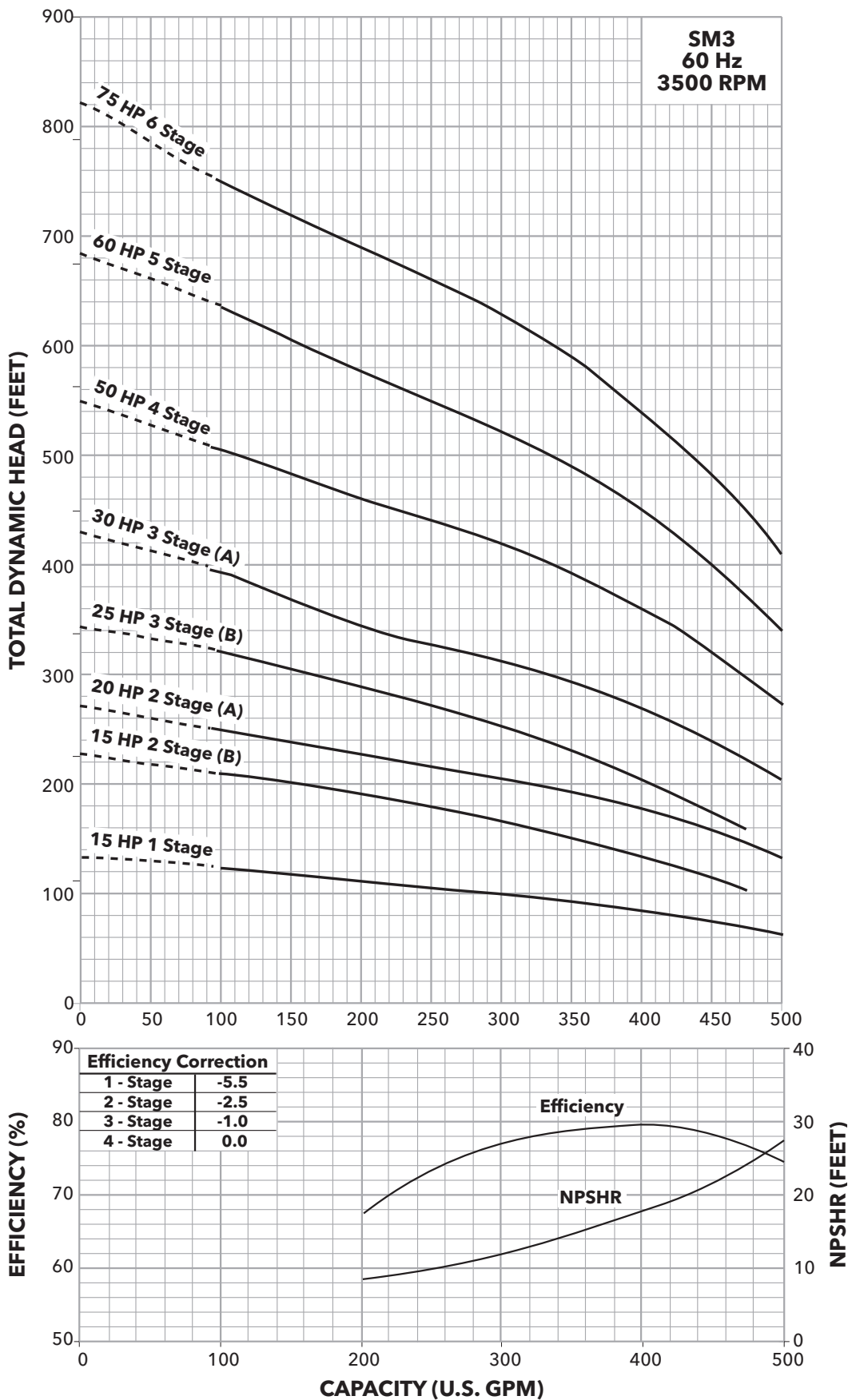

### MODEL: SM4 60 HZ GENERAL PUMP DESCRIPTION

Construction:	Cast iron stainless steel fitted
Capacity:	200 - 600 GPM
Head:	70-520 feet
Staging:	1-4
Minimum flow:	200 GPM
Maximum working pressure:	175 PSI with ANSI Class 125 flange (up to 3 stage) 400 PSI with ANSI Class 250 flange (4 stage)
Temperatures:	Liquid temperature from -13°F (-25°C) to 150°F (65°C)
Solids handling:	Although not recommended, the pump may pass a 3/8" solid.
Piping Connections:	Suction and discharge openings are 4" with ANSI Class 125 or 250 flanges.

Component Description	Material	ASTM Spec.
Motor Support	Cast Iron	A48 Class 30
Shaft Coupling	Cast Iron	A48 Class 30
Mechanical Seal	Type 316SS, Carbon Silicon Carbide	
Seal Cover	Cast Iron	A48 Class 30
Casing	Steel or Type 316SS	A53 Grade A or A312 S31600
Casing and Suction O-ring	Nitrile	D2000 2BG715B14
Pump Shaft	Type 416SS	A582 S41600
Intermediate Bowl	Cast Iron	A48 Class 30
Bowl Bearing	Bronze	B854 C90300
Impeller	Type 316SS	A744 CF8M
Taperlock	Type 316SS	A276 S31600
Suction Cover	Cast Iron	A48 Class 30
Pump Body	Cast Iron	A48 Class 30
Hex Head Capscrew	Steel	SAE J429 Gr. 8
Socket Head Capscrew	Steel	SAE J429 Gr. 8
Washer	Steel	A108 G10180
Pipe Plug	Malleable Iron	A197

### MOTORS

Standard motors supplied by Goulds Water Technology are NEMA standard TC frame motors open drip proof, or totally enclosed fan cooled enclosures. 60 Hz, 2-pole, three phase with 1.15 S.F. For other motor options, contact the factory.

### DIMENSIONS AND WEIGHTS

(All dimensions are in inches, weights are total unit weight.)

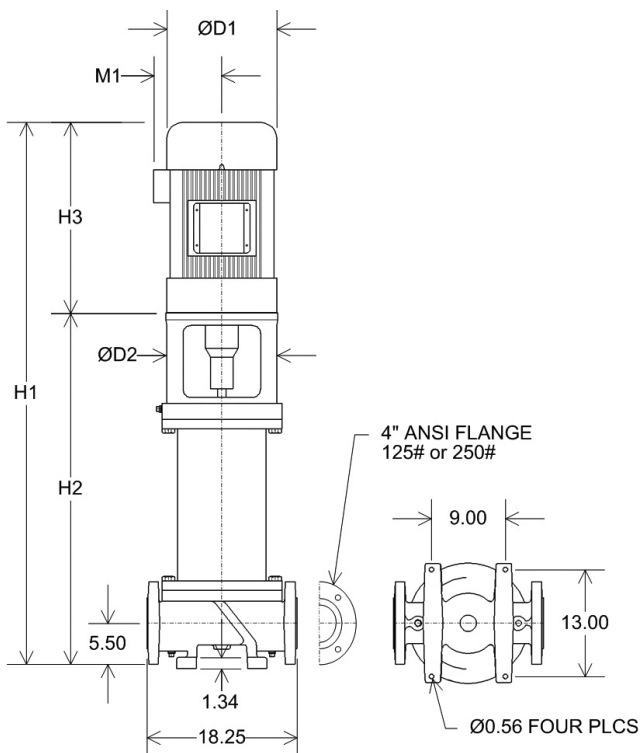

### ODP Motors

Stage	Motor		Dimensions (inches)						Wt. (lbs.)
	Frame	HP	H1	H2	H3	M1	D1	D2	
1	215TC	15	45.75	30.44	15.31	7.93	10.18	13.63	499
1	254TC	20	45.75	30.44	15.31	7.93	10.18	13.63	518
2	256TC	25	56.26	36.82	19.44	8.92	11.63	13.63	600
2	284TSC	30	57.38	36.82	20.56	8.94	11.50	13.63	657
2	286TSC	40	65.26	36.82	23.00	12.21	13.25	13.63	717
3	286TSC	40	66.22	43.22	23.00	12.21	13.25	13.63	765
3	286TSC	50	66.215	43.22	23.00	12.21	13.25	13.63	857
3	326TSC	60	71.07	43.22	22.50	12.21	13.75	13.63	865
4	364TSC	75	78.13	49.63	28.50	12.21	19.25	13.63	1024

### TEFC Motors

Stage	Motor		Dimensions (inches)						Wt. (lbs.)
	Frame	HP	H1	H2	H3	M1	D1	D2	
1	215TC	15	47.44	30.44	17.00	8.05	10.62	13.63	572
1	256TC	20	52.41	30.44	21.97	10.04	12.94	13.63	593
2	284TSC	25	62.51	36.82	25.69	13.11	15.56	13.63	793
2	286TSC	30	62.51	36.82	25.69	13.11	15.56	13.63	825
2	286TSC	40	67.95	36.82	25.69	13.11	15.56	13.63	903
3	286TSC	40	68.91	43.22	25.69	13.11	15.56	13.63	951
3	326TSC	50	71.01	43.22	27.79	14.12	17.35	13.63	1065
3	364TSC	60	79.11	43.22	30.54	14.95	19.25	13.63	1205
4	365TSC	75	80.43	49.63	30.80	14.95	19.25	13.63	1294

Motor dimensions are based on Goulds Water Technology's choice motors. Other manufacturer's motor may have different dimensions.

## SM4 60 HZ PERFORMANCE CURVE 3500 RPM

CI/SS Construction

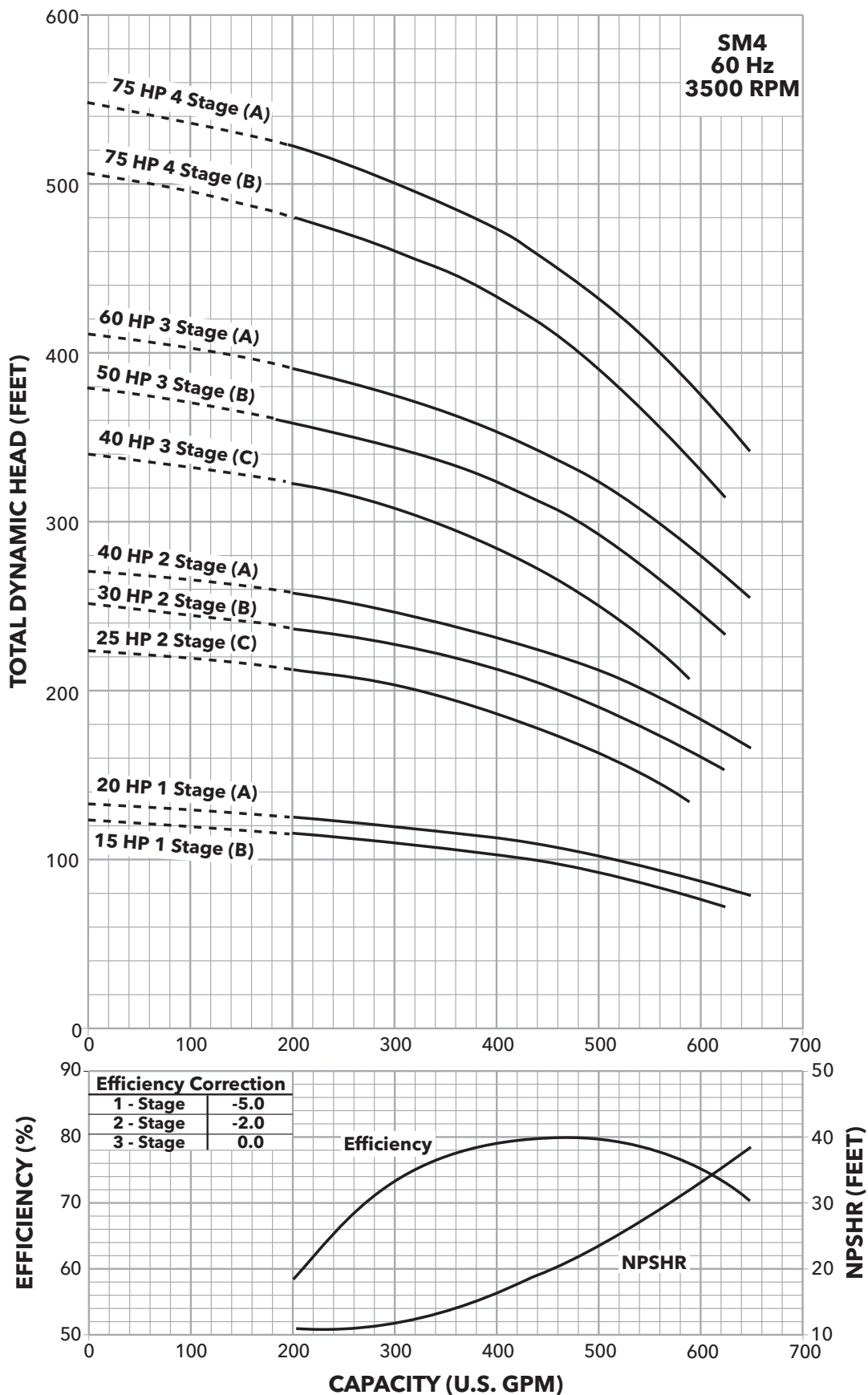

### MODEL: SM5 60 HZ GENERAL PUMP DESCRIPTION

Construction:	Cast iron stainless steel fitted
Capacity:	200 - 700 GPM
Head:	40-600 feet
Staging:	1-6
Minimum flow:	200 GPM
Maximum working pressure:	175 PSI with ANSI Class 125 flange (up to 4 stage) 400 PSI with ANSI Class 250 flange (5 and 6 stage)
Temperatures:	Liquid temperature from -13°F (-25°C) to 150°F (65°C)
Solids handling:	Although not recommended, the pump may pass a ½" solid.
Piping Connections:	Suction and discharge openings are 4" with ANSI Class 125 or 250 flanges.

Component Description	Material	ASTM Spec.
Motor Support	Cast Iron	A48 Class 30
Shaft Coupling	Cast Iron	A48 Class 30
Mechanical Seal	Type 316SS, Carbon Silicon Carbide	
Seal Cover	Cast Iron	A48 Class 30
Casing	Steel or Type 316SS	A53 Grade A or A312 S31600
Casing and Suction O-ring	Nitrile	D2000 2BG715B14
Pump Shaft	Type 416SS	A582 S41600
Intermediate Bowl	Cast Iron	A48 Class 30
Bowl Bearing	Bronze	B854 C90300
Impeller	Type 316SS	A744 CF8M
Taperlock	Type 316SS	A276 S31600
Suction Cover	Cast Iron	A48 Class 30
Pump Body	Cast Iron	A48 Class 30
Hex Head Capscrew	Steel	SAE J429 Gr. 8
Socket Head Capscrew	Steel	SAE J429 Gr. 8
Washer	Steel	A108 G10180
Pipe Plug	Malleable Iron	A197

### MOTORS

Standard motors supplied by Goulds Water Technology are NEMA standard TC frame motors open drip proof, or totally enclosed fan cooled enclosures. 60 Hz, 2-pole, three phase with 1.15 S.F. For other motor options, contact the factory.

### DIMENSIONS AND WEIGHTS

(All dimensions are in inches, weights are total unit weight.)

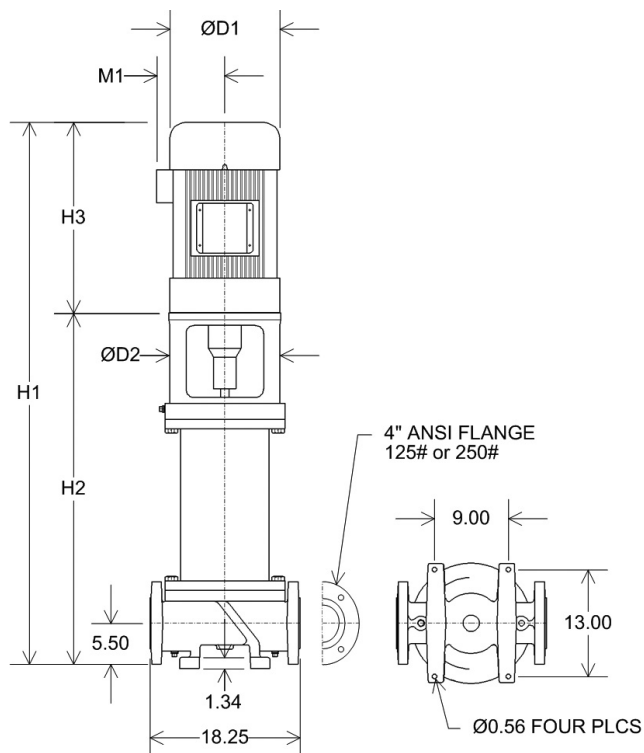

### ODP Motors

Stage	Motor		Dimensions (inches)						Wt. (lbs.)
	Frame	HP	H1	H2	H3	M1	D1	D2	
1	213TC	10	46.49	31.19	15.30	7.93	10.18	13.63	487
1	215TC	15	46.50	31.19	15.31	7.93	10.18	13.63	505
2	254TC	20	53.63	38.32	15.31	7.93	10.18	13.63	578
2	256TC	25	57.76	38.32	19.44	8.92	11.63	13.63	611
3	284TSC	30	65.93	45.37	20.56	8.94	11.50	13.63	722
3	286TSC	40	68.37	45.37	23.00	12.21	13.25	13.63	782
4	286TSC	40	75.44	52.44	23.00	12.21	13.25	13.63	836
4	286TSC	50	75.44	52.44	23.00	12.21	13.25	13.63	928
5	326TSC	60	82.06	59.56	22.50	12.21	13.75	13.63	1082
6	364TSC	75	95.19	66.69	28.50	12.21	19.25	13.63	1207

### TEFC Motors

Stage	Motor		Dimensions (inches)						Wt. (lbs.)
	Frame	HP	H1	H2	H3	M1	D1	D2	
1	215TC	10	48.19	31.19	17.00	8.05	10.62	13.63	496
1	215TC	15	48.19	31.19	17.00	8.05	10.62	13.63	578
2	256TC	20	60.29	38.32	21.97	10.04	12.94	13.63	653
2	284TSC	25	64.01	38.32	25.69	13.11	15.56	13.63	804
3	286TSC	30	71.06	45.37	25.69	13.11	15.56	13.63	890
3	286TSC	40	71.06	45.37	25.69	13.11	15.56	13.63	968
4	286TSC	40	78.13	52.44	25.69	13.11	15.56	13.63	1022
4	326TSC	50	80.23	52.44	27.79	14.12	17.35	13.63	1136
5	364TSC	60	90.36	59.56	30.80	14.95	19.25	13.63	1330
6	365TSC	75	97.49	66.69	30.80	14.95	19.25	13.63	1477

Motor dimensions are based on Goulds Water Technology's choice motors. Other manufacturer's motor may have different dimensions.

## SM5 60 HZ PERFORMANCE CURVE 3500 RPM

CI/SS Construction

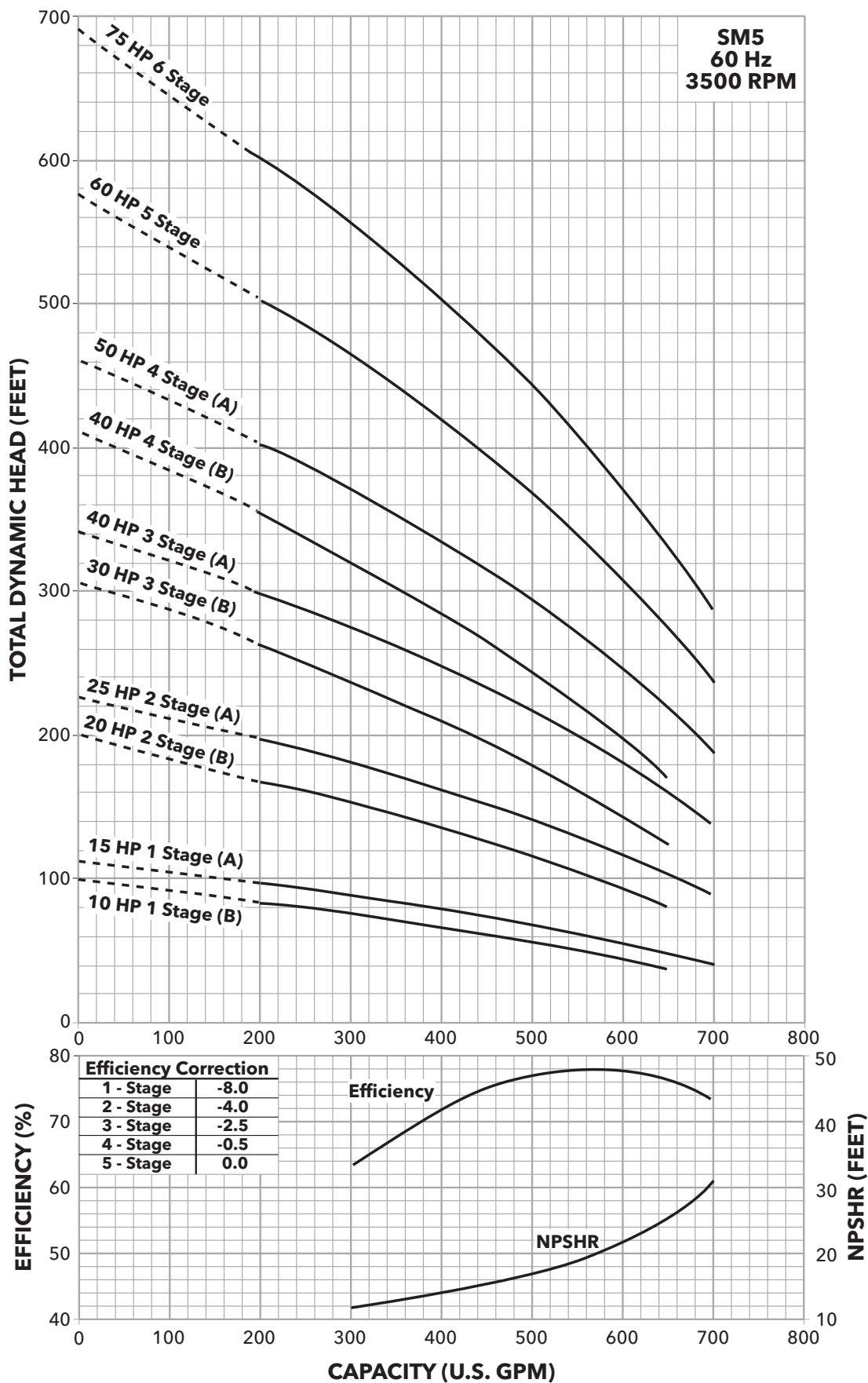

## Turbine

### MODEL: SM6 60 HZ GENERAL PUMP DESCRIPTION

Construction:	Cast iron stainless steel fitted
Capacity:	200 - 850 GPM
Head:	50-400 feet
Staging:	1-4
Minimum flow:	200 GPM
Maximum working pressure:	175 PSI with ANSI Class 125 flange
Temperatures:	Liquid temperature from -13°F (-25°C) to 150°F (65°C)
Solids handling:	Although not recommended, the pump may pass a ½" solid.
Piping Connections:	Suction and discharge openings are 4" with ANSI Class 125 or 250 flanges.

Component Description	Material	ASTM Spec.
Motor Support	Cast Iron	A48 Class 30
Shaft Coupling	Cast Iron	A48 Class 30
Mechanical Seal	Type 316SS, Carbon Silicon Carbide	
Seal Cover	Cast Iron	A48 Class 30
Casing	Steel or Type 316SS	A53 Grade A or A312 S31600
Casing and Suction O-ring	Nitrile	D2000 2BG715B14
Pump Shaft	Type 416SS	A582 S41600
Intermediate Bowl	Cast Iron	A48 Class 30
Bowl Bearing	Bronze	B854 C90300
Impeller	Type 316SS	A744 CF8M
Taperlock	Type 316SS	A276 S31600
Suction Cover	Cast Iron	A48 Class 30
Pump Body	Cast Iron	A48 Class 30
Hex Head Capscrew	Steel	SAE J429 Gr. 8
Socket Head Capscrew	Steel	SAE J429 Gr. 8
Washer	Steel	A108 G10180
Pipe Plug	Malleable Iron	A197

### MOTORS

Standard motors supplied by Goulds Water Technology are NEMA standard TC frame motors open drip proof, or totally enclosed fan cooled enclosures. 60 Hz, 2-pole, three phase with 1.15 S.F. For other motor options, contact the factory.

### DIMENSIONS AND WEIGHTS

(All dimensions are in inches, weights are total unit weight.)

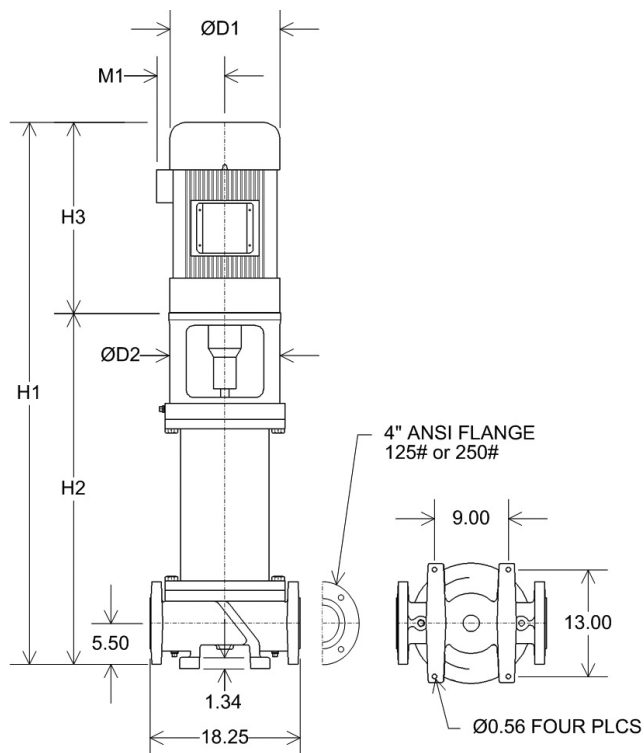

### ODP Motors

Stage	Motor		Dimensions (inches)						Wt. (lbs.)
	Frame	HP	H1	H2	H3	M1	D1	D2	
1	215TC	15	46.50	31.19	15.31	7.93	10.18	13.63	505
2	256TC	25	57.76	38.32	19.44	8.92	11.63	13.63	611
2	284TSC	30	58.88	38.32	20.56	8.94	11.50	13.63	668
3	286TSC	40	68.37	45.37	23.00	12.21	13.25	13.63	782
3	286TSC	50	68.37	45.37	23.00	12.21	13.25	13.63	874
4	326TSC	60	74.94	52.44	22.50	12.21	13.75	13.63	936

### TEFC Motors

Stage	Motor		Dimensions (inches)						Wt. (lbs.)
	Frame	HP	H1	H2	H3	M1	D1	D2	
1	215TC	15	48.19	31.19	17.00	8.05	10.62	13.63	578
2	284TSC	25	64.01	38.32	25.69	13.11	15.56	13.63	804
2	286TSC	30	64.01	38.32	25.69	13.11	15.56	13.63	836
3	286TSC	40	71.06	45.37	25.69	13.11	15.56	13.63	968
3	326TSC	50	73.16	45.37	27.79	14.12	17.35	13.63	1082
4	364TSC	60	82.98	52.44	30.54	14.95	19.25	13.63	1276

Motor dimensions are based on Goulds Water Technology's choice of motors. Other manufacturer's motor may have different dimensions.

## SM6 60 HZ PERFORMANCE CURVE 3500 RPM

CI/SS Construction

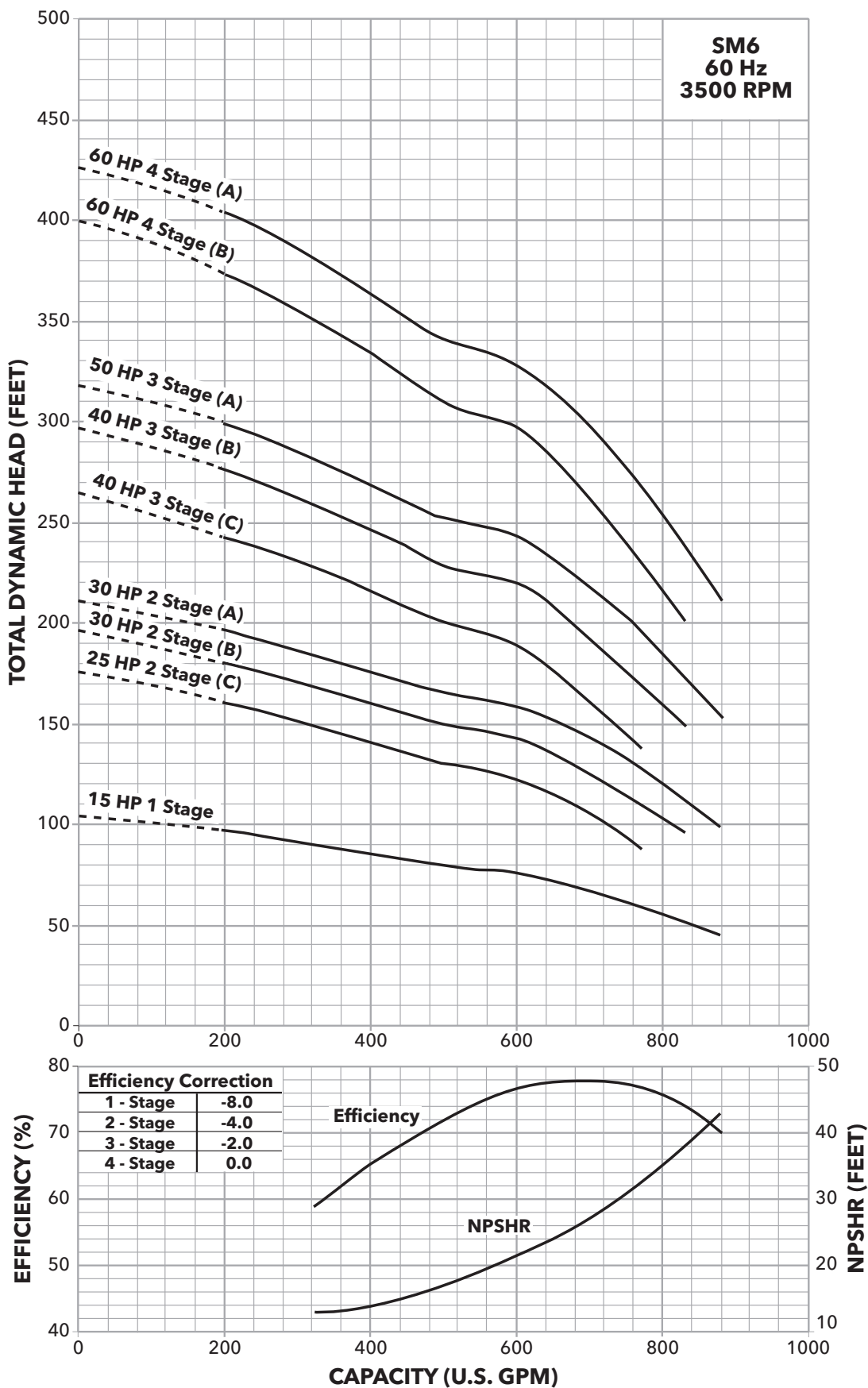

## SMVT FEATURES AND BENEFITS

### All units:

Flow range: 50 GPM through 850 GPM

Heads Range: Up to 880'

Efficiencies: Up to 80%

Proven turbine pump design for high efficiencies and durability

Vertical unit - excellent for limited space installations

Vertical and Horizontal pump offering

Standard Goulds Water Technology turbine parts used, for quicker repair and repair part delivery

Quality John Crane 2B Cartridge Mechanical Seal

Precision balanced rotating elements

Will Pass up to ½" solids depending upon the particular model

Motor available in ODP or TEFC enclosure

Temperature: From -13° F to 150° F for standard construction

### Construction:

*Heavy duty construction for longer service life*

Materials: Standard Cast Iron / Stainless Steel Fitted Construction with bronze bearings  
Optional Stainless Steel casing

### Principal Markets:

Commercial Applications	Booster Units High Rise Building Water Applications HVAC
Municipal Applications	Package Pump Stations, Booster Stations Water Treatment Applications
Irrigation Applications	Turf Irrigation, Golf Courses, Stadiums Nurseries, Greenhouses, Sprinkler Systems



Xylem, Inc.  
P.O. Box 5487  
Lubbock, TX 79408  
Phone: (806) 763-7867  
Fax: (800) 453-4749  
[www.xylem.com/brands/gouldswatertechnology](http://www.xylem.com/brands/gouldswatertechnology)

Goulds is a registered trademark of Goulds Pumps, Inc. and is used under license.  
CentriPro and Aquavar SOLO are trademarks of Xylem Inc. or one of its subsidiaries.  
© 2012 Xylem Inc. BSMVT August 2009