



# Pump Monitor Relay PMR5



UL FILE #E101681

MADE IN THE U.S.A.

## OPERATION

The Pump Monitor Relay provides Motor Over Temperature and Moisture alarms for Submersible Pumps.

**Motor Over Temperature Alarm** - The unit applies a low voltage DC signal to the Motor Thermal Sensor to check its status. If the unit detects that the Motor Thermal Sensor contacts are closed (normal condition), the Overtemp indication remains off, and the Overtemp Relay is energized closing the contacts between terminals 1 and 3.

If the Motor Thermal Sensor contacts open (Over Temperature condition), the Overtemp Indication is turned on and the Overtemp Alarm Relay is de-energized opening the contacts between terminals 1 and 3 and closing the contacts between terminals 1 and 4.

When the High Motor Temperature condition has cleared, the unit will reset based on the position of Alarm Reset Mode Select Switch (Auto or Manual). When in the Auto position, the Overtemp Alarm resets automatically. If the switch is in the Manual position, the Overtemp Reset Push-button must be pushed for approximately 1.5 seconds to clear the alarm.

**Moisture Alarm** - The unit detects moisture inside a pump motor by using a low voltage AC signal to measure the resistance between a single (or dual) Moisture Probe(s) and the grounded motor housing, or across two Moisture Probes. A Motor Moisture condition is considered present when the amount of moisture in the motor chamber(s) being monitored (i.e., seal, lower stator, or connection chamber) causes the resistance between terminal 2 and 5 to drop below the setting on the potentiometer. When this occurs the unit turns on the Moisture Indication and the Moisture Alarm Relay is energized opening the contacts between terminals 11 and 8 and closing the contacts between terminals 11 and 9.

The alarm trip point may be set by the following procedure: Isolate the Moisture Probe(s) from terminal 2. Connect a resistor, with the desired trip value, across terminals 2 and 5. Slowly adjust the potentiometer to the point where the alarm turns on. Remove the resistor and reconnect to the Moisture Probe(s).

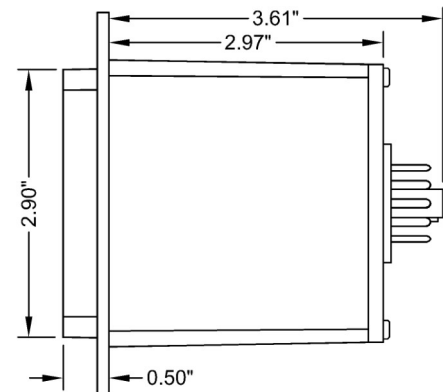
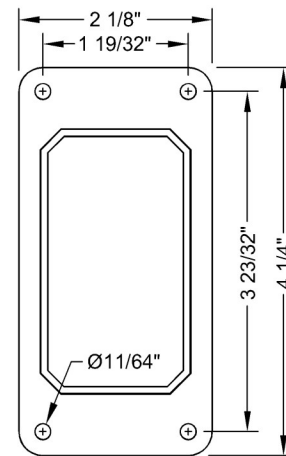

## SPECIFICATIONS

Input Power:	120 VAC ±10%, 7.0 VA max
Output Rating:	8A Resistive @ 120VAC
Operating Temp:	-20°C to +65 °C
Storage Temp:	-45°C to +85 °C
Temp Sensor Voltage:	6.6 VDC ±10%
Moisture Sensor Voltage:	4.7 VAC ±10%
Enclosure:	White Lexan
Base:	Phenolic

## ORDERING INFORMATION

Part Number: GSPMR5

# Pump Monitor Relay PMR5

## CONNECTION DIAGRAMS

### CHECKS RESISTANCE BETWEEN ONE PROBE AND MOTOR HOUSING

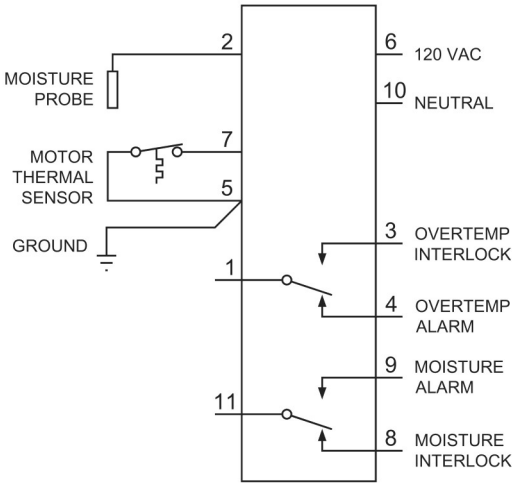

### CHECKS RESISTANCE BETWEEN TWO PROBES AND MOTOR HOUSING

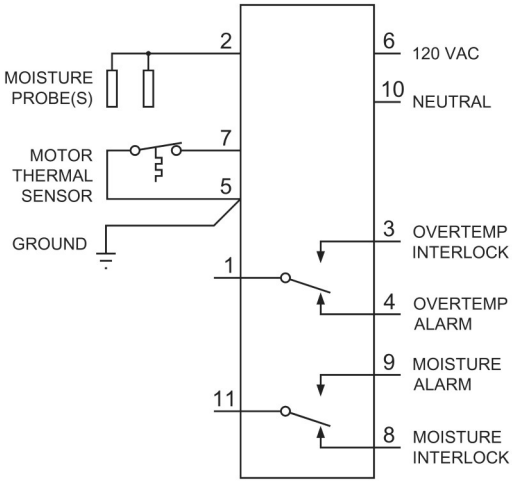

### CHECKS RESISTANCE BETWEEN TWO PROBES

