

HYDROMATIC® HPE CHOPPER PUMP DESTROYS DEBRIS BEFORE IT CLOGS

PATENT-PENDING CHOPPER MECHANISM

- Cuts material into small pieces allowing free flow through the pump

PREMIUM EFFICIENT MOTOR

- Delivers high starting torque for reduced risk of clogging during start-up

SEMI-OPEN IMPELLER DESIGN

- Provides superior solids handling capability while delivering increased efficiency

CUTTING BLADE AND PLATE

- Made from 440 SST hardened to 57-60 Rockwell C for long life
- Replaceable for lower maintenance costs
- Adjustable cutting plate ensures optimal alignment for best cutting performance
- Relief groove on cutter plate creates extra cutting edge and forces debris away from cutting surface for maximum clog resistance



SERRATED BLADES

- For effective cutting without need for re-sharpening.



HYDROMATIC® HPE CHOPPER PUMP

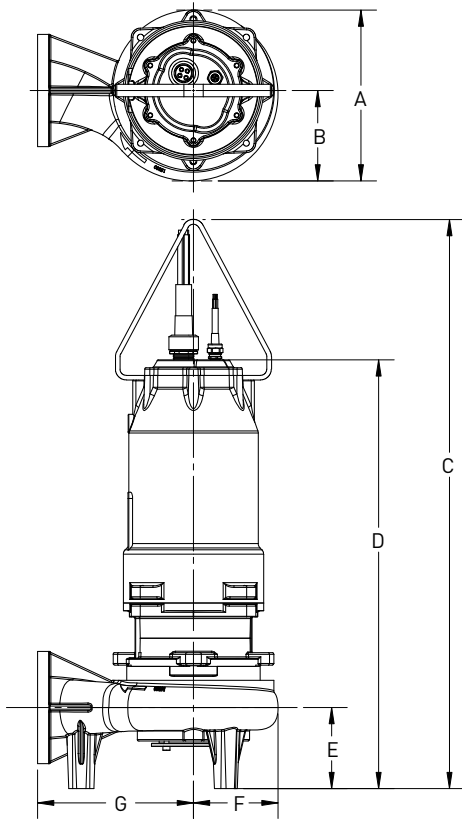

	A	B	C	D	E	F	G
CS4(X)P	13.70	7.25	45.64	34.39	6.50	6.77	12.5

Catalog	Eng. No.	HP	Voltage/Ph	Trim
1150 RPM				
C4SXP300DB	528280197	3	208/3	7.75
C4SXP300EB	528280207	3	230/3	7.75
C4SXP300FB	528280217	3	460/3	7.75
C4SXP300GB	528280227	3	575/3	7.75
C4SXP500DB	528280237	5	208/3	8.75
C4SXP500EB	528280247	5	230/3	8.75
C4SXP500FB	528280257	5	460/3	8.75
C4SXP500GB	528280267	5	575/3	8.75
1750 RPM				
C4SXP750CC	528280067	7.5	230/1	7
C4SXP750DC	528280077	7.5	208/3	7
C4SXP750EC	528280087	7.5	230/3	7
C4SXP750FC	528280097	7.5	460/3	7
C4SXP750GC	528280107	7.5	575/3	7
C4SXP1000DC	528280117	10	208/3	7.75
C4SXP1000EC	528280127	10	230/3	7.75
C4SXP1000FC	528280137	10	460/3	7.75
C4SXP1000GC	528280147	10	575/3	7.75
C4SXP1500DC	528280157	15	208/3	8.75
C4SXP1500EC	528280167	15	230/3	8.75
C4SXP1500FC	528280177	15	460/3	8.75
C4SXP1500GC	528280187	15	575/3	8.75

RPM: 1750 DISCHARGE: 4"

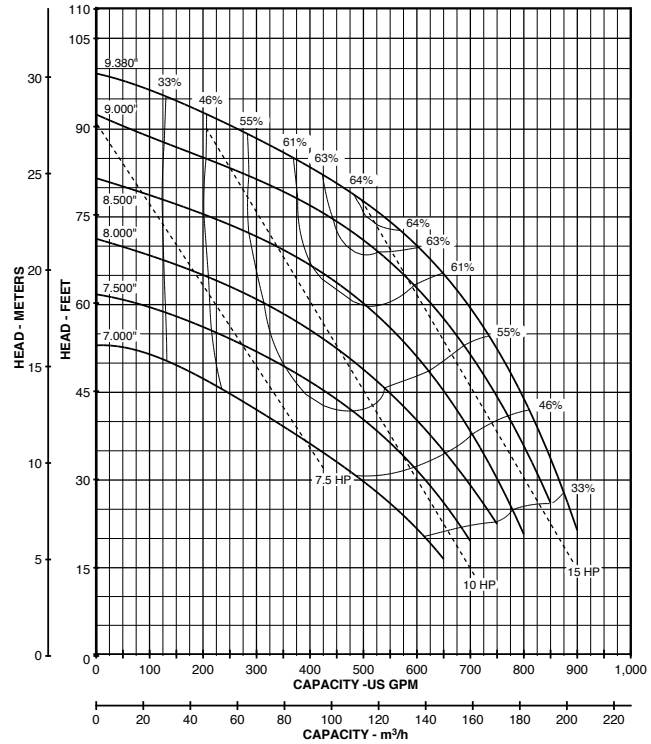

RPM: 1150 DISCHARGE: 4"

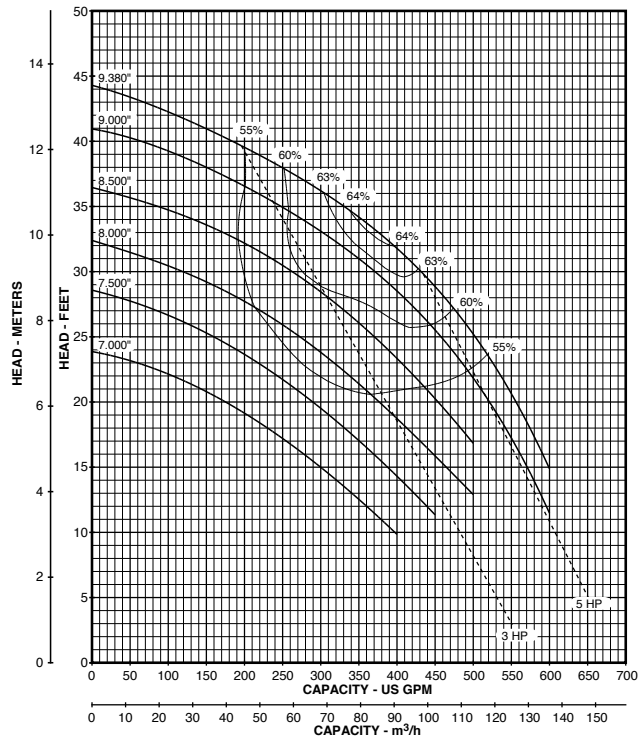

1101 MYERS PARKWAY, ASHLAND, OH 44805 WWW.HYDROMATIC.COM
PH: 855-274-8944

Because we are continuously improving our products and services, Pentair reserves the right to change specifications without prior notice.