

Dosing/Metering Pump



Designed for low flow, metering or dosing applications offering continuous and accurate repeatability.

Typical Applications

- Acids, alkalis
- Sludge dewatering
- Food ingredients
- Brewing, winemaking
- Chemical processing
- Process mining
- Dyes, inks
- Flocculents
- Cosmetics
- Oil well dosing

Capacity

- 2 to 1,250 l/h
- 0.53 to 330 US gal/h

Pressure

- Up to 72 bar
- 1,044 psi

Temperature

- Up to 120°C or 248°F
- (stainless steel models)

Features and Benefits

Gentle Pumping Action

Minimize shear and crush damage to the pumped product. No pulsation or emulsification.

Materials of Construction

All pump components, except the body, coupling rod and suction chamber are supplied in stainless steel. The suction chamber is manufactured in high-density polyethylene. The end cover and mechanical seal housing is PVDF. For severe chemical environments, internal pump components are supplied in Hastelloy.

Handles Gas Entrainment

No air or gas locking in the pump. The positive seal formed by the interference fit between rotor and stator enables the pump to self prime, and it also allows tri-phase liquids i.e. solids, gases, and liquids to be easily handled.

Sealed Joints

Fully sealed drive train to maximize the life of the pump and minimize down time.

Resilient Stator

Flexible in operation and high resistance to wear. Available in a variety of materials allowing a wide range of products to be pumped.

Robust Drives

Specially selected drives and gearboxes for longer life. Options include fixed or variable speed drives with mechanical variable speed or frequency inverter.

Interchangeable Components

A number of Dosing Pump parts are interchangeable with the small Compact C Pump reducing stocked inventory.

Flow Meter

Available as an option for flow or temperature monitoring.

Dosing/Metering Pump

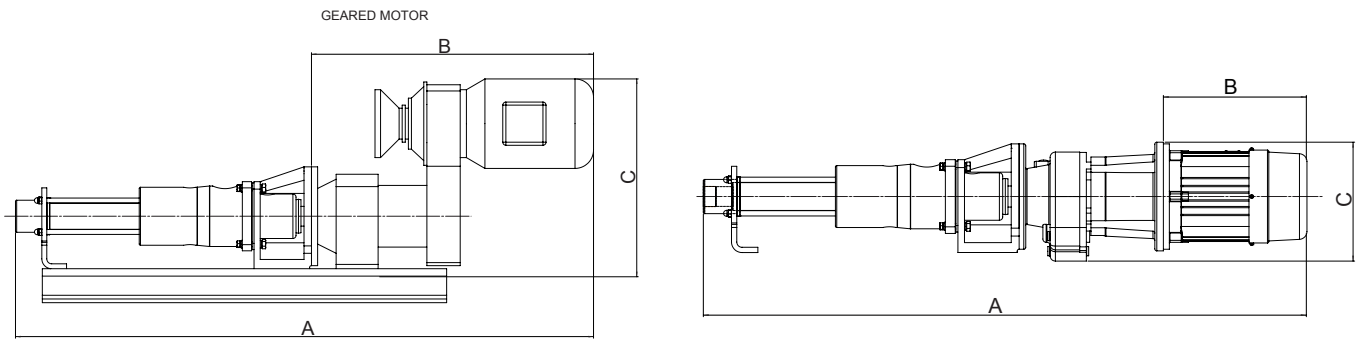

Performance

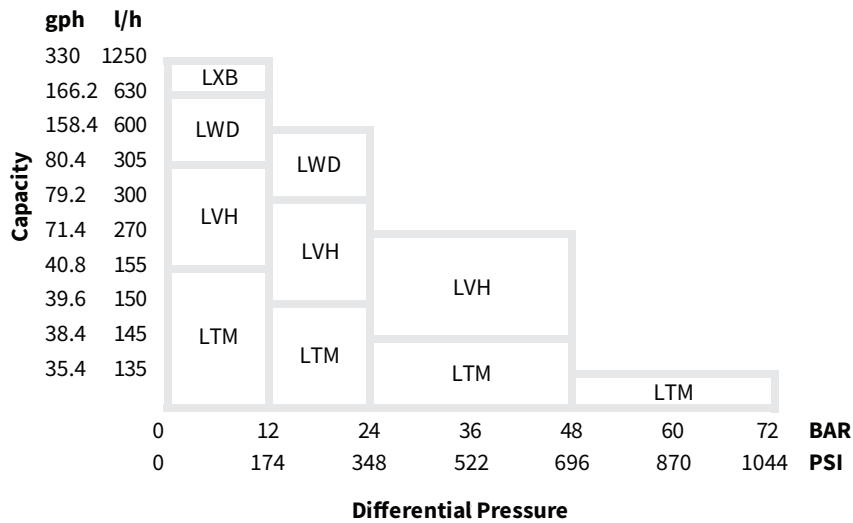

Dimensions

Drive Variation	Pump Model	Power		Ref	A		B		C	
		kW	Hp		mm	Inches	mm	Inches	mm	Inches
Geared Motor	LXB	0.37	0.50	DA	803	31.6	323	12.7	168	6.6
	LWD									
	LVH	0.55	0.74	DA	940	37.0	340	13.4	178	7.0
	LTM									
	LVH	0.37	0.50	DB	863	33.9	323	12.7	168	6.6
	LTM									
	LVH	1.1	1.47	DY	932	36.7	332	13.1	225	8.8
	LTM									
	LTM									
	Variable Speed	LXB	0.37	0.50	EA/EC	937	36.8	457	17.9	306
LWD										
LVH										
LTM										
LXB		0.55	0.74	EB/ED	937	36.9	457	17.9	306	12.0
LWD										
LVH										
LTM										

Model	Pump Weight Kg (lb)
	Motorized
LTM	15 Kg (33lb)
LVH	
LWD	
LXB	

Weights are for guidance only. Please contact NOV for further assistance.

All dimensions are for guidance only. For more information, please contact NOV.

