

LIQUID LEVEL CONTROL

SANDPIPER
ACCESSORIES



II 2 G D T5



032.036.000

SANDPIPER's float actuated Liquid Level Control unit automatically opens and closes air supply to your pump, bringing the following benefits to your process:



PNEUMATIC

No electrical power required



ADJUSTABLE

Operating range from a few inches to 9 ft (2.7 m)



SIMPLE

Easy to install & operate



VERSATILE

Quick reversible operation



RELIABLE

Stainless Steel float & connecting rod



SAFE

ATEX compliant



UNIVERSAL

Can use with all AODD pumps

HOW IT WORKS

- 1 Float is raised or lowered
- 2 Float rod activates switch
- 3 Pilot valve activated
- 4 Regulator turns air on/off to the pump

COMMON APPLICATIONS



Sumping



Dewatering



Fluid Transfer



Tank Filling

REVERSIBLE OPERATION

Operation can be reversed by installing the top float rod bracket in the opposite direction from position shown.

Standard Operation

High Level = On, Low Level = Off

Reverse Operation

High Level = Off, Low Level = On

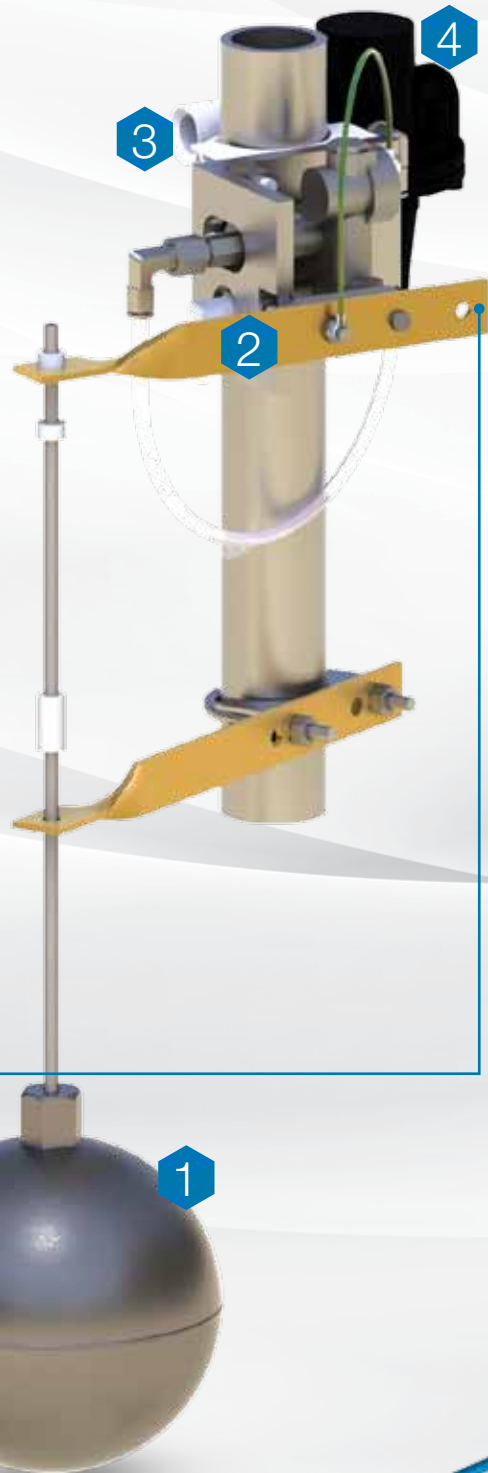

A
C
C
E
S
S
O
R
I
E
S

SANDPIPER
ACCESSORIES

Warren Rupp, Inc.
A Unit of IDEX Corporation
800 North Main Street
Mansfield, OH 44902 USA

Phone: 419.524.8388
Fax: 419.522.7867
sandpiperpump.com



IDEX
CORPORATION

Contact Your Local Distributor to Place Your Order:

©Copyright 2013 Warren Rupp, Inc. All Rights Reserved.

sp_LLC_flyer-rev0713