

VIKING PUMP

A Unit of IDEX Corporation

Viking® Non-Metallic Mag Drive Pumps

*Sealless, Non-Metallic Pumps for
Crucial Liquid Containment Applications*

CMD
COMPOSITE MAG DRIVE

- Universal flanges and Motor Adapters
- Standard housing mates to both DIN and ANSI flange systems
- Standard adapters mate to multiple NEMA and IEC motors



Capacity to 33 GPM (125 LPM)

Pressure to 150 PSI (10 Bar)

Viscosity 28 to 25,000 SSU (0.8 to 5,000 cSt)

Temperature -40°F to +150°F (-40°C to +65°C)

Viking® Reliability in a Sealless, Non-metallic Gear Pump

CMD Mag Drive Series' outer magnets are turned by a motor, and their magnetic force passes through the hermetically sealed canister causing the rotation of the Mag Drive's inner magnets. The inner magnets turn the drive gear shaft, which turns the driven gear, carrying the liquid from the suction to discharge port.

The Viking Advantages

Advanced Durability

Viking's CMD series external gear pump is made of engineered fluoropolymers with superior corrosion resistance and strength over a broad range of chemicals and temperatures. Its sealless design eliminates potential leak points, as well as the eddy current energy loss and heat rise common in metallic pumps. Fully encapsulated, self-aligning magnets use patent pending spline design allowing them to "float" on the drive shaft without inducing axial loads, extending service life.

Ease of Installation

A unique, universal flange design provides easy installation to either ANSI or DIN flanged systems. The close-coupled mounting eliminates traditional alignment issues with pump and motor for quicker, easier installation. The CMD Series' modular design of magnet hub provides one drive magnet per pump size, with interchangeable adapter-hubs to fit both standard NEMA and IEC motor shafts.

Application Flexibility

Viking's CMD series' non-metallic construction delivers a broad range of chemical compatibility. Its sealless design provides trouble-free performance where liquid containment is crucial to environmental requirements. This pump series is ideally suited for low-flow operation where centrifugal pumps perform inefficiently and can experience cavitation, increased radial loads and unstable flow. Designed with simple serviceability in mind, you can replace all of the typical wear components easily by removing only the front cover, maximizing uptime.

Lower Cost of Ownership

Non-metallic construction eliminates the need for expensive alloys. Sealless design eliminates service requirements of mechanical seals and expensive seal flush systems. Advanced design utilizes fewer parts (16 fabricated parts) minimizing maintenance time and inventory requirements. Patent pending casing liner transfers wear from casing to replaceable liner, which is part of the recommended spare parts kit, to provide cost-effective, 100% renewal of CMD pump efficiency and performance for a lower total cost of ownership.

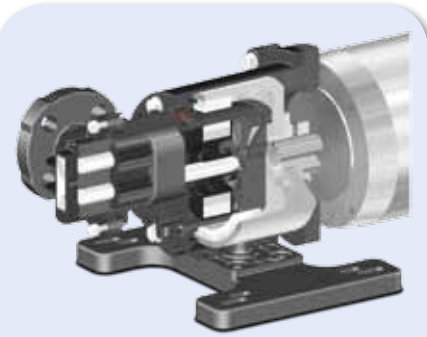

CMD Series' Benefits

Vs. Other Mag Drive Gear Pumps:

- CMD offers broad chemical resistance, enabling one pump to be used on many different liquids.

Vs. Non-metallic Mag Drive Centrifugal Pumps:

- CMD offers high efficiencies, reducing energy usage.
- CMD offers flow proportional to speed for chemical metering.
- CMD handles viscosities from less than 1 to 5,000 cSt, enabling use of one pump on many different liquids.

Vs. Diaphragm Metering Pumps:

- CMD handles entrained gases better, resulting in lower chance of vapor lock on liquids that off-gas, like sodium hypochlorite.
- CMD offers continuous flow instead of pulsating flow, to eliminate "slug" feeding of chemicals and ensure better mixing.

Vs. Air Operated Double Diaphragm (AODD) Pumps:

- CMD electric motor drive ensures lower energy usage than compressed air.
- Eliminates pulsation.

Performance Envelope

60 Hz – 1750 RPM:

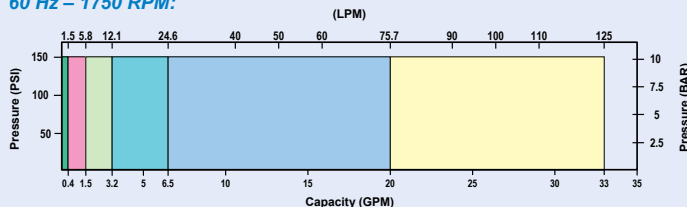

50 Hz – 1450 RPM:

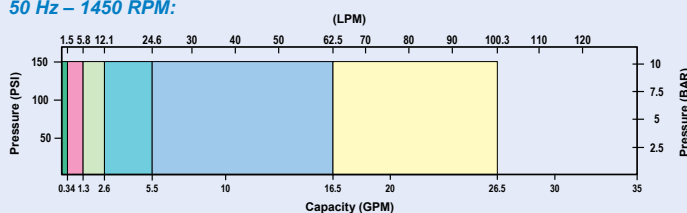

Corrosive Chemicals



These pumps handle a broad pH range, allowing the same pump to be used for a variety of liquids. They are designed for metering liquids in process control systems as well as for simple tank-to-tank transfer. The fluoropolymer and ceramic wetted materials in these pumps are compatible with many corrosives, yet are more affordable than pumps made of Alloy 20, Alloy C, titanium and other exotic materials required to handle some highly corrosive materials.

Typical Applications:

- Acids: Hydrochloric, Nitric, Phosphoric, Sulfuric
- Bases: Sodium Hydroxide
- Coagulants: Ferric Chloride
- Disinfectants: Sodium Hypochlorite

Volatile Organic Chemicals & Flammable Liquids

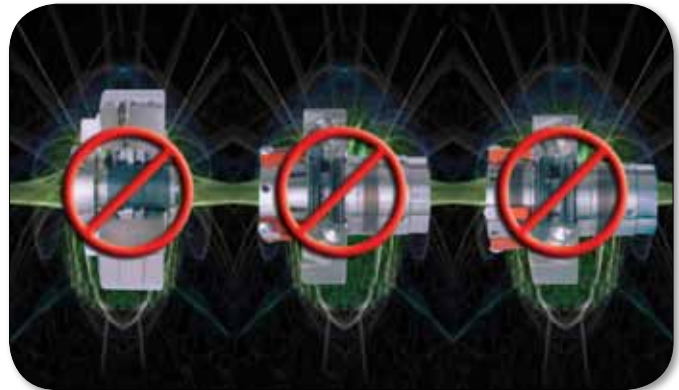

These pumps use a magnetic drive system to eliminate the most common source of pump leakage and vapor emissions, the shaft seal. This helps protect employees and the environment, and it prevents infiltration of air into the pump to protect liquids that react with air or water vapor.

Typical Applications:

- Solvents: Acetone, Toluene
- Refrigerants: Freons, Ammonia
- Refined Fuels: Ethanol, Biodiesel
- Adhesives: Cyanoacrylate, Epoxies
- Odorants: Mercaptans, Fragrances, Aldehydes
- Organics: Formaldehyde, Vinyl Chloride Monomer

Model Number Key

| | | | | | | |
|--|--|--|---|---|---|--|
| <h1>CMD</h1> <p>CMD = Series: Composite Mag Drive</p> | <h1>-E02</h1> <p>Model ① E02 E05 E12 E25 E75 E125</p> | <h1>E</h1> <p>Primary Material: E= ETFE / NPT K= PVDF / NPT (E02, E05, E12) B= ETFE / BSPT, ISO 7-1 M= PVDF / BSPT, ISO 7-1 (E02, E05, E12) F= ETFE / Flange N= PVDF / Flange (E25, E75, E125)</p> | <h1>L</h1> <p>Bearings: L= Carbon Graphite B= Carbon-Impregnated Silicon Carbide</p> | <h1>V</h1> <p>O-Rings: V=Viton® E= EPDM K= Kalrez Grade 4079</p> | <h1>F</h1> <p>Motor Mounting Arrangement ② F = NEMA 56C (E02, E05, E12, E25, E75) O = NEMA 143/5TC - 182/4C (E02, E05, E12, E25, E75, E125) R = NEMA 182TC - 184TC (E75, E125) W = NEMA 213TC - 215TC (E75, E125) H = IEC 63 B3/14 (E02, E05, E12) J = IEC 71 B3/14 (E02, E05, E12) K = IEC 80 B3/14 (E02, E05, E12, E25, E75) L = IEC 90 B3/14 (E25, E75) P = IEC 100/112 B3/14 (E25, E75, E125) Y = No Motor Mount Kit (E02, E05, E12, E25, E75, E125)</p> | <h1>-X</h1> <p>Options: X = Complete Pump, No Options A = Bearing Flush Port N = Without Drive Magnet (wet end only) B = Combination of A and N</p> |
|--|--|--|---|---|---|--|

① Export license required under U.S. Export Administration ECCN 2B350 and 2B999 for sizes E12, E25, E75 and E125.

② Motor mounting flanges are available to order. Motors are ordered separately as a line item. Customer is responsible for motor mounting. Option O 182/184C motor requires modified motor shaft and motor bolt pattern. Does not fit frames 182/184TC.

Option Y is for bare pump with drive magnet but not motor mounting hardware (magnet hub or applicable motor adaptor). This is typically used as a spare pump until a specific motor has been identified.

Viking® CMD Series Gear Pump Benefits

ADVANCED DURABILITY

■ Innovative Magnet System

Patent pending spline design allows the magnet to self-align on shaft with no added fasteners. **Eliminates axial loading on shaft, extending pump life.**

■ Heavy-Duty Bearings

Unique flow geometry generates cooling flow through canister. **Provides built-in protection against system upset, extending pump life, allowing vertical mounting.**

■ Non-Metallic Magnet Canister

Minimizes heat rise and magnet inefficiencies due to eddy current losses found in metallic canisters. **Minimizes heat rise to protect sensitive fluids.**

■ Unique, Universal Flange

Universal flange design uses replaceable PTFE raised face flange inserts for easy installation to either ANSI or DIN flanged systems. **Eliminates flange adapters, simplifying installation into virtually any system.**

■ Close-Coupled Mounting

Eliminates coupling, guard, and the cost and issues associated with pump and motor alignment. **Provides quicker, easier installation.**

■ Rotatable Casing

3 smaller sizes have rotatable, motor mount casing with NEMA or IEC adapters. **Permits horizontal or vertical porting for easier installation.**

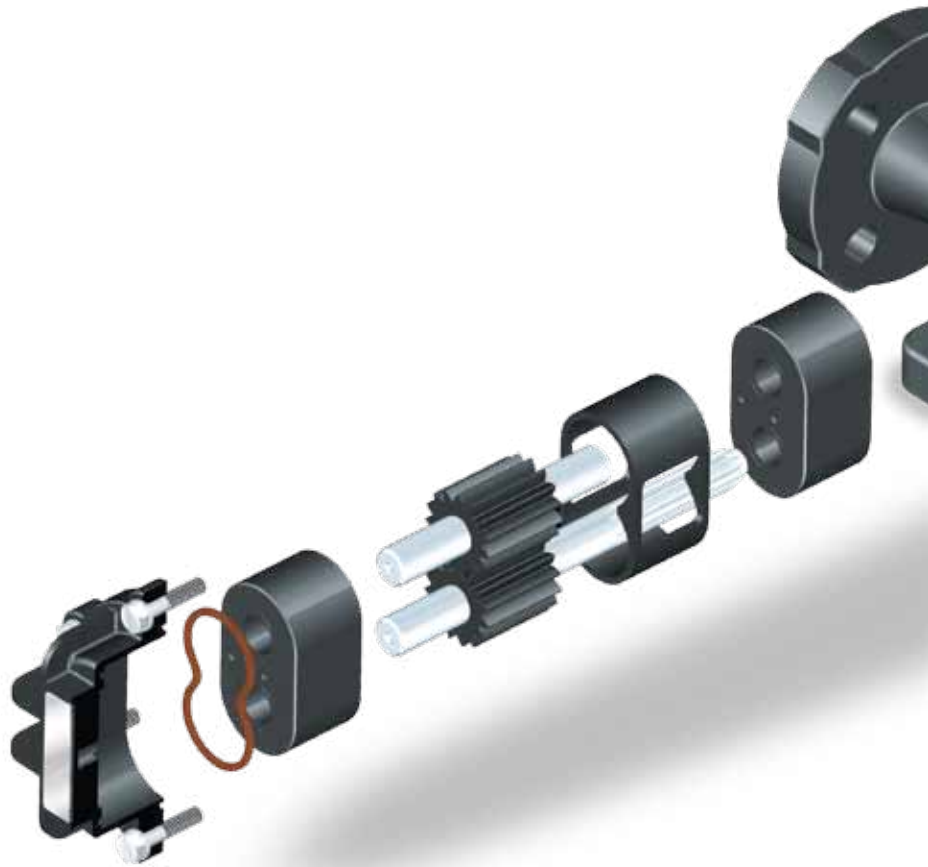

EASY INSTALLATION

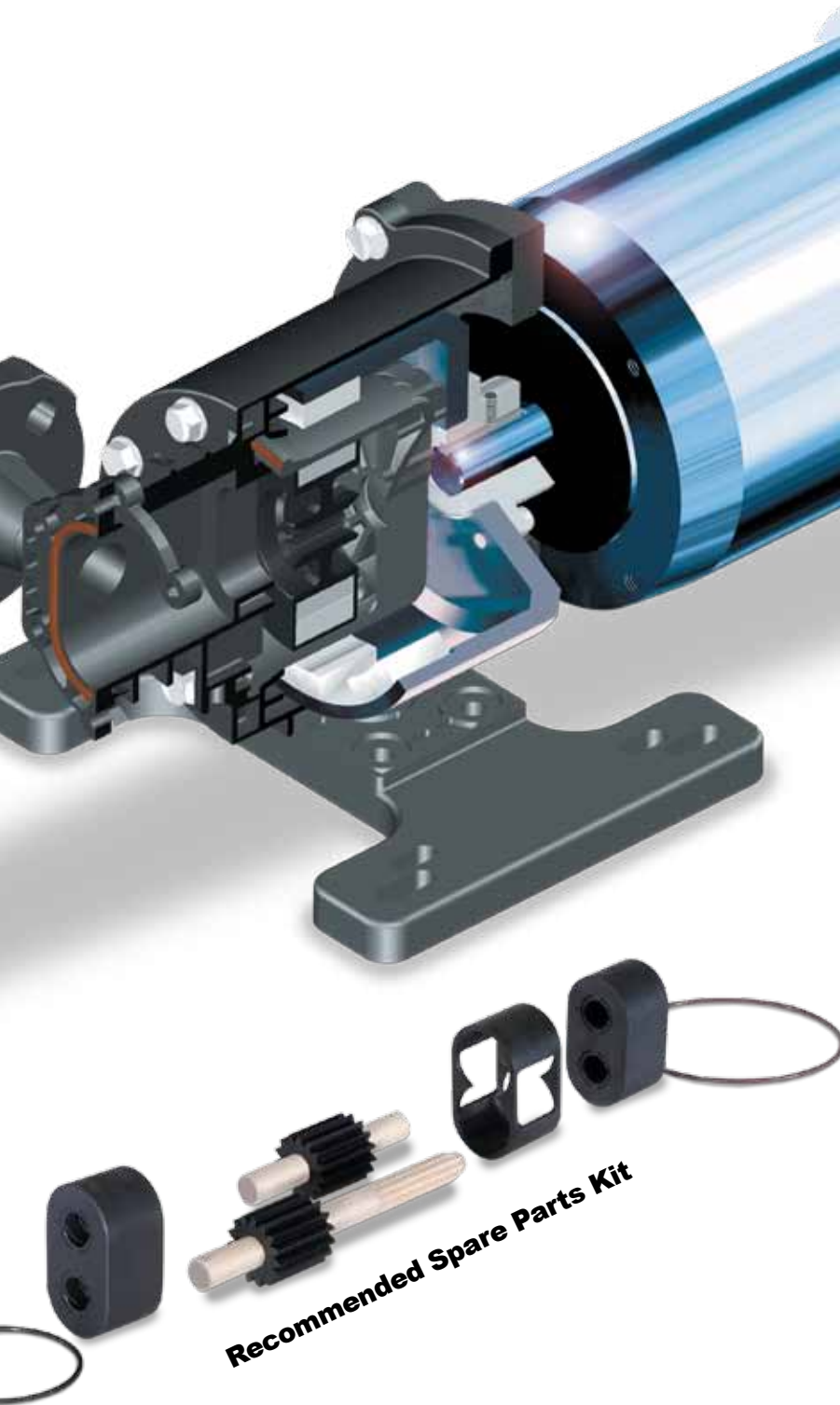

Recommended Spare Parts Kit

APPLICATION FLEXIBILITY

LOWER COST OF OWNERSHIP

■ **Bi-directional Pump Design**

Bi-directional pumping design eliminates cost of second pump, piping, and valving needed for loading/unloading or line stripping. **Provides application flexibility and reduces system costs.**

■ **Modular Magnet Hub and Universal Motor Adapter**

One drive magnet per pump size, with interchangeable adapter-hubs. **Provides easy mating to fit either standard NEMA or IEC motors.**

■ **Broad Chemical Compatibility**

CMD Series' wetted components are made of Engineered Fluoropolymers, Ceramic and Carbon Graphite or Silicon with excellent corrosion resistance and strength over a broad range of chemicals and temperatures. **Enhances application flexibility**

■ **10 Minute Maintenance**

CMD series' normal wear components can be replaced without detachment of pump from system and no special tools required. **Reduces down time and maintenance costs.**

■ **Simple Design**

Advanced non-metallic design utilizes fewer parts (16 fabricated parts) to simplify servicing. **Minimizing maintenance requirements and inventory requirements.**

■ **Renewable Performance**

Regain 100 % performance with the change of a recommended spare parts kit, to keep pump running optimally. **Provides cost-effective renewal of pump performance and efficiency.**

Materials of Construction & Specifications

CMD Gear Pump Construction

| Construction | Casing / Head | Gears | Canister | Inner Magnet Assembly | Outer Magnet Assembly | Shafts | Bearings | O-Rings |
|-----------------|------------------------|------------------------|------------------------|-----------------------------|---------------------------------|-----------------|--|---------------|
| Standard | Carbon Reinforced ETFE | Carbon Reinforced PTFE | Carbon Reinforced ETFE | ETFE Encapsulated Neodymium | Nickel-Plated Steel / Neodymium | Alumina Ceramic | Carbon Graphite | Viton® |
| Optional | Carbon-Filled PVDF | N/A | Carbon-Filled PVDF | N/A | N/A | N/A | Graphite-Impregnated Silicon-Carbide, Encapsulated Viton-A, Kalrez® Grade 4079 | EPDM, Kalrez® |

CMD Gear Pump Specifications

| Pump Model | Ports | | 22 cSt (100 SSU) Performance | | | | Maximum Differential Pressure | | Maximum Hydrostatic Pressure | | Maximum Recommended Temperature | | Approximate Shipping Weight | |
|------------|--------------------|----------|------------------------------|-------|------------------------------|-------|-------------------------------|-------|------------------------------|-----|---------------------------------|--------|-----------------------------|-----|
| | Type | Size in. | Nominal Capacity at 1450 RPM | | Nominal Capacity at 1750 RPM | | | | | | | | | |
| | | | GPM | LPM | GPM | LPM | BAR | PSI | BAR | PSI | Deg. C | Deg. F | kg. | lb. |
| E02 | NPT ISO 7-1 | 1/4 | 0.34 | 1.3 | 0.4 | 1.5 | 10 | 150 | 14 | 200 | 65 | 150 | 2 | 4 |
| E05 | NPT ISO 7-1 | 3/8 | 1.3 | 4.9 | 1.5 | 5.8 | 10 | 150 | 14 | 200 | 65 | 150 | 5 | 9 |
| E12 | NPT ISO 7-1 | 3/4 | 2.6 | 10.0 | 3.2 | 12.1 | 10 | 150 | 14 | 200 | 65 | 150 | 6 | 10 |
| E25 | ANSI Flg. DIN Flg. | 1 | 5.5 | 21.0 | 6.5 | 24.6 | 10 | 150 | 14 | 200 | 65 | 150 | 12 | 26 |
| E75 | ANSI Flg. DIN Flg. | 1-1/2 | 16.5 | 62.5 | 20.0 | 75.0 | 10 | 150 ① | 14 | 200 | 65 | 150 | 20 | 44 |
| E125 | ANSI Flg. DIN Flg. | 1-1/2 | 26.5 | 100.0 | 33.0 | 125.0 | 7 | 100 ② | 14 | 200 | 65 | 150 | 20 | 44 |

① 150 PSI / 10 BAR with Silicon Carbide bearings;
100 PSI / 7 BAR max. pressure with Carbon Graphite bearings.

② 100 PSI / 7 BAR with Silicon Carbide bearings;
80 PSI / 5.5 BAR max. pressure with Carbon Graphite bearings.

Viton® and Kalrez® are registered trademarks of DuPont Performance Elastomers.

Dimensions



Dimensions For E02, E05 & E12

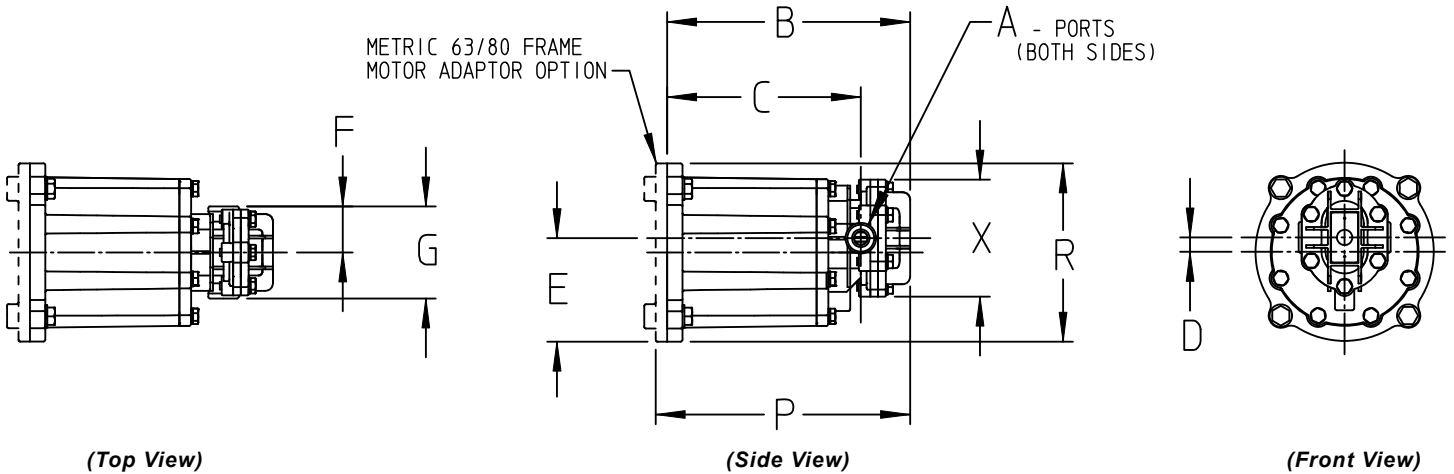

| Model | | A | B | C | D | E | F | G | P | R | X |
|-------|-----|--------------------------|--------|--------|-------|-------|-------|-------|--------|--------|-------|
| E02 | mm | 1/4 Inch FNPT or ISO 7-1 | 183.50 | 154.40 | 6.40 | 80.20 | 34.90 | 69.90 | 193.00 | 147.60 | 76.20 |
| | in. | | 7.22 | 6.08 | 0.25 | 3.16 | 1.38 | 2.75 | 7.60 | 5.81 | 3.00 |
| E05 | mm | 3/8 Inch FNPT or ISO 7-1 | 201.20 | 160.30 | 11.90 | 85.60 | 38.10 | 76.20 | 210.70 | 147.60 | 96.80 |
| | in. | | 7.92 | 6.31 | 0.47 | 3.37 | 1.50 | 3.00 | 8.93 | 5.81 | 3.81 |
| E12 | mm | 3/4 Inch FNPT or ISO 7-1 | 217.00 | 168.30 | 11.90 | 85.60 | 47.60 | 95.30 | 226.60 | 147.60 | 96.80 |
| | in. | | 8.54 | 6.63 | 0.47 | 3.37 | 1.88 | 3.75 | 8.93 | 5.81 | 3.81 |

NOTE: Pumps must be mounted to a footed motor with a face (NEMA C or Metric B34). Will accept motors with or without a foot/rigid base. Pump foot is removable.

Dimensions For E25, E75 & E125

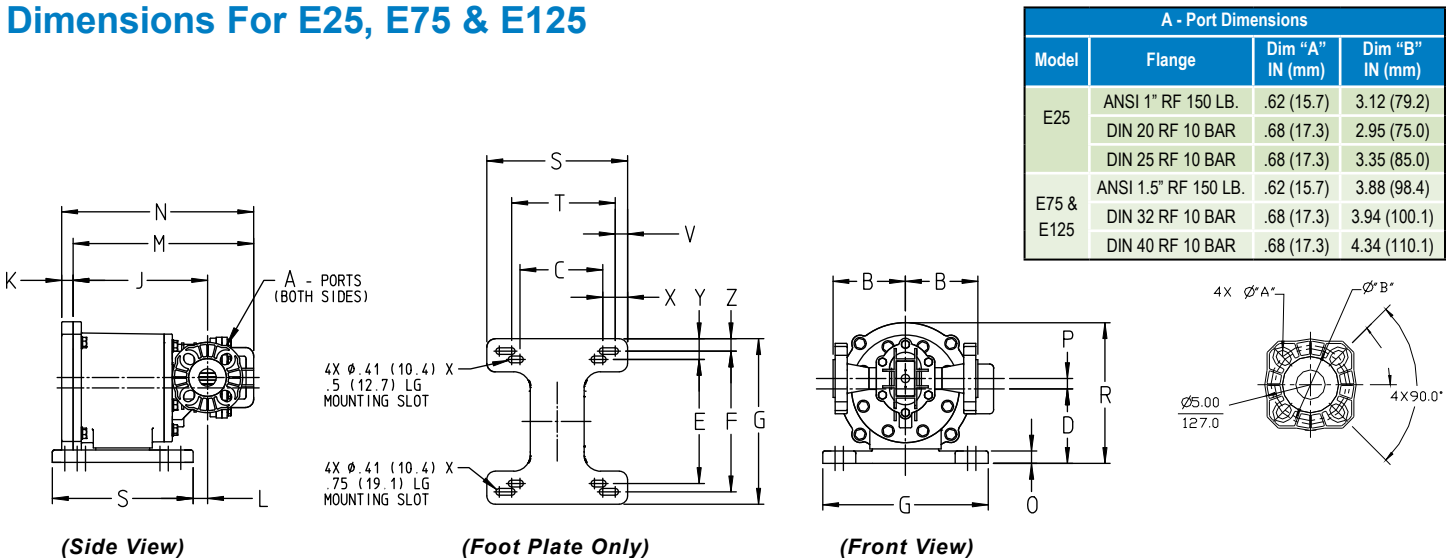

| A - Port Dimensions | | | |
|---------------------|----------------------|-----------------|-----------------|
| Model | Flange | Dim "A" IN (mm) | Dim "B" IN (mm) |
| E25 | ANSI 1" RF 150 LB. | .62 (15.7) | 3.12 (79.2) |
| | DIN 20 RF 10 BAR | .68 (17.3) | 2.95 (75.0) |
| | DIN 25 RF 10 BAR | .68 (17.3) | 3.35 (85.0) |
| E75 & E125 | ANSI 1.5" RF 150 LB. | .62 (15.7) | 3.88 (98.4) |
| | DIN 32 RF 10 BAR | .68 (17.3) | 3.94 (100.1) |
| | DIN 40 RF 10 BAR | .68 (17.3) | 4.34 (110.1) |

| Model | | B | C | D | E | F | G | J | K | L | M | N | O | P | R | S | T | V | X | Y | Z |
|------------|-----|--------|----------|--------|----------|----------|--------|--------|-------|-------|--------|--------|-------|-------|--------|--------|----------|---------|----------|----------|---------|
| E25 | mm | 111.10 | 127.00 | 114.30 | 190.50 | 215.90 | 254.00 | 206.40 | 17.50 | 22.20 | 277.10 | 294.6 | 19.10 | 15.90 | 215.90 | 215.90 | 158.8 | 19.00 | 38.10 | 31.7 | 19.00 |
| | in. | 4.38 | 2 X 5.00 | 4.50 | 2 X 7.50 | 2 X 8.50 | 10.00 | 8.12 | 0.69 | 0.88 | 10.91 | 11.6 | 0.75 | 0.62 | 8.50 | 8.50 | 2 x 6.25 | 2 x .75 | 2 x 1.50 | 2 x 1.25 | 2 x .75 |
| E75 & E125 | mm | 127.10 | 127.00 | 136.50 | 190.50 | 215.90 | 254.00 | 241.30 | 25.40 | 57.10 | 349.60 | 375.00 | 19.10 | 23.80 | 257.20 | 215.90 | 158.80 | 19.00 | 38.10 | 31.7 | 19.00 |
| | in. | 5.00 | 2 X 5.00 | 5.38 | 2 X 7.50 | 2 X 8.50 | 10.00 | 9.50 | 1.00 | 2.25 | 13.77 | 14.77 | 0.75 | 0.93 | 10.12 | 8.50 | 2 x 6.25 | 2 x .75 | 2 x 1.50 | 2 x 1.25 | 2 x .75 |

NOTE: Pumps must be mounted to a motor with a face (NEMA C or Metric B34). Will accept motors with or without a foot/rigid base. Pump foot is removable.



A Unit of IDEX Corporation

Leader in Positive Displacement Pumping Solutions.

Innovation and Experience

Viking Pump has been a pump industry leader and innovator since its founding in 1911. We continue to build on our ever growing experience delivering innovative new pumping solutions, including custom designs, to thousands of customers who use Viking pumps in some of the world's toughest applications.

Broad Performance Range

Capacity:

0.5 to 360 M³/Hr (0.1 to 1,600 GPM)

Pressure:

0 to 172 Bar (0 to 2,500 PSI)

Temperature:

-84°C to 370°C (-120°F to 700°F)

Viscosity:

0.5 to 1,000,000 cSt (28 to 4,500,000 SSU)

Ultimate in Sealing Solutions

Viking's offering of packing, component mechanical seals, cartridge seals and sealless Mag Drive technology provides the best choices for sealing flexibility needed to provide your application a customized sealing solution every time - saving you money, time and unplanned downtime.

Material Options Matched to Application

Viking's dedicated iron and alloys foundries provide pump construction materials from cast iron to Alloy C. Application-specific materials of construction extend a pump's life significantly, while reducing maintenance and unplanned downtime, enabling increased production and a better bottom line.

Liquid Integrity Protection

Viking has developed multiple positive displacement pump principles to protect shear-sensitive liquids, and low-shear options to prevent damage to fibers, polymers and solids. Full-jacketing options provide precise temperature control throughout the pump. The Viking Mag Drive[®] and other seal options prevent fluid contact with air, assuring liquid integrity.

Local Applications and Engineering Support

Over 245 Authorized Viking Pump Distributors in 68 countries provide local application support and service. They are backed by Viking Application Engineers and Viking Region Managers strategically located around the world.

Quality Manufacturing

Viking uses ISO9001-2008, Six-Sigma, and Lean/Kaizen in its worldwide manufacturing and assembly processes to remove waste, reduce development costs, and deliver superior products. Dedicated Viking foundries and manufacturing facilities utilize state-of-the-art CNC equipment to assure unmatched quality is built into every pump.

Custom Designed Solutions

Viking has provided custom designed pumps to end-users and OEMs since its first pump in 1911, when Viking invented the gear-within-a-gear pumping principle to remove water from a rock quarry. Today, enabled by Viking's engineering staff, extensive applications experience and in-house foundries, more than 20% of Viking's sales are new designs or pump designs derived from one of our 40,000 active configurations. Whether you are an end-user or an OEM, Viking can provide custom designed pumping solutions to meet your specific needs.



For more information, contact your local Authorized Viking Pump Distributor or contact Viking at:

VIKING PUMP, INC.

A Unit of IDEX Corporation
406 State Street
Cedar Falls, Iowa 50613 U.S.A.
Phone: (319) 266-1741
Fax: (319) 273-8157
Email: info.viking@idexcorp.com
www.vikingpump.com

CANADA

Windsor, Ontario
Phone: (519) 256-5438
Fax: (519) 256-5070
www.vikingpumpcanada.com

EUROPE

Shannon, Ireland
Phone: +353 (61) 471933
Fax: +353 (61) 475046
www.vikingpumpeurope.co.uk

LATIN AMERICA

Mexico D.F., C.P.
Phone: +52 (55) 5255-1357
Fax: +52 (55) 5255-1356
Brazil - Sao Paulo
Phone: +55 (19) 3871-3500
Fax: +55 (19) 3871-6400

ASIA-PACIFIC GROUP

Singapore
Phone: +65-6763-6633
Fax: +65-6764-4020
www.idexfmt-asia.com

China - Shanghai
Phone: +86-21-5241-5599
Fax: +86-21-5241-8339
www.idexfmt-asia.com

China - Beijing
Phone: +86-10-6566-9090
Fax: +86-10-6567-5152
www.idexfmt-asia.com

China - Guangzhou
Phone: +86-20-3886-6156
Fax: +86-20-3886-2776
www.idexfmt-asia.com

India - Mumbai
Phone: +91-22-66780049/53
Fax: +91-9820334270
www.idexfmt-asia.com

ASIA-PACIFIC GROUP

China - Chengdu
Phone: +86-28-86767458
Fax: +86-28-86767468
www.idexfmt-asia.com

China - Suzhou
Phone: +86-512-62833000
Fax: +86-512-62833010
www.idexfmt-asia.com

Korea - Seoul
Phone: +82-19-9134-1110
Fax: +82-2-556-0788
www.idexfmt-asia.com

Australia & New Zealand
Phone: +61 0 4577 4534
Fax: +61 0 448 480 640
www.idexfmt-asia.com

MIDDLE EAST

IDEX Middle East FZE
Dubai, UAE
Phone: +971-4-299-1095/1097
Fax: +971-4-299-1069
www.idexfmt-asia.com