

INSTALLATION, OPERATION, PARTS & MAINTENANCE MANUAL



M-15 & M-25 ***Aluminum-Body Meters***

**LIQUID
CONTROLS**
A Unit of IDEX Corporation

IDEX
IDEX CORPORATION



Exploded View: M-15/M-25 Meter Covers

The 0250 Packing Gland is field servicable. See "Servicing the Drive Components" in the M/MA Meter Manual.

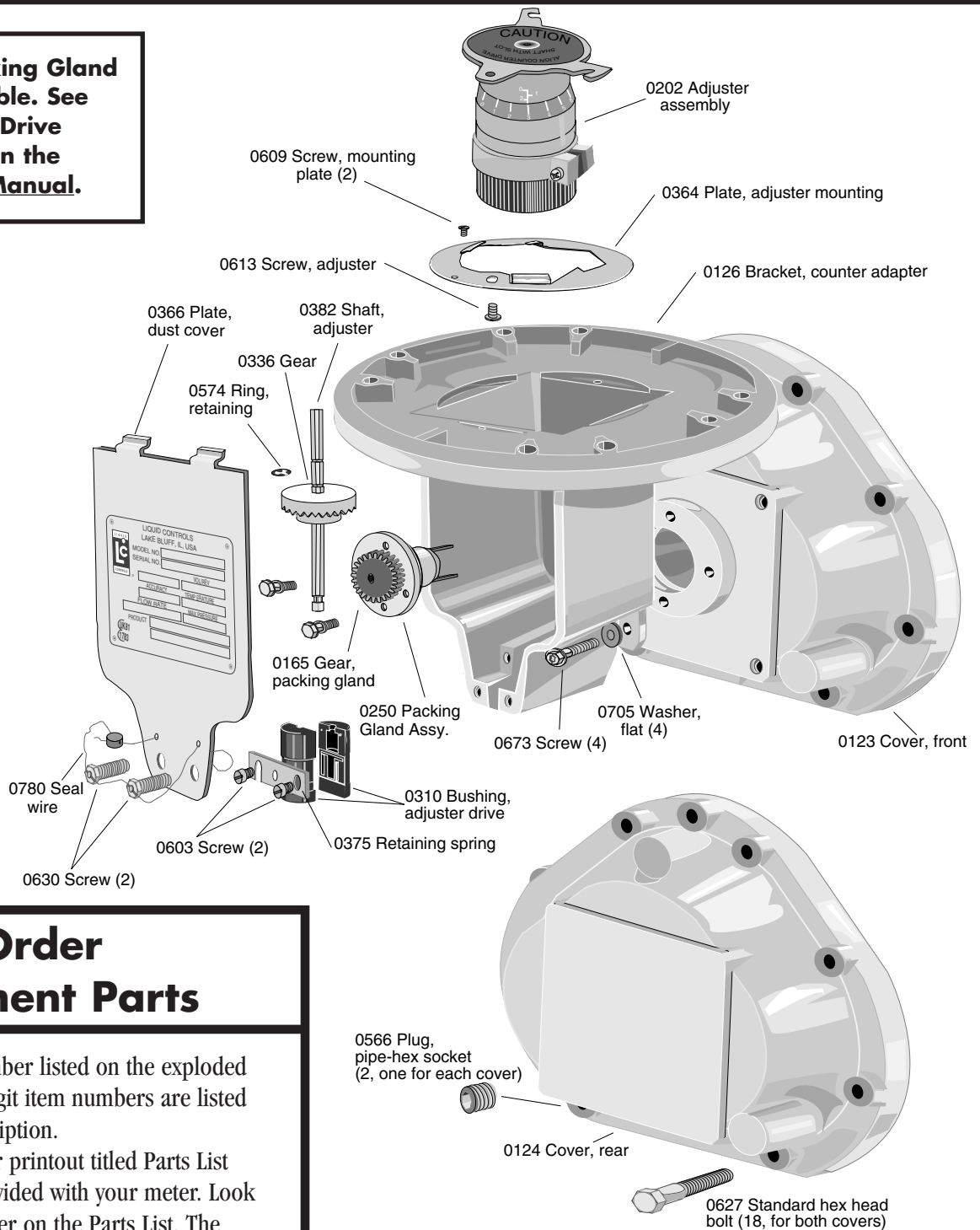

How to Order Replacement Parts

1. Find the item number listed on the exploded drawing. The 4 digit item numbers are listed with a word description.
2. Find the computer printout titled Parts List that has been provided with your meter. Look up the item number on the Parts List. The Parts List shows each item number with a corresponding part number. Find the corresponding 5 digit part number for the item you want to order. The part number represents an individual piece, a kit or a complete assembly.
3. Inform your distributor of the part number that you need. The part number is the only number that allows the distributor to find the correct component for your meter.

Exploded View: M-15/M-25 Meter Element

When placing order for replacement parts please reference the meter's serial number.

Front cover ← → Rear cover

LIQUID CONTROLS LAKE BLUFF, IL, USA	
MODEL NO.	VOL/REV
SERIAL NO.	TEMPERATURE
MMQ	ACCURACY
FLOW RATE	MAX PRESSURE
PRODUCT	
UK81 1782	

0570 Pipe plug (optional)

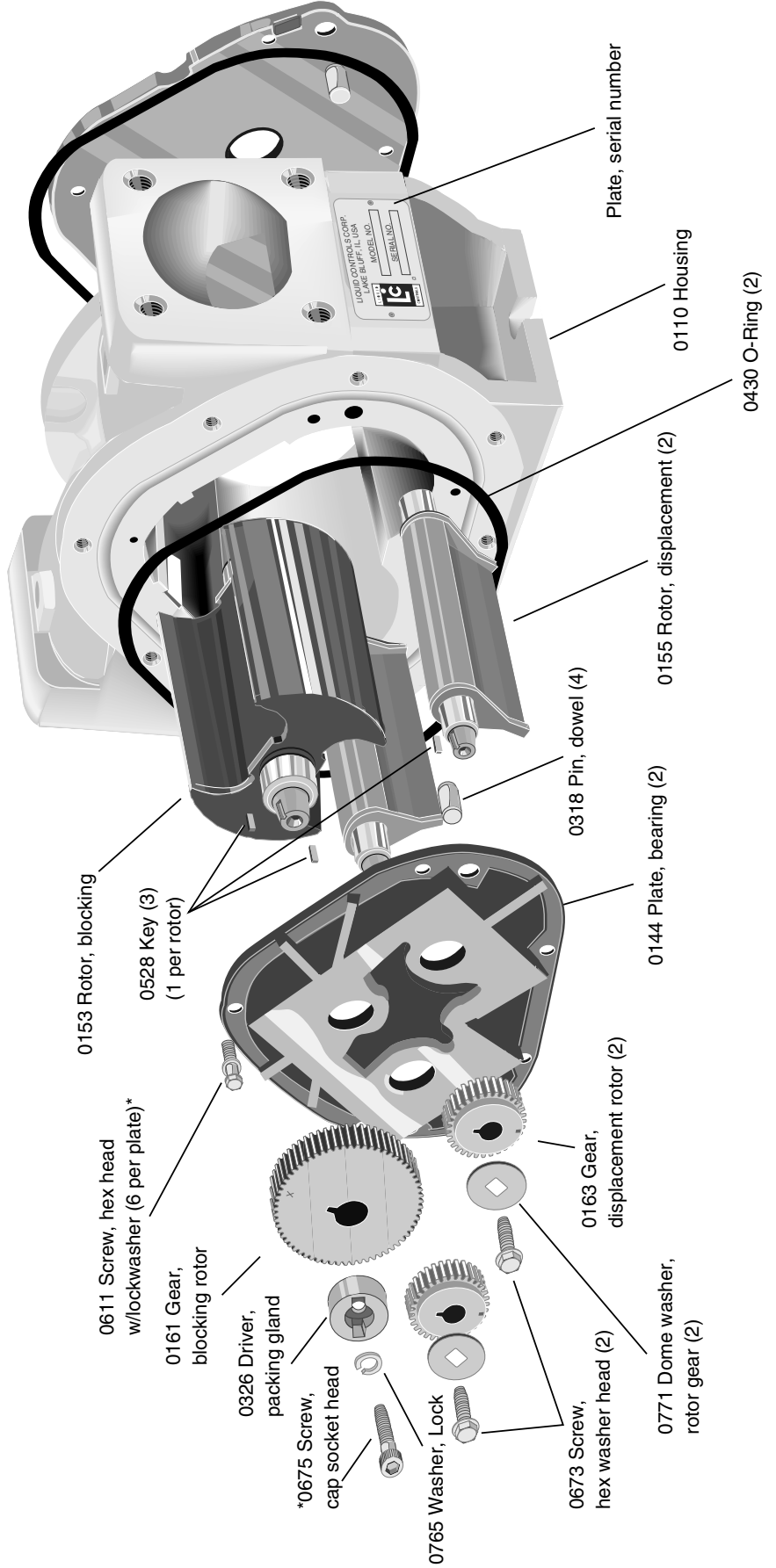

SOLD AND SERVICED BY A NETWORK OF HIGHLY TRAINED FULL SERVICE DISTRIBUTORS

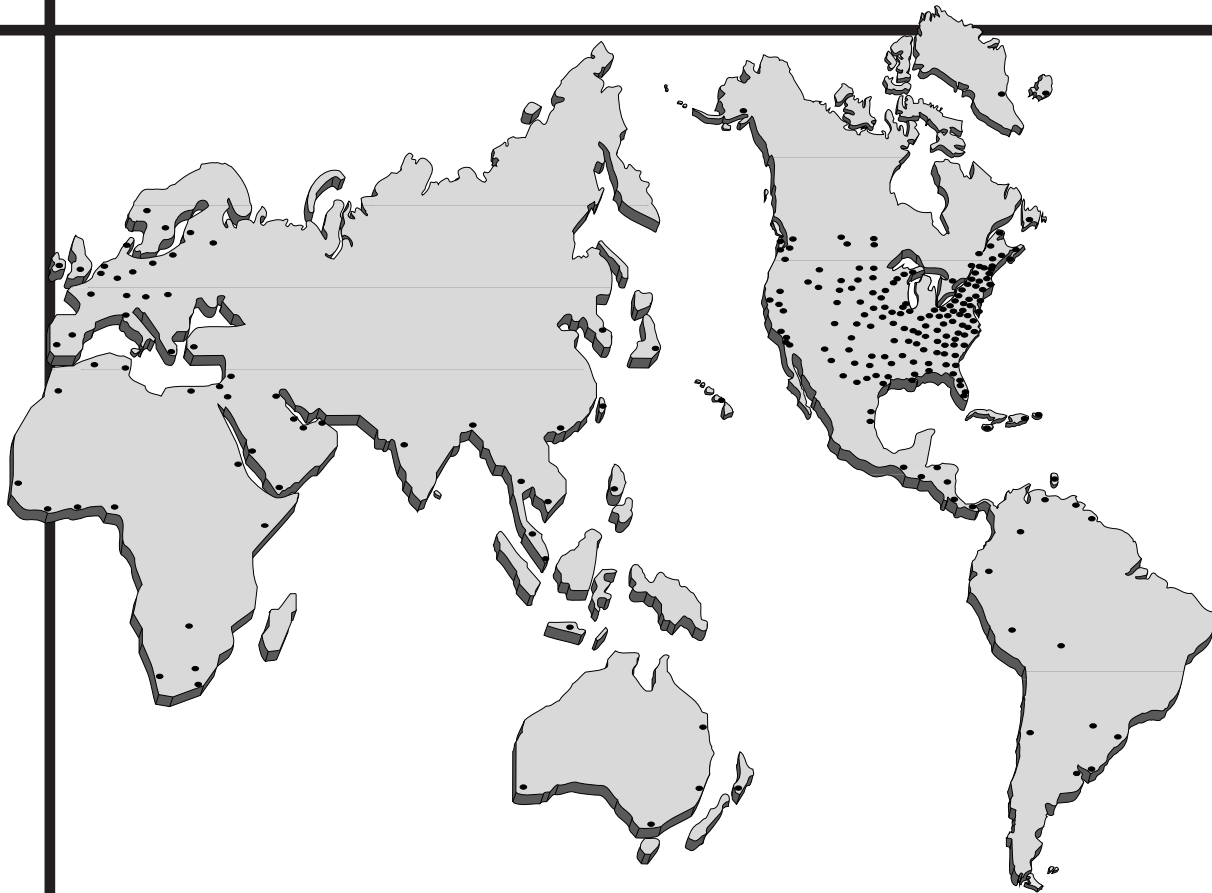

Backed By Our Worldwide Reputation For Quality, Accuracy and Advanced Design.

WARRANTY:

Liquid Controls ("Seller") products are warranted against defects in material or workmanship for a period of one (1) year from date of installation, provided that the warranty shall not extend beyond twenty-four (24) months from the date of original shipment from Seller. Seller's obligations, set forth below, shall apply only to failure(s) to meet the foregoing obligations provided that Seller is given written notice within thirty (30) days of any occurrence from which a claim of defect arises. If a warranty dispute occurs, the Purchaser shall be required to provide Seller with proof of date of sale. The minimum requirement to establish date of sale shall be a copy of the Seller's invoice. In the event that a factory inspection by Seller or its designee(s) supports the validity of a claim, at the discretion of Seller, repair, replacement or refund shall be the sole remedy for defect and shall be made, free of charge,

ex-works factory. In no event shall Seller be liable for any special, consequential, incidental, indirect or exemplary damages arising out of warranty, contract, tort (including negligence) or otherwise, including but not limited to, loss of profit or revenue, loss of use of the product or any associated products and/or equipment, cost of substitute goods or services, downtime costs or claims of or by Purchaser's clients or customers. In any event, the total liability of Seller for any and all claims arising out of or resulting from the performance, non-performance or use of the product shall not exceed the purchase price of the individual product giving rise to the claim. All other guaranties, warranties, conditions and representations, either express or implied, whether arising under any statute, common law, commercial usage or otherwise are excluded. Electronic Products require installation, start-up and servicing by local factory-trained service representatives. In the

absence of installation, start-up and servicing of Electronic Products by Seller trained service representatives, this warranty is null and void. Seller's obligations as set forth above shall not apply to any product, or, or any component or part thereof, which is not properly installed, used, maintained or repaired, or which is modified other than pursuant to Seller's instructions or approval. NOTE: The above warranty applies only to products manufactured by Liquid Controls, Lake Bluff, Illinois. Private label, OEM, and/or products manufactured by Liquid Controls licensee(s) are specifically excluded from the above warranty. Consult factory for all non-Liquid Controls manufacturers' warranties. NO IMPLIED OR STATUTORY WARRANTIES OF MERCHANTABILITY OR FITNESS FOR A PARTICULAR PURPOSE SHALL APPLY.

Backed By Our Worldwide Reputation For Quality, Accuracy and Advanced Design.

**LIQUID
CONTROLS**
A Unit of IDEX Corporation



LIQUID CONTROLS
A Unit of IDEX Corporation
105 Albrecht Drive
Lake Bluff, IL 60044-2242
(847) 295-1050
FAX: (847) 295-1057
Website: www.lcmeter.com

Distributed By:



CERTIFICATED FIRM
Certificate No. 8732

Printed with vegetable inks on recycled paper. Please Recycle!