

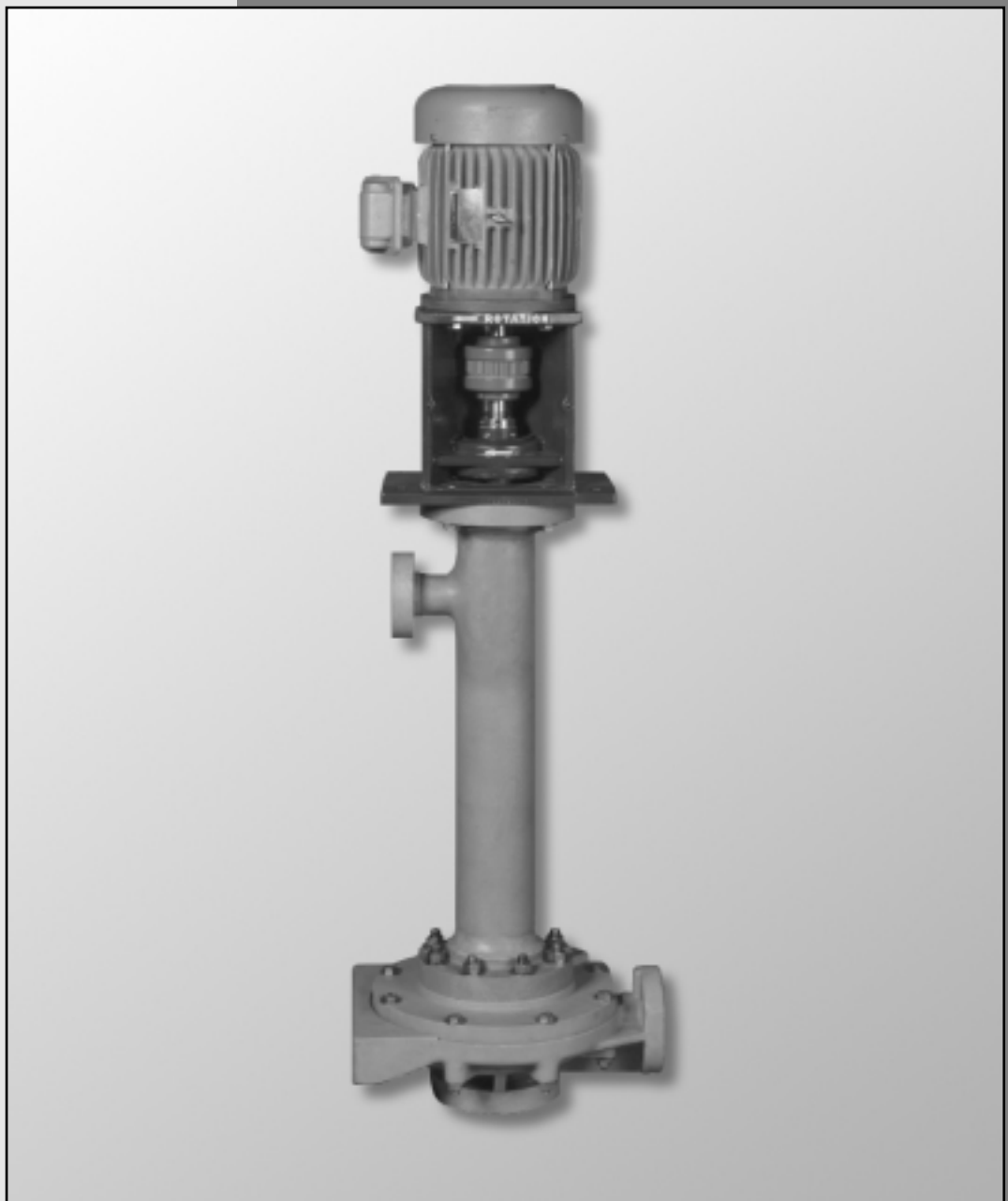

Fybroc Division

series 5530 vertical dry pit pump

INSTALLATION MANUAL



INDEX

	Page		Page
Fybroc Warranty	2	Starting	7
Installation Instructions	3	Operational Check List	7
General Description	4	Maintenance	7
Location	4	Trouble Check List	8
Pump Installation	4	Assembly/Disassembly Procedures	9
Piping the Pump	4	General	9
Suction Piping	5	Disassembly	9
Discharge Piping	5	Assembly	10
Column Return Piping	5	Impeller Adjustment	11
Ancillary Piping	5	Sectional Drawing	12
Motor Installation	5	Outline Drawing	13
Electrical Connections	5	Operational Start-up Checklist	14
Rotation	5	Notes	15
Coupling Installation	6	Notes	16
Start-up and General Operating Procedures	7	Notes	17
Lubrication	7		

ORDERING REPLACEMENT PARTS

For future reference fill in the following information from the pump nameplate. This will be necessary to ensure accuracy when ordering replacement parts.

Model _____

Size _____

Serial Number _____

Impeller Diameter Installed _____

Material of Construction _____



Fybroc Division

WARRANTY

FYBROC pumps are warranted by the Company, insofar as the same are of its own manufacture, against defects in materials and workmanship under proper and normal use and service, for a period of one year from the date of original shipment from the factory. FYBROC's obligation is limited, however, to furnishing without charge, F.O.B. its factory, new parts to replace any similar parts of its own manufacture so proving defective within said period, provided the Buyer has given FYBROC immediate written notice upon discovery of such defect. No allowance will be made for labor charges. FYBROC shall have the option of requiring the return of the defective material, transportation prepaid, to establish the claim.

FYBROC makes no warranty or guarantee whatsoever, either express or implied, of prime mover, starting equipment, electrical apparatus, parts or material not manufactured by Fybroc, except to the extent that warranty is made by the manufacturer of such equipment and material.

FYBROC assumes no liability for damages or delays caused by defective material, and no allowance will be made for local repair bills or expenses without the prior written approval or authority of FYBROC.

Under no circumstances will FYBROC be liable for indirect, special or consequential loss or damage of any kind and the Buyer assumes all liability for the consequences of its use or misuse by the by the Buyer, his employees, or others.

PERFORMANCE GUARANTEE

Is at the specified point of rating only and will not cover performance under conditions varying therefrom, nor for sustained performance over any period of time.

ACCEPTANCE TESTS

If required, shall be conducted in accordance with the practices as set forth in the Hydraulic Institute Standards. The expense of any such tests shall be borne by the buyer.

PERFORMANCE PRESENTATIONS

Are based on shop laboratory tests with cold water as outlined in the Hydraulic Institute Standards.

FIELD TESTING

Due to the inaccuracies of field testing, the results of any such tests conducted by or for the Buyer shall be interpreted as being only indicative of the actual field performance of the pump. No equipment will be furnished on the basis of acceptance by results of field tests. If the buyer, after such a test, questions the performance of the pump, he may at his option request a test to establish the performance. Such tests will be conducted in accordance with the above paragraph entitled "Acceptance Tests."

ALL WARRANTIES

Are void if -

- a. Pipe strains are the cause of damage.
- b. Pump handles liquids other than those specified in detail.
- c. NPSH lower than required by pump impeller.
- d. Operating speed is higher than specified.
- e. Improper field installation.

To combat corrosion, abrasion, erosion, or pumping solids, foreign objects, or pumping liquids at elevated temperature, any such recommendations will be based on the best available experience of FYBROC and the supplier of the material and industry, BUT WILL NOT CONSTITUTE A GUARANTEE AGAINST THESE EFFECTS.

RECOMMENDATIONS FOR SPECIAL MATERIALS

The foregoing warranty is made in lieu of all other warranties guarantees, obligations or liabilities, expressed or implied, by FYBROC or its representatives. All statutory or implied warranties, other than of title, are hereby expressly negated and excluded.

All illustrations and provisions in specifications are descriptive and are not intended as warranties. Penalty of any kind are not acceptable unless approved in writing by an officer of Met-Pro Corporation.

INSTALLATION 5530 SERIES PUMPS

GENERAL DESCRIPTION

Fybroc dry pit vertical pumps, (Series 5530) are centrifugal type pumping units designed for installation in dry sumps or on the side of liquid tanks vented to atmospheric pressure. Series 5530 vertical pumps contain one non-metallic sleeve bearing which is lubricated and cooled internally by the pumped fluid. The fluid used to cool the bearing is returned to the liquid source through a 1-1/2" column return flange. All pump parts in contact with fluid are constructed of glass reinforced vinyl ester (VR-1) or epoxy (EY-2) resin with the exception of the shaft bearing sleeve, which is of an alloy compatible with the pumped fluid.

LOCATION

The pump should ideally be placed as close as possible to the liquid supply source. It should also be positioned relative to the liquid level such that the pump will not run dry and that the liquid level will not rise above the return line from the column. Sufficient space should be allowed on the sides and overhead to permit inspection and maintenance work to be performed.

PUMP INSTALLATION

- 1) Inspect pump and any accessories packed with the unit to assure no damage has occurred during transit.

MOTORS ARE SHIPPED SEPARATELY AND SHOULD ALSO BE INSPECTED.

Install the pump assembly in position before mounting the motor to prevent damage.

- 2) **WHEN HANDLING THE PUMP UNIT, IT IS VERY IMPORTANT TO PICK UP THE UNIT BY THE TOP OR MOTOR END.**

A rope or sling should be attached to the bearing pedestal (Item 81) for lifting. Serious damage may result if the unit is picked up by the column (Item 91). The pump assembly must be placed carefully into position. Care must be taken to guide the pump as it is lowered into place to avoid striking the sides.

- 3) When the pedestal is resting in the proper position, check the level of the pedestal, and shim if necessary to level the unit. The pump shaft must be vertical to avoid a bending stress on the shaft column, and to avoid bearing damage during operation. Check the shaft column (Item 91) with a level to be sure the unit is straight and plumb.
- 4) Bolt down the pedestal, and be sure it is adequately supported on both sides.
- 5) Rotate the shaft by hand to be sure no damage has occurred during shipment or installation.

PIPING THE PUMP

Piping must not be connected to the pump until the pump is properly installed and secured. Failure to do so may result in the inability to attain proper alignment later.

The pump has been designed with all necessary strength factors for long, reliable service life. However, due to the composite construction, care must be taken during installation to avoid unnecessary pipe strain. If piping strains are to be encountered, flexible connections are recommended. Flat face flange and full face gaskets are recommended for pump piping, however if raised face flanges or gaskets are to be used, caution must be exercised when tightening the flange bolts so as not to distort or damage the pump flanges. When lined piping is used, flange alignment should be carefully checked. Spacer ring gaskets are recommended to assure parallel alignment of pipe and pump flanges. The following flange bolt torque values should be used:

Flange Size	Bolt Torque
1 1/2"	9-12 ft-lbs.
2"	18-24 ft-lbs.
3"	23-30 ft-lbs.
4"	27-36 ft-lbs.
6"	35-50 ft-lbs.

All piping must be supported independently of the pump. The piping should always line up naturally with the pump flanges. Never draw the piping to the suction or discharge flanges of the pump. Piping loads transferred to the pump column will result in premature bearing wear. Outside installations should be properly compensated for changes in ambient temperatures. Refer to pipe manufacturers standards for proper installation. Omission of this could result in severe strain transmitted to the pump flanges. If expansion joints are to be used, they should be installed in a location to prevent loading of the pump flanges.

The piping should be as short and direct as possible. Avoid all unnecessary elbows, bends and fittings, as they increase friction losses in the piping.

SUCTION PIPING

- 1) To minimize friction loss the length of the suction pipe (from process to pump inlet) should be as short as possible. It is important that NPSH available to the pump be greater than the NPSH required by the pump, long suction runs greatly affect NPSH and should be considered carefully.
- 2) The diameter of the suction pipe should be as large or larger than the pump suction.
- 3) Elbows, fittings, valves or expansion joints should be avoided directly at the suction flange. A straight run of at least 10 pipe diameters into the suction of the pump is recommended.
- 4) If a valve is to be installed in the suction piping, only full flow valves offering a minimum flow disturbance should be used (ball, plug types). These valves should be for shut-off only when the pump is not running, not for throttling or controlling flow. Centrifugal pumps should never be throttled on the suction side.
- 5) Provisions for a suction pressure gauge should be included.

DISCHARGE PIPING

- 1) Installation of a valve in the discharge line that can be used as a flow shutoff for inspection and maintenance is recommended. It should be of a design to allow throttling or flow control.
- 2) The diameter of the discharge pipe should be as large or larger than the pump discharge.
- 3) Provision for a discharge pressure gauge should be included.

COLUMN RETURN PIPING

- 1) Bearing flow column return piping must be arranged for gravity flow back to liquid tank. Liquid level in the tank should never exceed the elevation of the column return flange.

ANCILLARY PIPING

- 1) Where the ancillary piping is connected to the pump only plastic fittings shall be used.

WARNING: FAILURE TO USE PLASTIC FITTINGS MAY RESULT IN DAMAGE TO THE PUMP. TAPERED METAL PIPE THREADS CAN CAUSE CRACKS AND DELAMINATION.

After the piping is complete, again rotate the shaft by hand to be sure no piping loads were transferred to the sleeve bearing resulting in binding which will lead to excessive bearing loads.

MOTOR INSTALLATION

- 1) Install the appropriate coupling half and drive key onto the pump shaft in the extreme downward position.
- 2) Engage the coupling sleeve in the pump coupling half.
- 3) Install the motor coupling half and drive key onto the motor shaft in the extreme upward (close to motor frame) position.
- 4) Attach the motor adapter (if required) to the motor and securely tighten the mounting bolts. Be sure the pilot fit is properly engaged and seated.
- 5) Install the motor assembly onto the pump pedestal and initially engage all of the mounting bolts. After all of the bolts are started, securely tighten the mounting bolts. Be sure the pilot fit is properly engaged and seated.
- 6) **WARNING: CHECK THAT COUPLING SLEEVE IS ENGAGED IN PUMP COUPLING HALF AND DISENGAGED IN MOTOR COUPLING HALF. COUPLING SLEEVE MUST BE DISENGAGED UNTIL CORRECT MOTOR ROTATION IS ESTABLISHED. FAILURE TO DO SO CAN RESULT IN DAMAGE TO PUMP FROM REVERSE ROTATION.**

ELECTRICAL CONNECTIONS

- 1) All electrical work done to the unit should be performed by a qualified electrician. All local, state and federal electrical codes should be adhered to.
- 2) Wire motor according to motor manufacturers instructions. Ensure that all connections and covers are tight and that proper sized wire and switch-gear are used.

ROTATION

All pumps operate in a clockwise direction when viewed from the coupling end of the pump shaft, (see direction arrow on the pump pedestal). Connect electric motor to power supply and jog motor to check rotation. If motor is operating in wrong direction, reverse leads and recheck.

COUPLING INSTALLATION

- 1) After correct motor rotation has been established, lock out motor starter, loosen motor and pump coupling halves and engage coupling sleeve. Position coupling halves to ensure maximum engagement of both shafts and shaft keys and secure coupling halves.
- 2) Coupling alignment is not necessary due to the pilot fits, however check for equal spacing between the coupling halves. This will insure that the motor and motor adapter fits are properly seated.
- 3) Reinstall the coupling guard.

START-UP AND OPERATING PROCEDURES

LUBRICATION

The standard pump assembly is supplied with greased for life ball bearings in the pedestal and provided with an internal flush passage for the lower sleeve bearing. With this method of lubrication there is no further action required.

If the pump is provided with a re-greasable ball bearing, the bearing was pre-lubricated at the factory, and additional lubricant is not required.

If the pump is provided with an external flush for the sleeve bearing, an external water line must be provided for cooling and lubrication of the sleeve bearing.

STARTING

- 1) If pump has been sitting idle for an extended period of time between installation and start-up, it would be advise able to remove the coupling guard and turn the pump shaft by hand to be sure rotating elements are still free.
- 2) Fully open the suction valve. The suction pipe, pump casing and impeller must always be full of liquid before the pump is started.
- 3) Open the discharge valve to approximately 25-50% flow.
- 4) If the pump is equipped with external sleeve bearing flush, open the flush valve to the bearing and adjust to 1/4 -1/3 GPM.
- 5) Start and bring the pump up to operating speed and adjust the discharge valve to the desired flow rate.

WARNING: DO NOT RUN PUMP WITH A CLOSED DISCHARGE VALVE AS THE LIQUID IN THE PUMP WILL RAPIDLY INCREASE IN TEMPERATURE, CAUSING DAMAGE TO PUMP OR BEARING.

WARNING: DO NOT RUN PUMP WITHOUT LIQUID AS THE LOWER SLEEVE BEARING AND SHAFT WILL BE DAMAGED.

OPERATIONAL CHECK LIST

- 1) Periodically check for excessive vibrations and bearing temperatures. Correct if necessary.
- 2) Periodically check pressure gauges and flow-meters for correct flow-rate. Adjust discharge valve if necessary. Correct if necessary.

MAINTENANCE

Fybroc pumps are designed for a long service life. The only scheduled maintenance items are the lubrication intervals for the motor bearings. The standard pump is provided with greased for life ball bearings and requires no maintenance. If the pedestal is provided with a re-greasable ball bearing, follow the same schedule and procedure as for the motor below.

MOTOR

The motor relubrication intervals are greatly influenced by the environment it is in and the length of time it runs. Refer to the following chart for typical relubrication values for motors. Standard duty is when the motor is operated eight hours a day and the environment is free from dust. Severe duty is when the motor runs twenty-four hours per day with exposure to dirt and dust.

Sync RPM Range	Motor Frame Range	Type of Service	
		Standard Duty	Severe Duty
3600	143TC - 256TC	5 Yrs	3 Yrs
	284TC - 286TC	1 Yr	4 Mos
	324TC - 365TC	9 Mos	3 Mos
1800	143TC - 256TC	7 Yrs	3 Yrs
	284TC - 326TC	4 Yrs	1.5 Yrs
	364TC - 365TC	2.5 Yrs	10 Mos
	404TC - 447TC	2 Yrs	8 Mos
1200	143TC - 256TC	7 Yrs	3 Yrs
	284TC - 326TC	4 Yrs	1.5 Yrs
	364TC - 447TC	3 Yrs	1 Yr

Instructions For Lubricating Motors

Before greasing, be sure fittings are clean and free from dirt. Remove grease relief plug or plate, using a poker ensure that the relief tube is clear, then using a low pressure grease gun pump in the required grease. Do not over-grease. After re-lubricating allow motor to run for an hour before replacing relief hardware.

TROUBLE CHECK LIST

Refer to the following diagnostic section if hydraulic problems are encountered in the pump operation.

PROBLEM: Insufficient liquid delivered or not enough pressure.

CHECK: Suction pipe and /or pump casing not filled with liquid.

Speed too low.

NPSHA (Lower than NPSHR, pump will cavitate).

Impeller or suction pipe plugged with solids.

Air pockets in suction line or air leaking in through suction gaskets if dynamic suction pressure is negative.

Suction strainer plugged, if used in suction line.

Insufficient submergence above suction entrance (vortexing).

Air or gases in the liquid.

Impeller diameter (smaller than required).

Mechanical defects (impeller clearance too great, impeller damaged, excessive sleeve bearing clearance).

Pressure gauge or flow meter in poor location.

Viscosity of liquid.

Turbulence at pump suction (bends or area changes near pump entrance).

PROBLEM: Pump takes too much power.

CHECK: Speed too high.

Impeller diameter (larger than required).

Head lower than rating; pumping beyond design point.

Liquid heavier than specified; check viscosity and specific gravity.

Mechanical defects (bent shaft, rotating element binds, misalignment, piping loads).

Motor defects.

Foreign object trapped in impeller.

ASSEMBLY PROCEDURES FOR HORIZONTAL PUMPS

GENERAL

The Fibroc pump is designed for easy inspection and service. For inspection or replacement of certain parts, the work can be done in place, without the necessity to remove the complete pump to a maintenance area. Refer to applicable Sectional Drawing in this manual for item numbers mentioned below.

Before any work is done the following procedures and precautions should be taken:

- 1) The electric motor should be either disconnected from its power source, or the switch or circuit breaker must be secured in an "off" position so that the motor cannot be accidentally started.
- 2) Depending upon the fluid being pumped, the proper protective equipment should be worn (gloves, mask, respirator, goggles or safety glasses, etc.) to prevent contact with the fluid in the pump or pipelines.
- 3) Check the valves on the suction and discharge lines to be sure they are closed and secured.
- 4) If the pump or piping is provided with a drain, the liquid trapped in the pump and piping should be drained. Care should be taken to either trap the fluid in a container or to divert it to a proper disposal area so that the area around the pump and floor will not be contaminated.

DISASSEMBLY - VERTICAL 5530 SERIES

- 1) Ensure that the motor is shut off and lock out power supply. Check that suction and discharge valves are shut and any liquid is drained.
- 2) Remove coupling guard screws and coupling guard. Loosen coupling set screws and slide coupling halves away from each other. Retighten set screws.
- 3) Ensure motor power is locked out. Disconnect wiring to motor (tag wires for rotation check upon reassembly). Remove motor or motor adapter mounting bolts and lift the motor and its coupling half from the pump.
- 4) Drain liquid from pump as necessary. Remove suction, discharge and bearing flush return line flange bolts and gaskets.

- 5) Attach a hoist or other suitable means for lifting the pump via the cast iron pedestal and remove the four pedestal mounting bolts.
- 6) Carefully lift out the pump and place it in horizontal position with the coupling guard side facing up.
- 7) Remove casing bolts, washers and nuts (Items 1C, 1D & 1E). Lift the column slightly to remove the casing (Item 1). Remove O-ring (Item 73).
- 8) Fix the pump shaft at the coupling and remove the impeller (Item 2) by turning the impeller in a counter clockwise direction when facing the impeller. A strap wrench or similar device may be required to disengage the impeller screw threads. Remove the impeller O-ring (Item 2B).
- 9) Loosen the pump end coupling set screw and remove from the pump shaft along with the key (Item 6A). Loosen the set screw on the threaded collar (Item 66) and unscrew off the shaft. Remove the slinger (Item 40). Loosen the bearing holder set screw (Item 12A).
- 10) Remove the shaft (Item 6) by sliding it out from the cover end. It may be necessary to tap the coupling end of the shaft with a brass bar if the bearing holder set screw has created a burr.

WARNING: DO NOT ATTEMPT TO REMOVE THE SHAFT OUT THE TOP (MOTOR END) OF THE PUMP, AS IT WILL CAUSE DAMAGE TO THE COMPOSITE SHAFT.

- 11) Mark the location of the cover relative to the column flange. Remove the column-cover nuts (Item 11B) and slide the cover off of the column. Remove O-ring (Item 91A).
- 12) Compress and remove the sleeve bearing snap ring (Item 93C). Slide sleeve bearing (Item 93B) and pin (Item 93D) from the cover.
- 13) Mark the location of the column relative to the pedestal. Remove column-pedestal bolts (Item 70D) and disengage column (Item 91) from pedestal.
- 13A) *Optional vapor seal only.* Remove screws and washers (Items 91F, 91G) and remove Carbon vapor seal ring from the flange. Remove vapor seal (Item 91D) and O-rings (Items 91H, 91I).

- 14) Compress and remove bearing snap ring (Item 12B). Slide bearing holder (Item 12) and bearing (Item 18) from pedestal. Use an arbor press or equivalent to remove bearing from bearing holder.
- 15) Remove vapor shield (Item 91B) from pedestal.

ASSEMBLY - VERTICAL 5530 SERIES

- 1) Clean and inspect all items prior to assembling. New gaskets and O-rings are recommended upon re-assembly.
 - 2) Press bearing (Item 18) onto bearing holder (Item 12) and slide into pedestal bore. Secure with snap ring (Item 12B).
 - 3) Install vapor shield (Item 91B) in its respective groove in the pedestal. Be sure it is properly seated.
 - 4) Insert sleeve bearing (Item 93B) into the casing cover (Item 11). Line up grooves in bearing and cover and insert pin (Item 93D) with notched end facing outward. Install snap ring (Item 93C) into groove with the flat adjacent to the notch in the pin. Inspect internal bearing flush hole which runs from face of cover to the I.D. of the sleeve bearing. Be sure hole is clear.
 - 5) Install column O-ring (Item 91A) in the column (Item 91) and install the cover/bearing assembly with the cover nuts (Item 11B). Line up with disassembly marks to original orientation.
- NOTE:** FOR STANDARD CONSTRUCTION, COMPLETE ASSEMBLY BY FOLLOWING STEPS 6 THROUGH 14. FOR OPTIONAL VAPOR SEAL CONSTRUCTION, COMPLETE ASSEMBLY BY FOLLOWING STEPS 6A THROUGH 17A.
- 6) Install column/cover assembly to the pedestal (Item 81) with the column-pedestal screws (Item 70A). Line up with disassembly marks to original orientation.
 - 7) Install impeller O-ring (Item 2B) in the impeller and thread impeller onto pump shaft (Item 6). Be sure the impeller hub is bottomed on the shaft shoulder.
 - 8) Turn cover/column/pedestal assembly into the vertical position resting on the motor end of the pedestal. Lubricate the section of shaft

in contact with the vapor shield (Item 91B) with a light coating of grease for ease of installation. Slide the shaft/impeller assembly through the cover, column, pedestal and bearing holder until the back of the impeller rests on the cover.

- 9) Thread the lock-collar (Item 66) onto the shaft threads. Hand tighten only, as the impeller clearance must be set after the pump is reinstalled.
- 10) Install the cover O-ring (Item 73), casing (Item 1) and casing hardware (Items 1C, 1D, 1E).
- 11) Lay pump assembly on its side and reinstall coupling half and key.
- 12) Reinstall pump into position per the pump installation procedure found on page 3.
- 13) Set impeller clearance per the impeller setting procedure found on page 9.
- 14) Reinstall the motor and recheck for rotation as per the procedure found on page 4.

NOTE: THE FOLLOWING IS FOR COMPLETION OF THE PUMP ASSEMBLY WITH THE OPTIONAL VAPOR SEAL.

- 6A) Install impeller O-ring (Item 2B) in the impeller and thread impeller onto pump shaft (Item 6). Be sure the impeller hub is bottomed on the shaft shoulder.
- 7A) Lubricate the back face of the vapor seal cavity with a light coating of grease as shown in figure 7A1. Install seal plate O-ring (Item 91I) in the vapor seal flange (Item 91C) and temporarily clamp into position.
- 8A) Slide the shaft/impeller assembly through the column/ cover/seal-plate assembly until the back of the impeller is against the face of the cover.
- 9A) Install the cover O-ring (Item 73), casing (Item 1) and casing hardware (Items 1C, 1D, 1E).
- 10A) Turn the casing/cover/column assembly into the vertical position resting on the casing suction flange. Block this assembly to keep from tilting.
- 11A) Slide the vapor seal (Item 91D) over the shaft and gradually push it into position in the vapor seal cavity of the vapor seal flange. The lip of the vapor seal should be slightly protruding above the face of the vapor seal flange.

- 12A) Install the seal ring O-ring (Item 91H), lightly coat the face of the vapor seal ring (Item 91E) with a thin film of grease or oil and secure into position with the mounting screws and washers (Items 91E, 91F). Gradually cross tighten screws to assure seal ring is perpendicular to shaft. Torque screws to 10 in-lbs. Max.
- 13A) Lubricate the section of shaft in contact with the vapor shield (Item 91B) with a light coating of grease for ease of installation. Remove temporary clamp holding vapor seal flange and install pedestal assembly on top of column assembly. Be sure pilots are correctly engaged and fasten with column-pedestal screws (Item 70A).
- 14A) Thread the lock-collar (Item 66) onto the shaft threads. Hand tighten only, as the impeller clearance must be set after the pump is reinstalled.
- 15A) Reinstall pump into position per the pump installation procedure found on page 3.
- 16A) Set impeller clearance per the impeller setting procedure found on page 9.
- 17A) Reinstall the motor and recheck for rotation as per the procedure found on page 4.

- 5) Place a dial indicator on the end of the shaft or coupling flange. Rotate the collar clockwise, raising the shaft to the clearance specified in table below.

NOTE: For quick field adjustment, rotate the collar 90° clockwise, while securing the shaft.

IMPELLER DIAMETER	IMPELLER CLEARANCE
UP TO 8"	.015"
8" TO 10"	.020"
10" TO 13"	.025"

- 6) Re-lock adjusting collar clamping screw (Item 66).
- 7) Tighten set screw(s) (Item 12A).
- 8) Rotate the shaft by hand while pushing down on the shaft or coupling half to insure that there is no binding or rubbing of parts.
- 9) Lower motor coupling half to correct position and retighten.
- 10) Replace coupling guard.

IMPELLER ADJUSTMENT FOR 5530 SERIES

The 5530 series design permits adjustment of the impeller clearance between the pump casing wall and the impeller face. The pump impeller is adjusted at the factory during assembly and should not require further adjustment upon installation.

Impeller adjustment will be required when a drop in head and/or capacity indicates a change in clearance. Impeller adjustment will also be necessary if the pump was disassembled/reassembled and/or if parts were replaced. Refer to the following table for recommended clearance when adjusting impeller on horizontal pumps.

- 1) Loosen motor coupling half and raise approximately 1/4" to allow for axial travel of the pump shaft.
- 2) Loosen bearing cap set screw(s) (Item 12A).
- 3) Loosen clamping screw in adjusting collar (Item 66).
- 4) Slowly rotate adjusting collar counterclockwise while pushing down on the pump shaft, rotate the shaft until you feel the impeller touch the casing face.

5530 SERIES SECTIONAL DRAWING

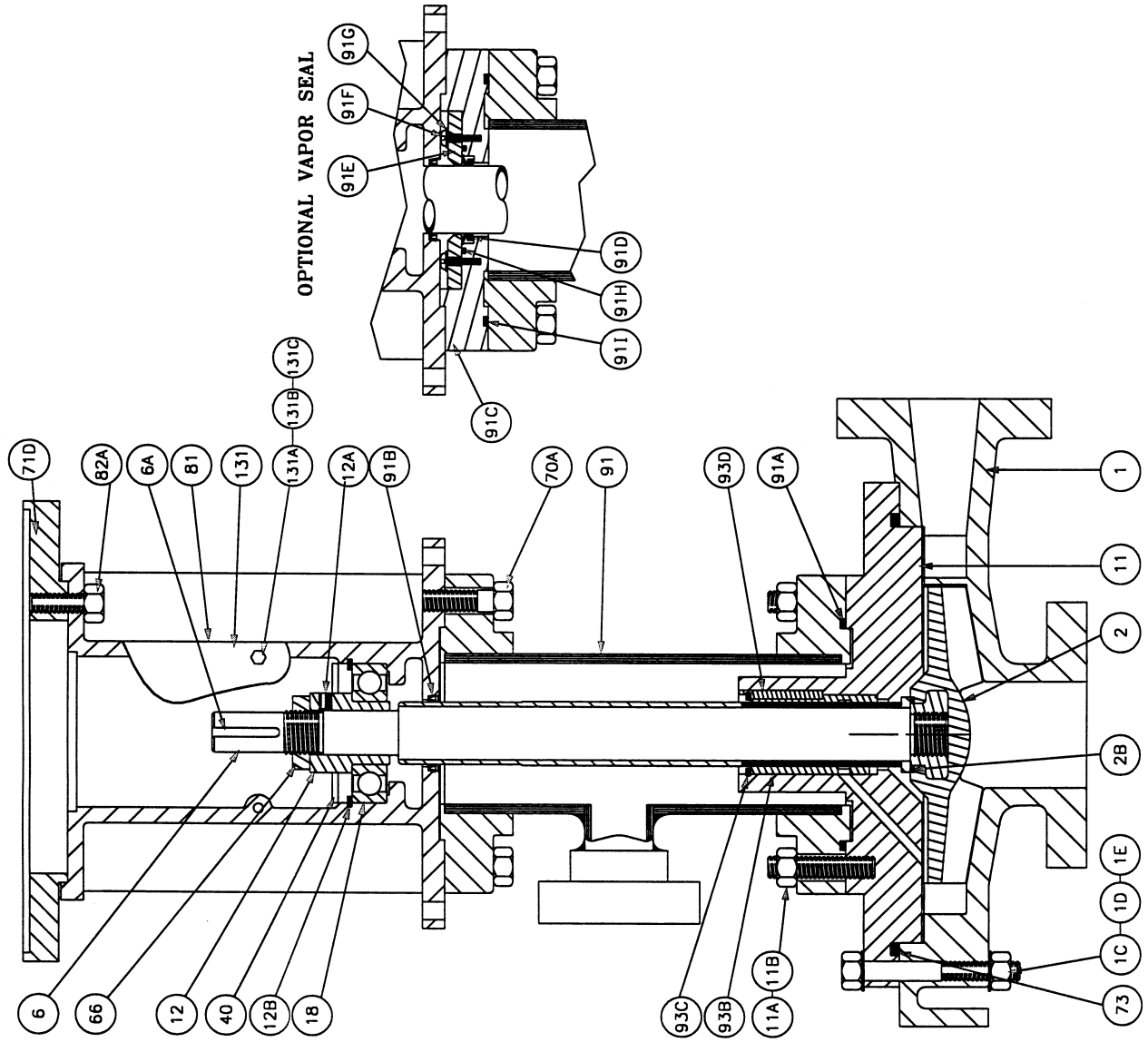

PART#	DESCRIPTION	REQ'D
1	CASING	1
1C	NUT, CASING	6-16
1D	BOLT, CASING	6-16
1E	WASHER, CASING	12-32
2	IMPELLER	1
2B	O-RING, IMPELLER	1
6	SHAFT	1
6A	KEY, COUPLING	1
11	COVER, CASING	1
11A	STUD, COLUMN-COVER	4-8
11B	NUT, COLUMN-COVER	4-8
12	BEARING HOLDER	1
12A	SET SCREW, BEARING HOLDER	1-2
12B	SNAP RING, BEARING	1
18	BALL BEARING	1
40	SLINGER	1
66	THREADED COLLAR	1
70A	SCREW, COLUMN-PEDESTAL	4
71D	ADAPTOR, MOTOR	1
73	O-RING, COVER	1
81	PEDESTAL	1
82A	SCREW, PEDESTAL-MOTOR ADAPTOR	4
91	COLUMN	1
91A	O-RING, COLUMN	1
91B	VAPOR SHIELD	1
91C	FLANGE, VAPOR SEAL	1
91D	VAPOR SEAL	1
91E	VAPOR SEAL, RING	1
91F	SCREW, CARBON	4
91G	WASHER, CARBON	4
91H	O-RING, SEAL RING	1
91I	O-RING, SEAL PLATE	1
93B	SLEEVE BEARING, COVER	1
93C	SNAP RING, SLEEVE BEARING, COVER	1
93D	PIN, COVER	1
131	COUPLING GUARD	1
131A	SCREW, COUPLING GUARD	2
131B	NUT, COUPLING GUARD	2
131C	LOCKWASHER, COUPLING GUARD	2

5530 SERIES OUTLINE DRAWING

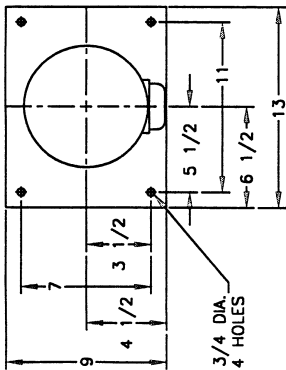

MOTOR	RPM	HP	HZ	VOLTS
143TC/145TC	22			
182TC/184TC	26	1/4		
213TC/215TC	30			
254TC/256TC	33	3/8		
284TC/286TC	35	1/4		
324TSC/326TSC	39			

MOTOR FRAME	C
143TC/145TC	22
182TC/184TC	26
213TC/215TC	30
254TC/256TC	33
284TC/286TC	35
324TSC/326TSC	39

FLANGE	O.D.	THICK.	B.C.	# OF HOLES	ISZ OF HOLES
1	4 1/4	7/8	3 1/8	4	5/8
1 1/2	5	1 1/8	3 7/8	4	5/8
2	6	1 1/8	4 3/4	4	3/4
3	7 1/2	1 3/16	6	4	3/4
4	9	1 1/4	7 1/2	8	3/4
4(1)	9	(1)	7 1/2	8	(2)
6(1)	11	(1)	9 1/2	8	(3)

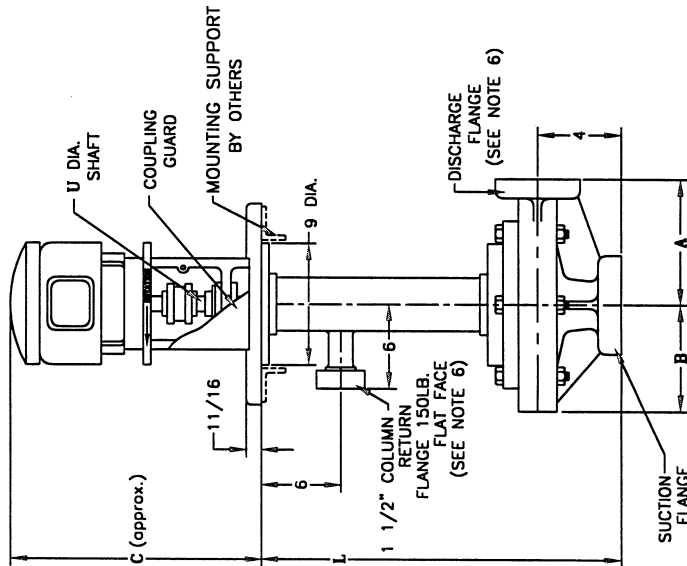

PUMP SIZE	SUCT.	DISCH.	A	B	O.D.	U	KEYWAY	WEIGHT APPROX.**
1X1 1/2X6	1 1/2	1	6 1/2	5 1/4	10 1/8	.875	3/16	-
1 1/2X3X6	3	1 1/2	6 1/2	5 1/4	10 1/8	.875	3/16	-
2X3X6	3	2	6 1/2	5 1/4	10 1/8	.875	3/16	-
1X1 1/2XB	1 1/2	1	6 1/2	5 1/4	10 1/8	.875	3/16	-
1 1/2X3XB	3	1 1/2	8 1/2	8 1/4	14 1/4	1.125	1/4	-
2X3XB	3	2	9 1/2	8 1/4	14 1/4	1.125	1/4	-
3X4XB	4	3	11	8 1/4	14 1/4	1.125	1/4	-
1X2X10	2	1	8 1/2	8 1/4	14 1/4	1.125	1/4	-
1 1/2X3X10	3	1 1/2	8 1/2	8 1/4	14 1/4	1.125	1/4	-
2X3X10	3	2	9 1/2	8 1/4	17 1/4	1.125	1/4	-
3X4X10	4	3	11	8 1/4	17 1/4	1.125	1/4	-
4X4X10	4(1)	4	12 1/2	8 1/4	17 1/4	1.125	1/4	-
4X6X10	6(1)	4	13 1/2	10	22 1/4	1.125	1/4	-
2X3X13	3	2	11 1/2	10	20 1/2	1.125	1/4	-
3X4X13	4	3	12 1/2	10	20 1/2	1.125	1/4	-
4X6X13	6(1)	4	13 1/2	10	22 1/4	1.125	1/4	-

NO.	SETTING
1	18°(1'-6")
2	36°(3'-0")
-	-

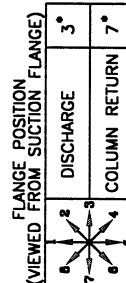

*-UNLESS SPECIFIED FLANGES WILL BE ORIENTED AS SHOWN

CUSTOMER
CUST. P.O.#
TAG:
FYBROC S/N

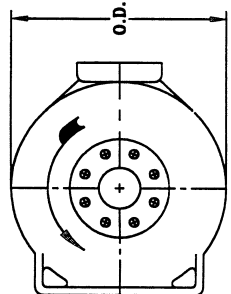

- NOTES:
- THREADED SUCTION CONNECTION.
 - 5/8-11 TAPPED HOLES 1" DEEP.
 - 3/4-10 TAPPED HOLES 1" DEEP.
 - ALL DIMENSIONS IN INCHES
 - FLANGES ARE 150LB. FLAT FACE FACING SUCTION FLANGE. ROTATION IS COUNTERCLOCKWISE
 - DO NOT OPERATE IN REVERSE ROTATION. WARNING: FLANGE CAN BE ORIENTED IN INCREMENTS OF 45°

**-L=36", LESS MOTOR

OPERATIONAL START-UP CHECKLIST

- Pump mount is level and plumb.
- Mounting bolts are tight.
- Motor mounting bolts tight.
- Suction and discharge connections secure.
- Flush piping installed (if required).
- Electrical connections secure and covered.
- Ensure that coupling sleeve is disengaged.
- Jog motor/Check rotation.
- Turn pump shaft by hand, ensure that it does not bind.
- Install coupling sleeve.
- Ensure that all guards are in place.
- Ensure bearing flush is on (if required).
- Suction valve is open. Discharge valve is slightly open.
- Ensure that pump is filled with liquid.
- Start pump and open discharge valve to desired flow rate.
- Check flush water flow and pressure (if required).
- Check for excessive vibration and bearing temperature.

NOTES

NOTES

NOTES



Fybroc Division

700 Emlen Way, Telford, PA 18969

TOLL-FREE: 1-800-FYBROC-1, Phone: (215) 723-8155, Fax: (215) 723-2197

E-Mail: sales@fybroc.com, Web Site: www.fybroc.com