



ITT

B45-70HB

Commercial Water

Goulds Pumps

45HB, 70HB High Pressure
Centrifugal Booster Pump



FEATURES

- **Multi-Stage Design:** This configuration provides a steady, quiet and vibration-free operation for years of trouble-free service.
- **Impellers and Diffusers:** Glass filled thermoplastic. Precision molded for high efficiencies.
- **Bowls:** Constructed with 300 series stainless steel. Rabbet lock for positive alignment – no gaskets required.
- **Mechanical Seal:** Carbon/ceramic faces. BUNA elastomers 300 series stainless steel metal parts.
- **Motor:** Close-coupled design. Ball bearings carry all radial/axial thrust loads. Designed for continuous operation. All ratings are within working limits of the motor.

WARNING: This is a booster pump. It has no lift capability. DO NOT RUN DRY. DO NOT DEADHEAD.

Goulds Pumps is ISO 9001 Registered.

Engineered for life

APPLICATIONS

Wide variety of industrial, commercial and agricultural uses, especially:

- High rise buildings
- Multiple dwelling buildings
- Reverse osmosis systems
- High pressure cleaning
- Spraying systems
- Booster service

SPECIFICATIONS

Pump

- Capacities: to 100 GPM
- Heads: to 760 feet.
- Pipe connections: Suction 2" NPT, Discharge 2" NPT.
- Temperature: 160°F (71°C) maximum.
- Inlet pressure: 100 PSI maximum.
- Rotation: right hand, i.e., clockwise when viewed from motor end.

Motor

- Open drip-proof or TEFC enclosure 60 Hz, 3500 RPM. Threaded shaft extension.
- Single phase: 3 HP 115/208–230 V
5 HP 208–230 V
7½ HP 208–230 V.
- Three phase: 3–10 HP 208–230/460 V.

COMPONENTS

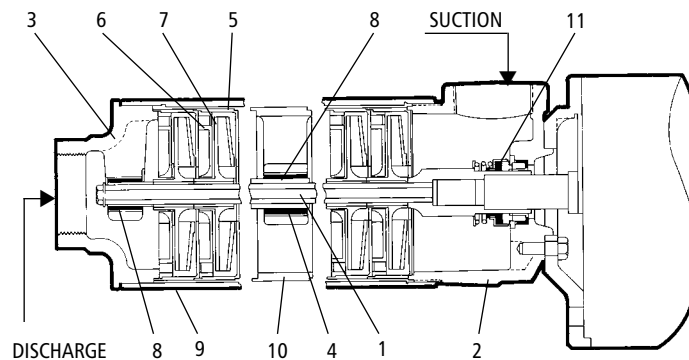

Item No.	Description	Material
1	Hex shaft and coupling	300 series stainless steel
2	Suction housing	Brass (ASTM B584)
3	Discharge head	Brass (ASTM B584)
4	Shaft sleeve	300 series stainless steel
5	Bowl	300 series stainless steel
6	Diffuser	Glass-filled thermoplastic
7	Impeller	Glass-filled thermoplastic
8	Marine bearing	BUNA
9	Casing	300 series stainless steel
10	Intermediate bearing spider	Brass (ASTM B584)
11	Mechanical seal	Carbon/ceramic faces, BUNA elastomers, 300 series stainless steel metal parts.

MODELS

Order No.	HP	No. of Stages	Phase	Enclosure	Frame	W.E.L.	Weight (lbs.)
45HB13012	3	3	1	ODP	182	11½	88
45HB23012	3	2	1	TEFC	184	10¾	101
45HB13035	3	3	3	ODP	145	11½	59
45HB23035	3	2	3	TEFC	182	10¾	83
45HB15013	5	5	1	ODP	184	13¾	100
45HB25013	5	4	1	TEFC	213	12¾	147
45HB15035	5	5	3	ODP	182	13¾	80
45HB25035	5	4	3	TEFC	184	12¾	99
45HB17513	7½	7	1	ODP	213	16¼	169
45HB17535	7½	7	3	ODP	184	16¼	103
45HB27535	7½	6	3	TEFC	213	15¾	150
45HB11135	10	10	3	ODP	213	21½	155
45HB21135	10	8	3	TEFC	215	17½	190
70HB13012	3	2	1	ODP	182	10¾	86
70HB23012	3	2	1	TEFC	184	10¾	99
70HB13035	3	2	3	ODP	145	10¾	57
70HB23035	3	2	3	TEFC	182	10¾	81
70HB15013	5	4	1	ODP	184	12¾	98
70HB25013	5	3	1	TEFC	213	11½	145
70HB15035	5	4	3	ODP	182	12¾	78
70HB25035	5	3	3	TEFC	184	11½	97
70HB17513	7½	6	1	ODP	213	15¾	170
70HB17535	7½	6	3	ODP	184	15¾	101
70HB27535	7½	5	3	TEFC	213	13¾	148
70HB11135	10	9	3	ODP	213	20¼	153
70HB21135	10	7	3	TEFC	215	17½	188

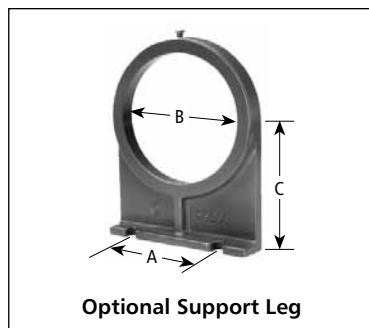

OPTIONAL SUPPORT LEG – dimensions (in inches)

Model	Frame	A	B	C
AM200	182/184	4⅞	5¾	4½
AM201	213/215	4⅞	5¾	5¼

NOTE: Support leg is not required for 145 frame motors.

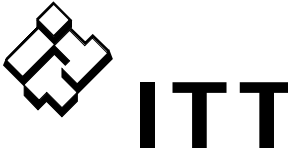

DIMENSIONS – determined by motor (in inches)

Frame	A	AB	B	BG	C	D	E	F	G	H	O
145	6½	5¼	5 ¹⁵ / ₁₆	4 ⁷ / ₈	6	3½	2¾	2	⅝	1 ¹ / ₃₂	6 ³ / ₈
182 ¹ / ₁₈₄	8½	6	6½	5¾	9 ⁹ / ₁₆	4½	3¾	2¼	⅝	1 ³ / ₃₂	8½
213 ¹ / ₂₁₅	9½	7 ³ / ₈	8	7¼	9 ⁷ / ₁₆	5¼	4¼	2¾	⅞	1 ³ / ₃₂	10 ³ / ₁₆

(All dimensions are in inches. Do not use for construction purposes.)

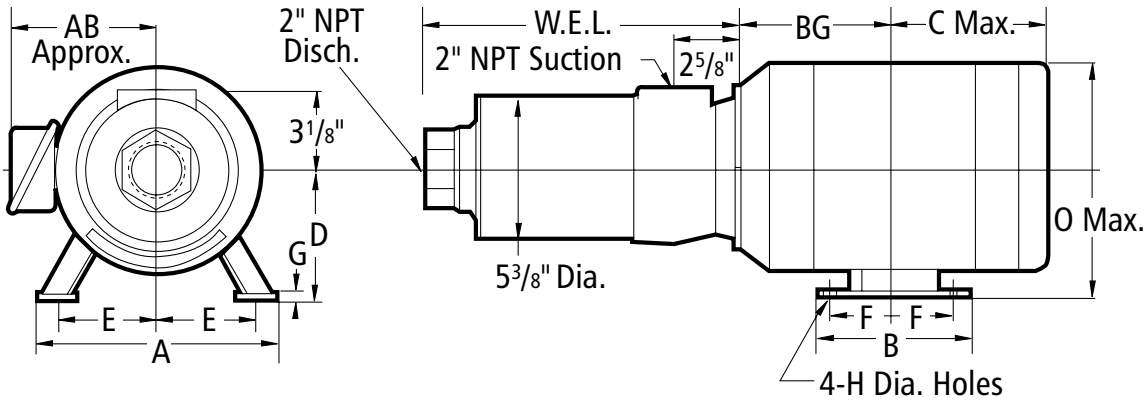

ITT
 2881 East Bayard Street, Seneca Falls, NY 13148
 Phone: (315) 568-7123 • Fax: (315) 568-7973
www.goulds.com

Goulds Pumps is a registered trademark of ITT Corporation. ITT, the Engineered Blocks Symbol and Engineered for Life are registered trademarks of ITT Manufacturing Enterprises, Inc.

Copyright © 2009 ITT Corporation B45-70HB September, 2009 Printed in U.S.A.
 SPECIFICATIONS ARE SUBJECT TO CHANGE WITHOUT NOTICE.