

# MOS Series Pump Protection / Monitoring Modules

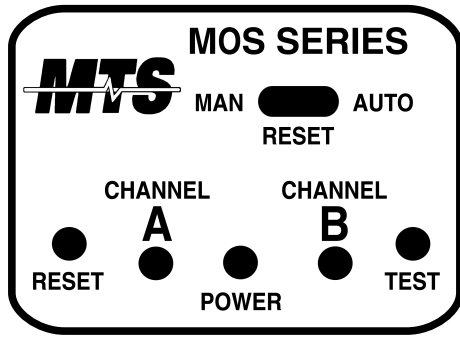

**Base Part Numbers:** MOS-1P, MOS-1PE, MOS-1PR, MSS-2P, MSS-2PE, MSS-2PR, MTT-2P, MRS-1P, MRS-1PE, MRR-2P, MRT-1P



## Model Variations (Channel Usage)

The MOS channels (A and B) may be used independently in any combination, as shown in the following table.

Model	Channel A	Channel B
MOS-1P	100K resistance probe (seal-fail)	NC Klixon™ (thermal)
MOS-1PE	NC seal chamber float switch (seal-fail)	NC Klixon™ (thermal)
MOS-1PR	33k parallel resistor with 100k resistance probe (seal-fail)	NC Klixon™ (thermal)
MSS-2P	100K resistance probe (seal-fail)	100K resistance probe (seal-fail)
MSS-2PE	NC seal chamber float switch (seal-fail)	NC seal chamber float switch (seal-fail)
MSS-2PR	33k parallel resistor with 100k resistance probe (seal-fail)	33k parallel resistor with 100k resistance probe (seal-fail)
MTT-2P	Thermistor DIN44082/01D463 (thermal)	Thermistor DIN44082/01D463 (thermal)
MRS-1P	100K resistance probe (seal-fail)	Pt100 RTD (thermal)
MRS-1PE	NC seal chamber float switch (seal-fail)	Pt100 RTD (thermal)
MRR-2P	Pt100 RTD (thermal)	Pt100 RTD (thermal)
MRT-1P	Thermistor DIN44082/01D463 (thermal)	Pt100 RTD (thermal)

## Overview

The MOS Series pump protection and monitoring modules are designed to provide a low-cost, flexible solution for protecting most brands of submersible sewage pumps against thermal and seal-failure conditions. Separate LED indication and relay contact outputs for each function are included. Flexible model options enable protection of any submersible sewage pump with heat sensor and/or seal-failure sensing devices installed. The MOS Series may be powered by 24 to 240 VAC, 50/60 Hz with no modifications. Standard models are available for monitoring via resistance probes, seal-failure float switches, Klixon thermal switches, RTDs and thermistors. Custom modules may also be factory configured.

## Operation Description

The MOS Series combines detection circuits for both motor and bearing over-temperature and seal-failure in a single plug-in unit. In an alert condition, the appropriate LED is illuminated and relay contacts associated with the condition toggle. Thus a load, such as the motor contactor, may be turned off, or a warning light might be turned on. Upon occurrence of the first alarm condition, the proper LED will illuminate a steady alarm indication. If the alarm is cleared automatically, the LED will then begin to flash, so that the operator will know that one or more alarm occurrences has been detected, and automatically cleared.

A low voltage supply provides power to the over-temperature and seal-failure monitoring circuits which control relay outputs based on instructions contained in a microprocessor. The microprocessor circuitry includes power-on-reset and oscillator start-up timers as well as an independent watchdog timer to ensure reliable operation. Both hardware and software filtering is implemented on the sensor inputs for reliable signal integrity in noisy environments.

A Test push button simulates faults on both sensor channels, and a Reset push button clears the alert indicators after (1) The Test push button has been depressed, or (2) an actual alert has been corrected. The Reset push button performs a "hard" microprocessor reset.

To prevent dislodgement of the module it is designed to be mounted in an industrial type 12-pin socket with hold down clip.

## Common Features (All Models)

- ◆ **Auto/Manual Reset:** Channels that monitor temperature can be set for Manual or Auto reset after experiencing an alarm condition. (Seal failures automatically reset when the alarm condition is removed although the LED continues to flash until reset.)
- ◆ **Reset Push-button:** The reset button is used to reset all alarm conditions and clear flashing LED states.
- ◆ **Test Push-button:** The test button simulates an alarm condition in both channels until released. NOTE: In many cases this will cause the pump to stop because of the simulated high temperature condition.

### Technical Specifications

### Mechanical

Measurement Principle	Current sensing.
Environment	-40 to 55 °C ( -40 to 131 °F )
Supply Voltage	24 to 240 VAC, 50-60 Hz. / 24-48 VDC
Power Consumption	24 VAC - 50/60 Hz 1.7 VA 120 VAC - 50/60 Hz 1.9 VA 240 VAC - 50/60 Hz 2.4 VA 24 VDC 1.4 Watts
Relay Contact Rating	NEMA B300 Pilot Duty, 1/6th HP, 3A @240VAC; Form C
Sensor Voltage	Varies with resistance. Not to exceed 10 VDC±2%
LED States (Both Channels)	GREEN: no fault RED: thermal fault AMBER: seal-fail fault FLASHING: fault automatically cleared
Contact States	N.O. contact closes on fault condition or on loss of supply power.

Model	Channel A		Channel B	
	Fault	Timing	Fault	Timing
MOS-1P	R < 120k (seal-fail)	45 sec. or 3 15-sec. events in 24 hours	Klixon™ open (thermal)	7 sec. event
MOS-1PE	Float switch opens (seal-fail)	45 sec. or 3 15-sec. events in 24 hours	Klixon™ open (thermal)	7 sec. event
MOS-1PR	R < 26k or R > 40k (seal-fail)	45 sec. or 3 15-sec. events in 24 hours	Klixon™ open (thermal)	7 sec. event
MSS-2P	R < 120k (seal-fail)	45 sec. or 3 15-sec. events in 24 hours	R < 120k (seal-fail)	45 sec. or 3 15-sec. events in 24 hours
MSS-2PE	Float switch opens (seal-fail)	45 sec. or 3 15-sec. events in 24 hours	Float switch opens (seal-fail)	45 sec. or 3 15-sec. events in 24 hours
MSS-2PR	R < 26k or R > 40k (seal-fail)	45 sec. or 3 15-sec. events in 24 hours	R < 26k or R > 40k (seal-fail)	45 sec. or 3 15-sec. events in 24 hours
MTT-2P	R > 4k 130°C nom. (thermal)	7 second event	R > 4k 130°C nom. (thermal)	7 sec. event
MRS-1P	R < 120k (seal-fail)	45 sec. or 3 15-sec. events in 24 hours	R > 150 130 °C nom. (thermal)	7 sec. event
MRS-1PE	Float switch opens (seal-fail)	45 sec. or 3 15-sec. events in 24 hours	R > 150 130 °C nom. (thermal)	7 sec. event
MRR-2P	R > 150 130 °C nom. (thermal)	7 sec. event	R > 150 130 °C nom. (thermal)	7 sec. event
MRT-1P	R > 4k 130°C nom. (thermal)	7 second event	R > 150 130 °C nom. (thermal)	7 sec. event

**NOTE:** Timing values are nominal. Hardware and digital filtering will affect absolute response times by as much as 3 seconds total.

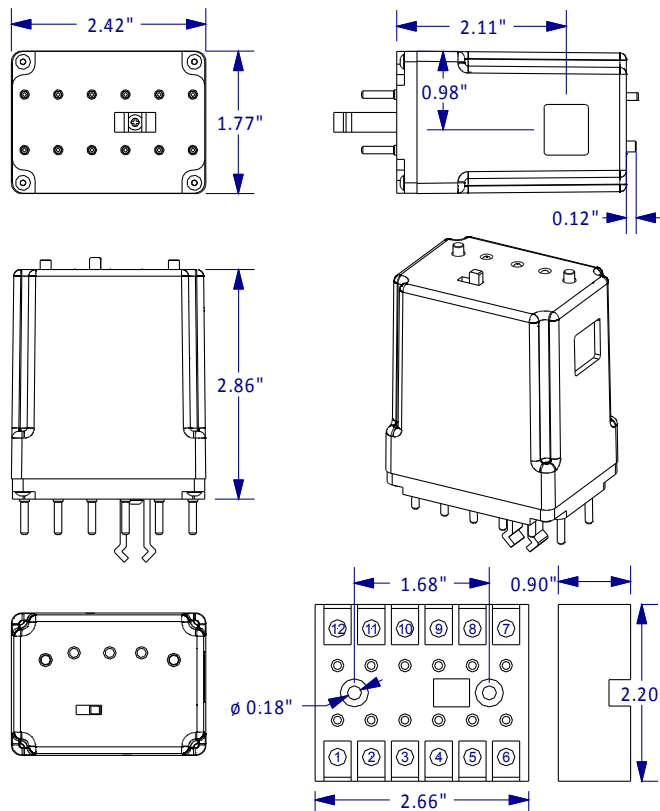

### Electrical Wiring

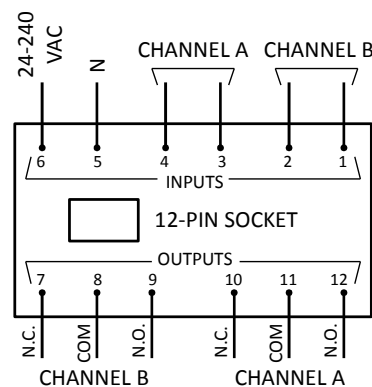

\* On 1-wire seal-fail circuits attach Pin 4 to COMMON GROUND point with PUMP SAFETY GROUND WIRE.

**NOTE:** N.O. contact closes on fault or loss of supply power.



# MOS Series Pump Protection / Monitoring Modules

## MOS-1PB Model Addendum



**Base Part Numbers:** MOS-1PB

**Suffixes:** -B (RS-485 Broadcasting Option), -M (Modbus™ over RS-485 Option)

### Overview

The MOS-1PB is a pump protection module designed to protect against both seal-failure and over-temperature conditions.

### Revision Level

This document applies to MOS firmware revisions 1.14 and higher.

### Model Variations (Channel Usage)

This addendum adds the following description to the Model Variations table on the MOS Series Pump Protection / Monitoring Modules base models datasheet.

Model	Channel A	Channel B
MOS-1PB	130k resistance probe with 330k parallel resistor between probes (seal-fail) plus continuous open-circuit detection	NC Klixon™ (thermal)

### Technical Specifications

This addendum adds the following model to the Technical Specifications section of the MOS Series Pump Protection / Monitoring Modules base models datasheet. The Auto/Man switch is inactive in the model. Alarm reset is described below.

Model	Channel A		Channel B	
	Fault	Timing	Fault	Timing
MOS-1PB	R < 93k (seal-fail) or R > 500k (open circuit)	45 sec. or 3 15-sec. events in 24 hours	Klixon™ open (thermal)	7 sec. event
ALARM RESET	Automatically reset when the alarm condition is removed; although, the LED continues to flash until reset.		No automatic reset. Unit can only be reset with the RESET pushbutton or via Modbus (-M models).	

# MOS Series Pump Protection / Monitoring Modules

## RS-485 Broadcasting Communication Option



**Base Part Numbers:** MOS-1P, MOS-1PE, MOS-1PR, MSS-2P, MSS-2PE, MSS-2PR, MTT-2P, MRS-1P, MRS-1PE, MRR-2P, MRT-1P  
**Suffixes:** -B (RS-485 Broadcasting Option)

### Overview

The MOS Series pump protection and monitoring modules may be optionally purchased with an RS-485 Broadcasting Communication option. Modules with this option periodically transmit an ASCII encoded data record over the RS-485 communication bus for reception by a host / monitor.

This datasheet describes the configuration and use of that option.

### Revision Level

This document applies to MOS firmware revisions 1.14 and higher.

### Broadcasting Hardware Connection

The MOS uses an RS-485 communication bus. The standard bus protocol is 19,200 baud, 8 data bits, NO parity, and one stop bit (19.2k,8,N,1).

RS-485 requires three wires -- RS485+, RS485-, and Ground. The MOS uses an RJ-11, six-wire connection to bring these signals out.

Illustration 1 shows the connections from the cable perspective.

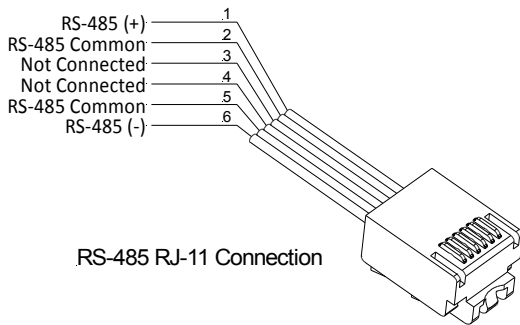

Illustration 1: Broadcasting Cable Wiring

RS-485 specifies line termination requirements, but in practice at 19,200 baud, termination is generally not required for distances less than 300 m (1500 ft.). The MOS does not incorporate internal termination.

### RS-485 Electrical Grounding

**CAUTION: Some earlier generation MOS products used pin #3 as ground. If replacing a legacy product, ensure that the system wiring is consistent with this datasheet.**

The MOS references its internal ground signal to pins #2 and #4 on the relay base. It is recommended that either pin #2 or pin #4 be referenced to chassis or panel ground. NOTE: In the case of a one-wire moisture probe, pin #4 is typically connected to panel ground. In isolated two-wire sensor configurations, either pin #2 or pin #4 should be connected to panel ground. Devices on the RS-485 bus must reference this same panel ground or be guaranteed to stay within a maximum of  $\pm 7$  volts of panel ground for proper operation. Ground voltages outside of this range will produce unpredictable results and may result in hardware damage.

In practice, all devices on the RS-485 bus should connect their zero volt potential to the panel ground. In this case only pins #1 and #6 on the

RJ-11 connector are required. If a device is floating on the bus, then pins #2 and #5 may be used to pull that device to the panel ground. These pins are common with the MOS internal ground signal. If the RS-485 bus is transmitted over long distances, then the engineer must ensure that either the remote device is guaranteed to stay within the allowed ground potential range or an isolated RS-485 repeater must be installed. Devices are commercially available. In all cases, **proper care should be taken to avoid grounding conflicts and ground loops.**

### Broadcasting Operation

Each second the MOS sends a single ASCII string out the RS-485 bus. During transmission the Green Power On LED on the MOS will momentarily blink OFF. This is a visual indication the unit is broadcasting.

### Message Format

The broadcast message ASCII encoded and readable on any terminal emulation program. Microsoft Windows™ HyperTerminal is an example.

A message packet consists of nine fields each consisting of a two-letter identifier and a value separated by a delimiter character (':'). The fields are also separated by the delimiter character (':').

All values are transmitted as ASCII encoded decimal values and are 16-bit unsigned integers in the range (0..65,535).

Field	Summary Description
FR	Firmware Revision Level
CF	Factory Configuration Type
A0	Analog Signal -- Channel B
A1	Analog Signal -- Channel A
SF	Status Flags Register
F0	Channel B Fault Counter
F1	Channel A Fault Counter
RL	Reset Counter (Lower 16-bits)
RH	Reset Counter (Upper 16-bits)

Table 1: Broadcast Message Fields

### Firmware Revision Level (FR)

The MOS firmware revision level is encoded in a decimal format. For example 109 corresponds to revision level 1.09. The most recent revision level is 1.14 (value=114).

### Factory Configuration Type (CF)

Each MOS model is assigned a unique factory configuration type. This value is broadcast for field reference.

### Analog Signal -- Channel B (A0)

The raw analog voltage signal on Channel B may be read. Interpreting

this signal requires some underlying knowledge of the MOS internal circuitry. In general, this information is not needed, but may be useful in specific troubleshooting circumstances. Consult the factory for details.

#### ***\_\_\_\_\_Analog Signal -- Channel A (A1)***

The raw analog voltage signal on Channel A may be read. Interpreting this signal requires some underlying knowledge of the MOS internal circuitry. In general, this information is not needed, but may be useful in specific troubleshooting circumstances. Consult the factory for details.

#### ***\_\_\_\_\_Status Flags Register (SF)***

The Status Flags Register uses bit encoding to track various states internally within the MOS. These bits may be used to interpret the present operating state of the MOS.

Since the information in this register is encoded in individual bits, the master must either use bit specific commands to interpret the data or use bit-wise AND operations to mask off the unused bits. Bits are labeled 0 to 15 from least significant to most significant order. That is bit #0 corresponds to 1 while bit #15 corresponds to 32,768 (decimal).

Bit	Description
4	Channel B fault condition (1 = FAULT)
5	Channel A fault condition (1 = FAULT)
6	Channel B fault condition latched (1 = FAULT has occurred)
7	Channel A fault condition latched (1 = FAULT has occurred)
12	Test switch state (1 = Test switch pressed)
13	AUTO / MAN switch state (1 = AUTO)

Latches allow an automatically cleared fault state to be recognized. Other bits have internal usage within the MOS and should be ignored.

Example: Using C language operators:

if the Status Register Flags & (1<<4) == 1, then the MOS is in a Channel B fault condition.

#### ***\_\_\_\_\_Channel B Fault Counters (F0)***

Every time the MOS senses a fault on Channel B, the fault counter is incremented by one. This counter is non-volatile and persists for the life of the product. This may be used to track an excessive number of faults in a specific installation.

#### ***\_\_\_\_\_Channel A Fault Counters (F1)***

Every time the MOS senses a fault on Channel A, the fault counter is incremented by one. This counter is non-volatile and persists for the life of the product. This may be used to track an excessive number of faults in a specific installation.

#### ***\_\_\_\_\_Reset Counters (RH:RL)***

Every time the MOS experiences a power-up from a cold start or a Manual Reset using the reset switch on the device, an internal counter tracks this reset condition. Internally this is a 32-bit counter. The lower 16-bits of this counter are presented in the field RL. The upper 16-bits are presented in the field RH. This value may be used to detect an excessive number of power failures. Total resets are given by the following formula.

$$Resets=(RH*65536)+RL$$