

## INSTRUCTIONS

### NEPTUNE CORPORATION STOP AND NOZZLE ASSEMBLIES MODEL – CS2

Model - CS2, Corporation Stop and Nozzle Assemblies are manufactured by Neptune in 1/2" NPT, 3/4" NPT and 1" NPT pipe sizes. They provide two distinct advantages over a simple tap connection into large main pipes:

1. The Nozzle may be extended for injection near the center of a large main for more effective chemical dispersion.
2. The nozzle may be withdrawn and the Corporation Stop closed without interrupting the use of the main. A typical installation style is shown below:

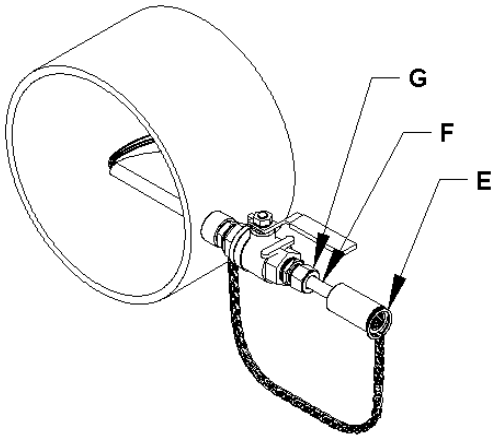

MODEL	MATERIAL OF CONSTR.	PRESS. PSI	MAXIMUM TEMP.	SIZE (INCHES) A	DIMENSIONS (INCHES)		
					B	C	D
CS2-50-316	316SS	150	250°F (121°C)	1/2 NPT	7-1/2	5-1/4	2-3/8
CS2-50-PVC	CPVC	125	100°F (37°C)	1/2 NPT	7-3/4	5-1/4	2
CS2-50-KY	KYNAR	150	200°F (93°C)	1/2 NPT	7-3/4	5-1/4	2-3/8
CS2-50-C20	C-20-Cb3	150	250°F (121°C)	1/2 NPT	7-1/2	5-1/4	2-3/8
CS2-75-316	316SS	150	250°F (121°C)	3/4 NPT	7-1/2	5-1/4	2-3/8
CS2-75-PVC	CPVC	125	100°F (37°C)	3/4 NPT	7-3/4	5-1/4	2
CS2-75-KY	KYNAR	150	200°F (93°C)	3/4 NPT	7-3/4	5-1/4	2-3/8
CS2-75-C20	C-20-Cb3	150	250°F (121°C)	3/4 NPT	7-1/2	5-1/4	2-3/8
CS2-100-316	316SS	150	250°F (121°C)	1 NPT	6-1/2	6-1/4	2-3/8
CS2-100-PVC	CPVC	125	100°F (37°C)	1 NPT	7-1/4	6-1/4	1-1/2
CS2-100-KY	KYNAR	150	200°F (93°C)	1 NPT	6-3/4	6-1/4	2
CS2-100-C20	C-20-Cb3	150	250°F (121°C)	1 NPT	6-1/2	6-1/4	2-3/8

3. Neptune specifications are shown below:

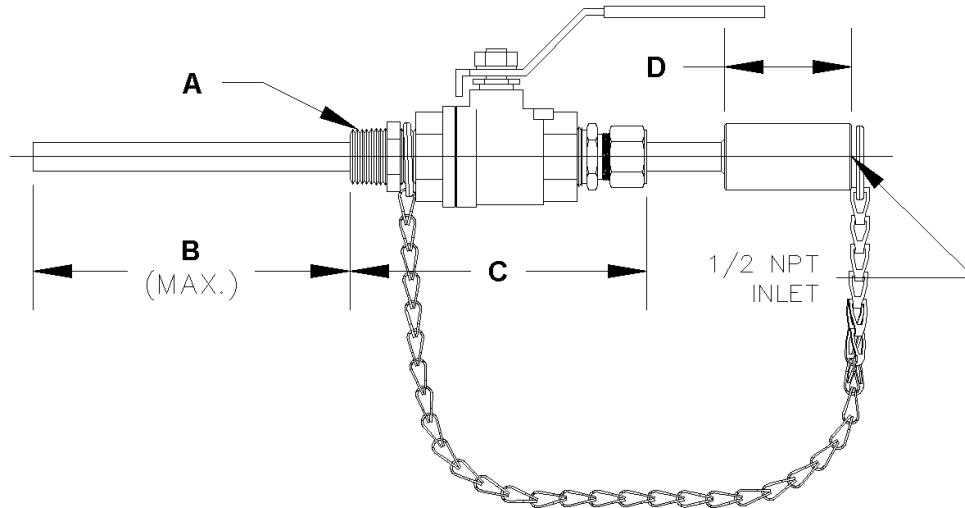

To insure proper operation, these units should be installed below the horizontal centerline of the main so that their cross section position in the main will correspond with four to eight on the face of a clock.

**WARNING** Be sure to tighten securely the fitting cap "G" after fully inserting the Nozzle Assembly.

The chain provided is used to prevent the Nozzle Assembly from being completely withdrawn and to hold it against backpressure. The Ring "E" attached to the Chain has to be installed between the inlet connection point. It must always be used. When extended its full length it will permit the Nozzle to be withdrawn enough so that the Corporation Stop may be closed, sealing the injection point. It may be necessary to loosen the fitting cap in order to slide the Nozzle "F" out through the Corporation Stop.

## INSTALLATION:

Unpack and inspect the Corporation Stop and Nozzle Assembly for damage.

### I. Main Down

- A Loosen hex nut 'G' on Corporation Stop until Nozzle Assembly 'F' will slide. Remove Nozzle Assembly.
- B Thread Corporation Stop into correct size female NPT connection in side of main.

**BE SURE that the chain connector ring is in position as shown.**

**BE CERTAIN THAT THE CORPORATION STOP IS CLOSED.**

### II. Main May Be Charged

- C Reinsert Nozzle Assembly 'F' thru hex nut until it hits closed position of Corporation Stop.
- D Connect system piping including check valve and shutoff valve as required to threaded end of Nozzle Assembly. **BE CERTAIN THAT CHAIN COLLAR 'E' IS INSTALLED NEXT TO NOZZLE ASSEMBLY WITH PIPING THRU THE CENTER.** (As shown)
- E Open Corporation Stop and slide Nozzle Assembly until it is inserted to the desired depth into the main. Tighten hex nut 'G'. **WARNING: BE SURE TO TIGHTEN HEX NUT 'G' SECURELY.**

### III. Removal

- F. Reverse procedure to remove. **BE CERTAIN TO CLOSE Corporation Stop** as soon as Nozzle Assembly is withdrawn to the length of the chain.



Manufactures of  
Metering Pumps  
Chem Feed Systems  
Portable Mixers  
Safety Faucets

P.O. Box 247 Lansdale, PA 19446  
215-699-8700  
Toll Free : 888-363-7886  
Fax : 215-699-0370  
Toll Free Fax : 800-255-4017  
Website:www.Neptune1.com