

Standard Product Capabilities

Pump solutions from a World Leader



MX Series

Injection molded magnet drive pumps

The MX Series pumps represent the latest state of the art design in plastic magnetic drive pumps. With the experience gained from previous generations of MDH pumps, the MX Series has been engineered to meet the most severe operating conditions.

When fitted with a carbon bearing, the MX will allow for periods of dry running. The patented “self radiating structure”, in addition to the existing proven non-contact principle with front and rear supported spindle, greatly improves the ability to withstand cavitation and running against a closed discharge valve.

MX Series pumps are highly recommended for use in various production processes such as filtering, spraying, washing, plating and etching in surface treatment applications.

Patented Split Volute Casing

The MX Series is the first resin magnet pump that uses a split volute pump casing that forms a vortex chamber. The volute limits the liquid getting out of the impeller and returns it to the pump, which is efficiently guided to the discharge port to enhance overall efficiency.

Patented Self-radiating structure

Through heat dispersion holes provided in fixed portions of the impeller and the magnet capsule, the liquid around the spindle and bearing is forced to circulate. Heat generated by friction can be reduced effectively, thereby preventing any thermal deformation and reducing wear.

MX utilizes standard NEMA frame motors making them easy to install. (IEC and JIS versions available)

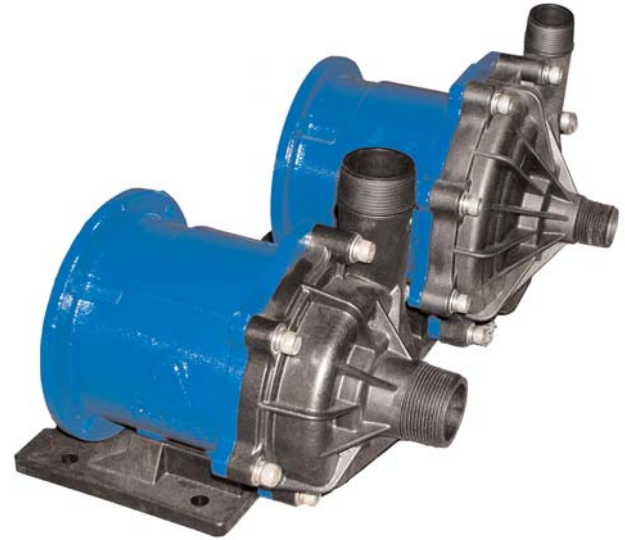

Volute casing divided into two sections



Front casing

Rear casing

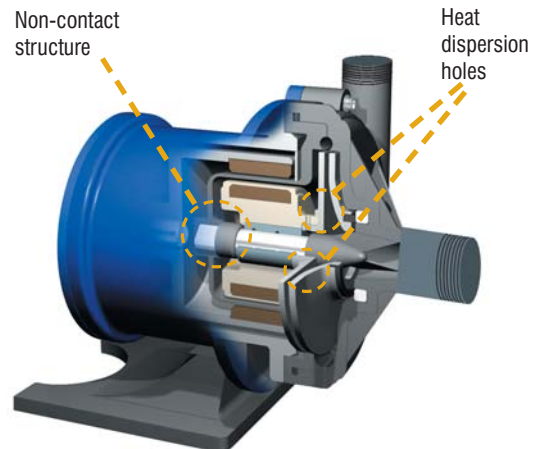

Think twice. Spec once.

PROVEN
RELIABILITY.
ADVANCED
TECHNOLOGY.





WET END MATERIALS

MX-250 to 401
MX-F250 to F401

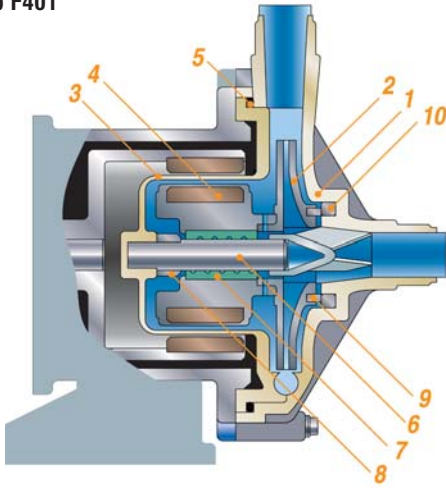

MX-402 to 403H, 100
MX-F402 to F403

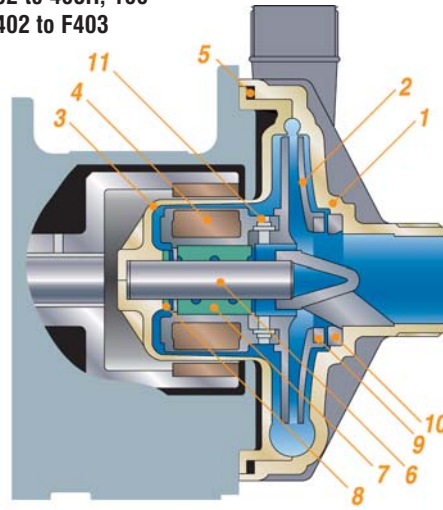

MX Materials

Model	MX-402 to F403H		
	MX-250 to 401		
Mark	AV (AE)	CV (CE)	RV (RE)
1 Front casing	GFRPP		
2 Impeller	GFRPP		
3 Rear casing	GFRPP		
4 Magnet capsule	PP		
5 O-ring	FKM ¹		
6 Spindle	High Purity Alumina Ceramic		
7 Bearing	Alumina Ceramic	Carbon	PTFE
8 Rear thrust	CFRPPS	CFRPPS ²	
9 Mouth ring	PTFE		
10 Thrust/Liner ring	Alumina Ceramic		
11 Lock pin	---	GFRPPS (only on 402 to 403H)	

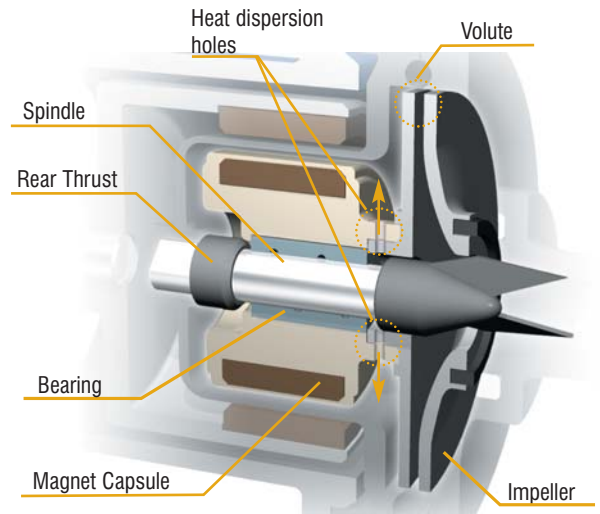

MX-F Materials

Model	MX-F402 to F403			
	MX-F250 to F401			
Mark	CFV	RFV	KKV	AFV
1 Front casing	CFRETFE			
2 Impeller	CFRETFE			
3 Rear casing	CFRETFE			
4 Magnet capsule	CFRETFE			
5 O-ring*	FKM ¹			
6 Spindle	High purity Alumina Ceramic		SiC	High purity Alumina Ceramic
7 Bearing	Carbon	PTFE	SiC	High purity Alumina Ceramic
8 Rear thrust	CFRETFE		CFRETFE ³	CFRETFE
9 Mouth ring	PTFE		SiC	PTFE
10 Thrust/Liner ring	High purity Alumina Ceramic		SiC	High purity Alumina Ceramic
11 Lock pin	CFRETFE (only on 402 & 403)			---

¹ EPDM and AFLAS® o-ring also available

² 402-403H have CFRPEEK rear thrust collars

³ F402-403H have CFRPFA rear thrust collars



PERFORMANCE CURVES

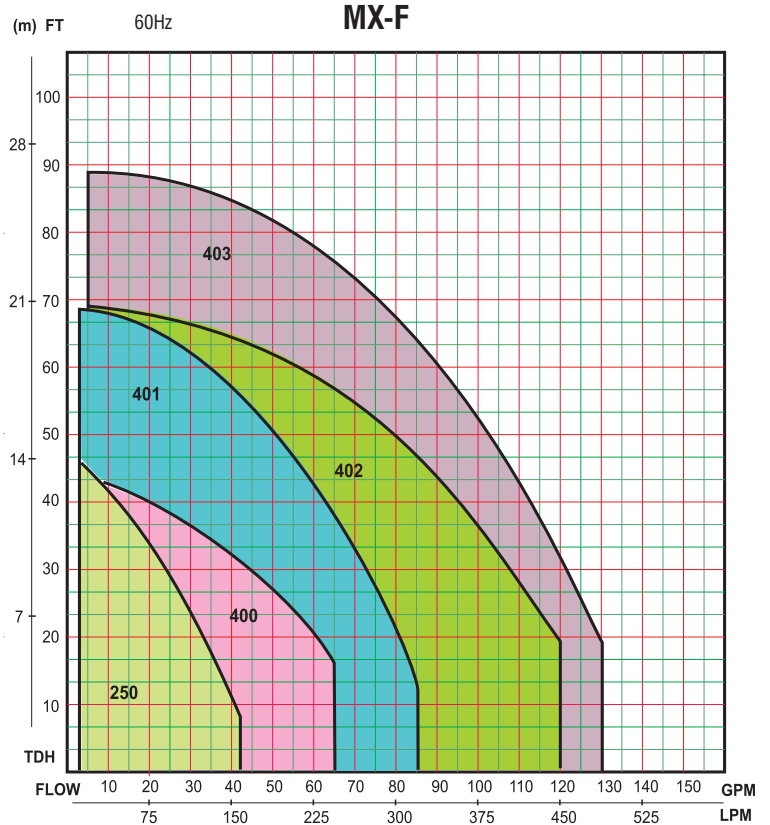
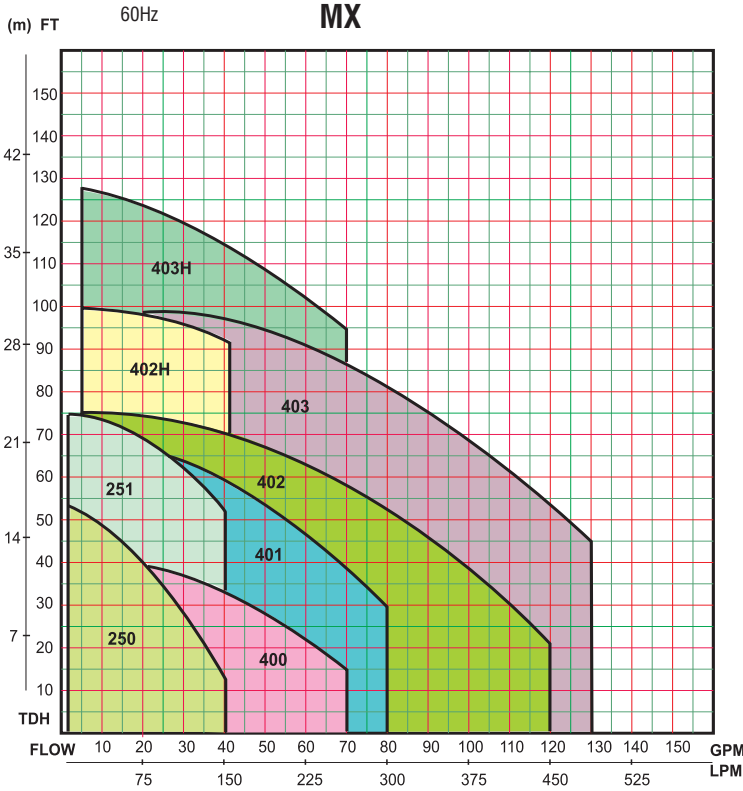

Performance based on water @ 70°F (21°C).
 Fluids with specific gravity other than 1.0 should be reviewed by the factory.

MODEL CODE



- 1 Series symbol**
 MX GFRPP casing
 MX-F CFRETFE casing

- 2 Pump size**
 250: 1" x 1" 0.5 HP
 251: 1" x 1" 1.0 HP
 400: 1.5" x 1.5" 0.75 HP
 401: 1.5" x 1.5" 1.5 HP
 402(H): 2" x 1.5" 2.0 HP
 403(H): 2" x 1.5" 3.0 HP

- 3 Materials of Bearing/Spindle/O-ring**
 MX
 CV: Carbon/Alumina ceramic/FKM (EPDM/AFLAS)
 RV: PTFE/Alumina ceramic/FKM (EPDM/AFLAS)
 AV: Alumina ceramic/Alumina ceramic/FKM (EPDM/AFLAS)
 (models MX-250 to MX-401)

- 4 Impeller mark**
 MX 5: 50 Hz
 6: 60 Hz
 7: Larger impeller

- MX -F
 CFV: High density Carbon/High purity Alumina Ceramic/FKM EPDM/AFLAS)
 RFV: PTFE/High purity alumina ceramic/FKM (EPDM/AFLAS)
 KKV: SiC/SiC/FKM (EPDM/AFLAS)
 AFV: Alumina Ceramic/Alumina Ceramic/FKM (EPDM/AFLAS)
 (models MX-F250 to F401)

- MX-F X: 50/60 Hz
 V: 50/60 Hz



Specifications

Model	Suction x Discharge (NPT)	Max. Discharge Pressure (ft)	Max Flow (GPM)	Specific Gravity	Motor Output @ 60 Hz	Weight (less motor) lbs.
MX-250	1" x 1"	53	40	1.0	0.5 HP	17.0
MX-251		75	40	1.0	1 HP	22.5
MX-400	1.5" x 1.5"	38	70	1.2	0.75 HP	13.7
		43	70			
MX-401		59	80		1.5 HP	22.5
		68	80			
MX-402	2" x 1.5"	73	107	1.2	2 HP	29.8
MX-402H		99	45	1.0		
MX-403		101	130	1.2	3 HP	32.0
MX-403H		126	70	1.0		
MX-F250	1" x 1"	48	43	1.2	0.5 HP	17.0
MX-F400	1.5" x 1.5"	43	65		0.75 HP	13.7
		34	65			
MX-F401		68	86		1.5 HP	22.5
		50	75			
MX-F402	2" x 1.5"	70	120		2 HP	29.8
MX-F403		88	130		3 HP	32.0

Dimensions

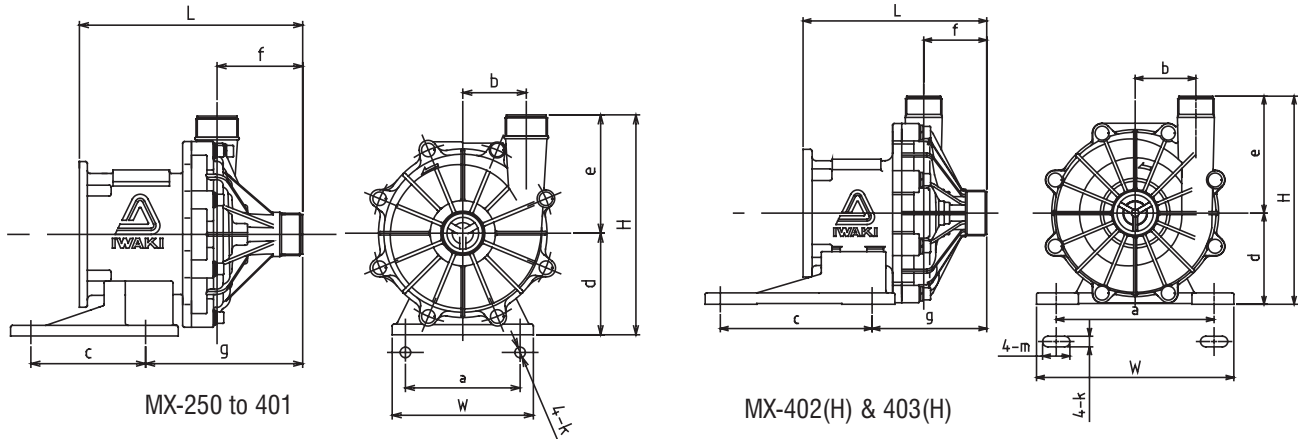

Detailed drawings available upon request.

inches (mm)

Models	W	H	L	a	b	c	d	e	f	g	k	m
MX-250	6.30 (160)	9.75 (248)	9.39 (239)	5.12 (130)	2.56 (65)	5.12 (130)	4.53 (115)	5.22 (133)	3.25 (83)	6.12 (155)	.47 (12)	---
MX-251	6.30 (160)	9.75 (248)	9.39 (239)	5.12 (130)	3.00 (76)	5.12 (130)	4.53 (115)	5.22 (133)	3.25 (83)	6.44 (164)	.47 (12)	---
MX-400	5.51 (140)	8.62 (219)	9.37 (238)	4.33 (110)	2.13 (54)	3.86 (98)	3.74 (95)	4.88 (124)	3.19 (81)	5.67 (144)	.47 (12)	---
MX-401	6.30 (160)	9.81 (249)	9.96 (253)	5.12 (130)	2.83 (72)	5.12 (130)	4.53 (115)	5.28 (134)	3.82 (97)	7.01 (178)	.47 (12)	---
MX-(F)402(H)	10.24 (260)	10.78 (274)	9.53 (242)	8.19 (208)	3.15 (80)	7.87 (200)	4.72 (120)	6.06 (154)	3.27 (83)	5.94 (151)	.55 (14)	1.42 (36)



IALT-00035.C Nov 2007