

# Standard Product Capabilities

Pump solutions from a World Leader



## SMX Series

### Versatile self-priming magnet drive pump

SMX Series of magnetically driven non-metallic pumps offer an innovative true self-priming design with no mechanical seals for years of trouble-free service.

SMX features our self-radiating bearing structure and our proven non-contact dry-run capability enabling them to withstand the rigors of abnormal operating conditions.

Utilizing an integral priming and air separation chamber, the SMX Series offer superior repeatable self-priming performance.



*Think twice. Spec once.*

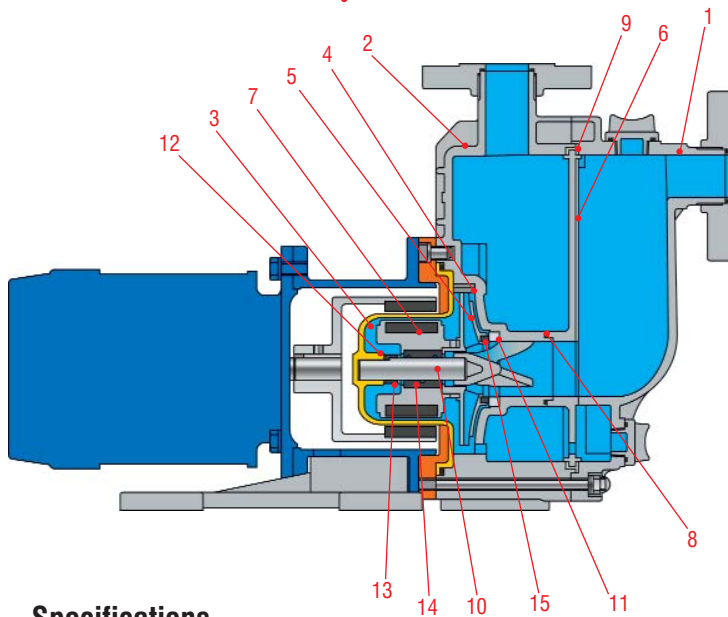

#### Wet End Materials

	Model	CA	RA	KA
1	Front case	GFRPP		
2	Rear case			
3	Rear casing			
4	Volute spacer			
5	Impeller			
6	Plate			
7	Magnet capsule	PP		
8	O-ring	FKM/EPDM		
9	Gasket			
10	Spindle	High Purity Alumina Ceramic		SiC
11	Liner ring	Alumina Ceramic		
12	Rear thrust	CFRPPS		
13	Rear thrust ring	--	Alumina Ceramic	--
14	Bearing	Carbon	PTFE	SiC
15	Mouth ring	PTFE		

#### Specifications

Model	Connections Suction x Discharge	Impeller Code	Max Capacity @60Hz (GPM)	Max Head (ft)	Min Flow Rate (GPM)	Motor (RPM)	Motor (HP)
SMX-220	1 x 1	Y	36	40	2.6	3500	1/2
SMX-221		X	45	62			1
SMX-221		Y	36	40			1
SMX-222		X	45	62			2
SMX-441	1 1/2 x 1 1/2	Y	77	59			1
SMX-442		X	91	83			2
SMX-443		X	91	83			3



**Principles of Self-Priming**

**1**

The pump is primed with liquid.

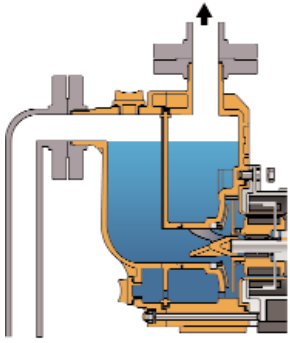

**2**

When the operation starts, liquid and gas on the suction side are taken in through the front casing A and then mixed together by the impeller. The mixture is discharged from pump chamber B and sent to the inside rear casing C, where the liquid and gas are separated from each other. The liquid remains there and proceeds in direction E, while the gas is discharged through port D. Then the liquid goes back into pump chamber B through circulation hole E, where it is mixed again with the gas on the suction side. This process is repeated until the gas on the suction side F is completely exhausted.

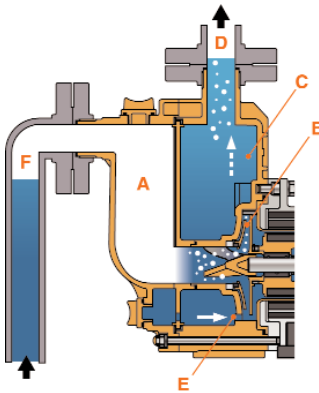

**3**

Once the gas is completely removed and the pump is filled with liquid, the SMX works as a typical centrifugal pump. Even if the pump is stopped, sufficient liquid is retained to perform the self-priming again.

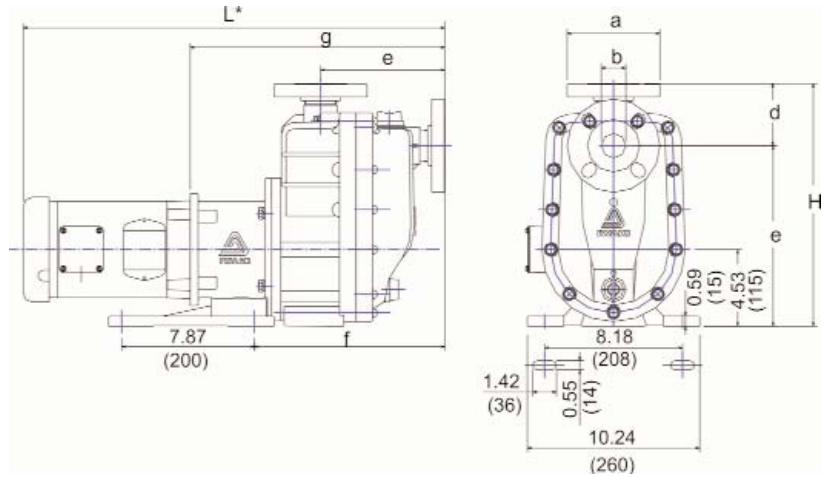
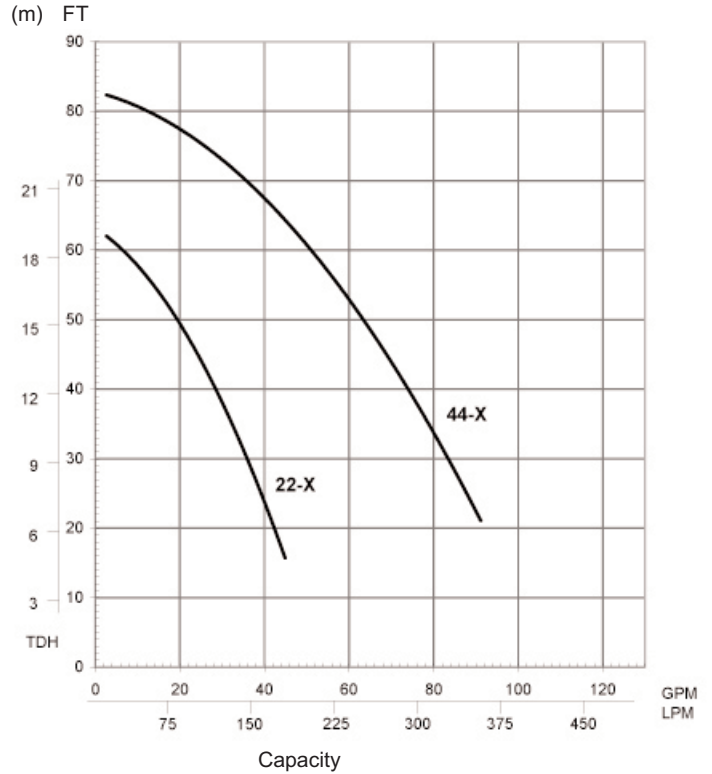
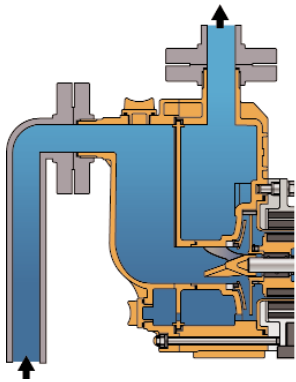

**Dimensions in inches (mm)**

Model	a	b	c	d	e	f	g	H	L*	HP/Frame
SMX-220	4.92 (125)	0.98 (25)	6.38 (162)	2.91 (74)	10.01 (255)	9.45 (240)	12.13 (308)	12.95 (329)	21.22 (539)	0.5/56C
12.60 (320)							21.77 (533)		1.0/56C	
13.07 (332)							23.89 (697)		2.0/145TC	
SMX-441	5.51 (140)	1.57 (40)	7.40 (188)	3.66 (93)	10.67 (271)	11.22 (285)	14.41 (366)	14.33 (364)	23.58 (599)	1.0/56C
14.88 (378)							25.69 (652)		2.0/145TC	
14.88 (378)							25.69 (652)		3.0/145TC	

\*Varies according to motor manufacturer

