



MODEL MOS-1P_E

OVER-TEMPERATURE AND SEAL FAILURE DETECTION RELAY



INSTALLATION AND OPERATION INSTRUCTIONS

IMPORTANT

NOTE: FOR USE WITH MOST SUBMERSIBLE PUMP MOTORS WHICH UTILIZE AN OVER-TEMPERATURE SENSOR AND A SEAL FAILURE SENSOR THAT OPEN A SET OF CONTACTS INTERNAL TO THE PUMP MOTOR WHEN AN ALERT OCCURS.

The unit should periodically be tested using the following procedure:

- A. Press the Test push button for 5 seconds. When released, both LED's will begin to flash.
- B. Press the Reset push-button for 5 seconds. If there is no Over-temperature or Seal Failure condition present, both LED's will extinguish.

Upon the occurrence of the first alarm condition, the proper LED will illuminate a steady alarm indication. If the alarm should clear, the LED will then begin to flash, so that the operator will know that at least one alarm occurrence has been detected, and cleared.

Both the over-temperature and seal failure circuits require a normally closed switch (separate contacts for each function) in the motor.

A Test push-button simulates contacts changing states (opening) in both the over-temperature and seal failure switches in the pump, and a Reset push button clears the alert indicators after (1) The Test push button has been depressed, or (2) an actual alert has been corrected.

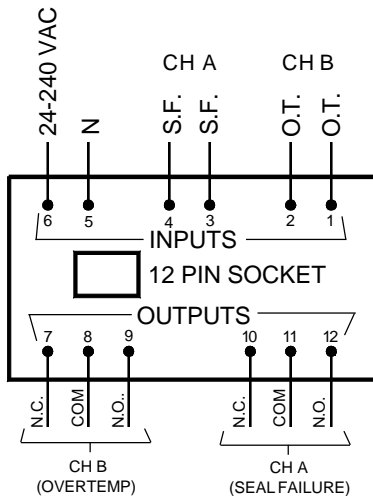

Inputs / Outputs by Pin Number

SPECIFICATIONS

| | |
|-------------------------------|---|
| Input Voltage: | 24-240 VAC, 50/60 Hz |
| Power Consumption: | 2.8 Watts Max |
| Power to Sump: | Channel A - < 2 μ A @ 5VDC Channel B - < 25 μ A @ 12VDC |
| Fusing: | Control power transformer only |
| Relay Life: | Mechanical - 50 Million Operations Electrical - 10 Million Operations @ 5 Amps (1/6 th HP), 115VAC |
| Operating Temperature: | -4° F (-20° C) to +140° F (+60° C) |

Seal Failure Trip Resistance: 120K Ohms (Nominal)

NOTE: When used on applications with Variable Frequency Drives, we recommend that the wiring from the Seal Fail and High Temp Terminals be run as twisted/shielded pair to prevent any noise spikes from being conducted into the processor.

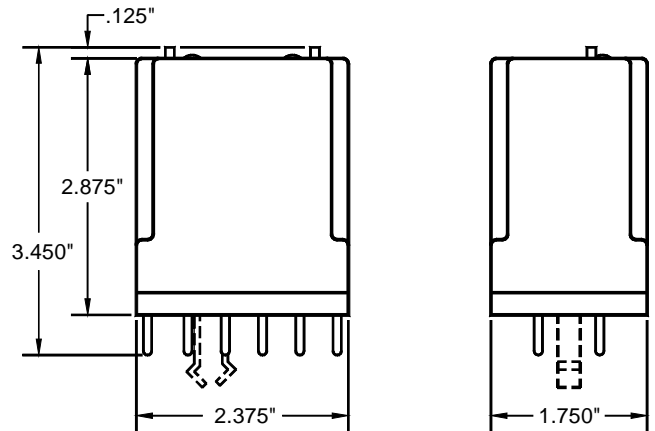

Inputs / Outputs by Pin Number

1. Over-temperature Output to N.C. Motor Temp. Switch (+12VDC)
2. Return From Motor Temperature Switch; Less Than 25 μ A
3. Return From Seal Failure Probe
4. Output to Seal Failure Probe; Under 6 Volts, < 2 microamps
5. Supply Neutral
6. 24-240 VAC (Nominal), 50 / 60 Hz
7. Normally Closed - Opens on High Temperature Fault
8. High Temperature Relay Common
9. Normally Open - Closes on High Temperature Fault
10. Normally Closed - Opens on Seal Failure Fault
11. Seal Failure Relay Common
12. Normally Open - Closes on Seal Failure Fault

Note: Relays are Electrically Held in Their "Normal" States



READ THIS FIRST!

IMPORTANT SETUP PROCEDURES

MOS-1PE Seal Fail/High Temp Relay

Upon application of power to the MOS-1PE relay, it immediately starts an internal test routine to verify correct operation. This test routine lasts for 15 seconds, after which the relay is ready to monitor the Chan A (Seal Failure) and Chan B (High Temperature) inputs. *(The output relay contacts for each channel do not change state until after the test routine is completed and the input channels have been polled.)*

(Pressing the Reset pushbutton will also initiate the internal test routine.)

After the test routine is complete, the green Power On LED and the Chan A and Chan B LED's will be illuminated. If there is no fault condition present on either input channel, both channel LED's will be illuminated Green.

The Chan A and Chan B input channels have built in time delays to prevent false failure indications.

A Seal Failure condition will be indicated on Chan A if:

An open circuit exists for a **minimum of 15 seconds, 3 times in a 24-hour period**
OR

An open circuit exists for a **minimum of 45 seconds.**

If an alarm condition exists, the Chan A LED will illuminate ORANGE.
If/when the alarm condition clears, the Chan A LED will flash to indicate an alarm existed, but does not exist currently, until the Reset pushbutton is pressed.

A High Temperature condition will be indicated on Chan B if:

an open circuit exists for a **minimum of 2 seconds, 3 times in a 24-hour period**
OR

an open circuit exists for a **minimum of 7 seconds.**

If an alarm condition exists, the Chan B LED will illuminate RED.
If/when the alarm condition clears, the Chan B LED will flash to indicate an alarm existed, but does not exist currently, until the Reset pushbutton is pressed.

Once an alarm has occurred on either channel once in a 24-hour period, and cleared, any subsequent occurrence will not be restricted to the time delay. The circuit will indicate an alarm instantly upon recurrence of an alarm condition.