

Moyno®

20000

**SETTING THE
STANDARD**

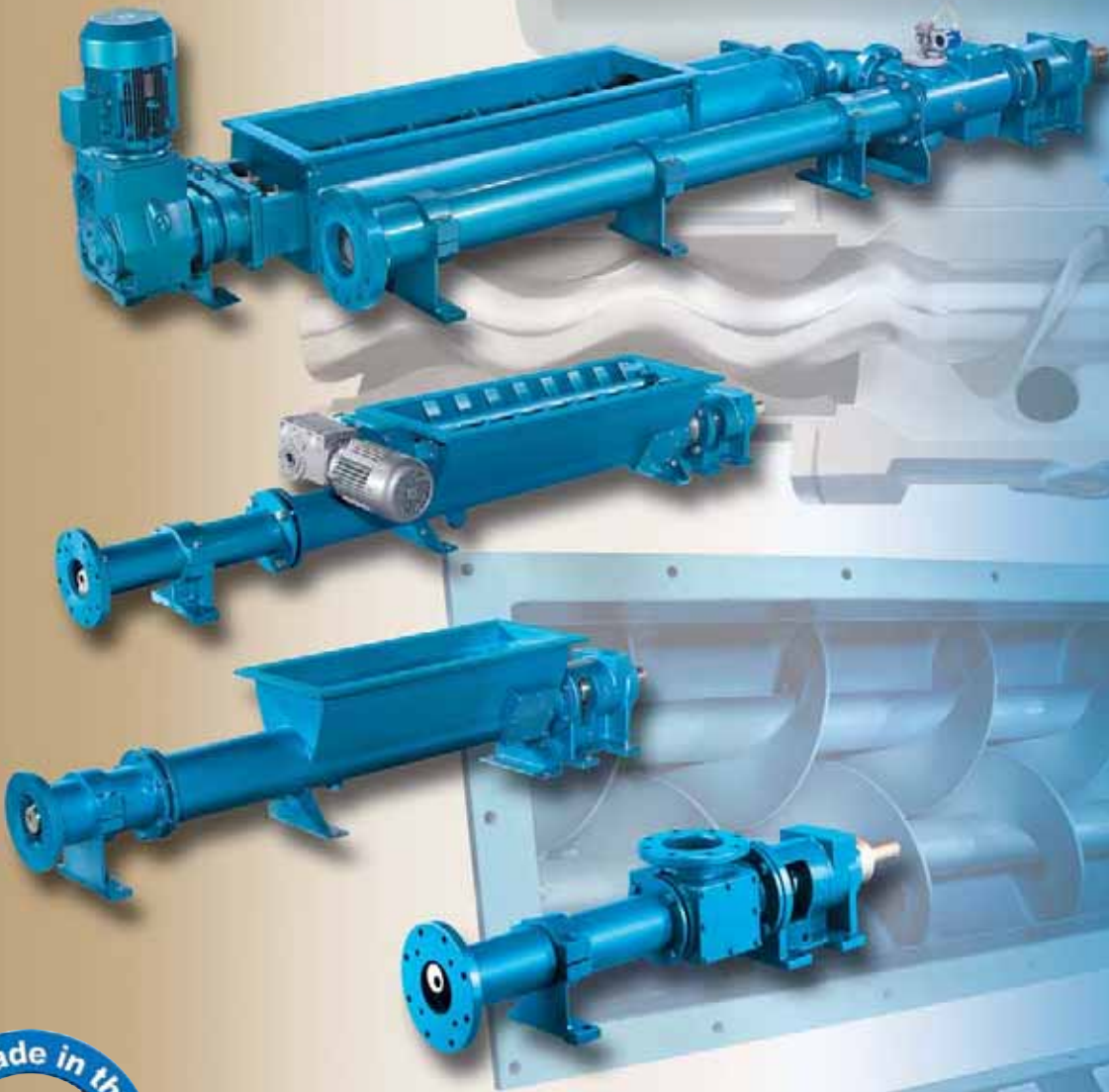

Always the Right Solution™

Moyno® 2000...Superior Pumping Performance

Moyno Sets the Standard

**Moyno Sets the Standard
in Durability**

**Moyno Sets the Standard
in Dependability**

**Moyno Sets the Standard
in Application Know-How**

**Moyno Sets the Standard
in Solving Pumping
Problems**

**Moyno Sets the Standard
in Technology**

**Moyno Sets the Standard
in Innovation**

**Moyno Sets the Standard
in Advanced Product Design**

**Moyno Sets the Standard
in Rotor Coatings**

**Moyno Sets the Standard
in Elastomer Technology**

**Moyno Sets the Standard
in Pumping Efficiency**

**Moyno Sets the Standard
in Product Quality**

**Moyno Sets the Standard
in State-of-the-Art Manufacturing**

**Moyno Sets the Standard
in Computer-Linked Field
Inventory**

**Moyno Sets the Standard
in Field Support**

**Moyno Sets the Standard
in Certified Service
Facilities**

**Moyno Sets the Standard
in PC Pump Specifications**

**Moyno Sets the Standard
in Total Customer
Satisfaction**

Moyno® 2000 pumps set the standard in positive displacement pumping applications. The proprietary Moyno 2000 gear-type universal joint design effectively handles radial and thrust loads for maximum performance and long life. These rugged pumps are able to handle abrasive materials in excess of 80% solids and offer a performance range to 4,500 GPM with pressure to 1,500 PSI.

By incorporating advanced technology, superior design and proprietary manufacturing processes, Moyno 2000 pumps offer the best value, and the most effective pumping solutions for the most extensive range of applications to satisfy all of your pumping needs.



Ultra-Technology Innovations

Moyno is able to deliver superior performance and greater overall customer value because of its proprietary Ultra-Technologies.

Ultra-Flex®

- Stator elastomers formulated for specific fluid conditions
- Over 40 stator elastomers available
- Highly researched formulations provide optimal blend of polymers and special ingredients
- Outstanding performance and long service life

Ultra-Pro®

- Optimized geometric profiles for rotor and stator
- High capacity, high efficiency, low internal velocities, minimal slip and low abrasive wear
- Available in 1:2 and 2:3 geometries for a broader application range

Ultra-Feed®

- Superior feed and flow efficiency
- Widest selection of auger feed technologies
- Available in open throat, bridge breaker and twin screw feeder configurations

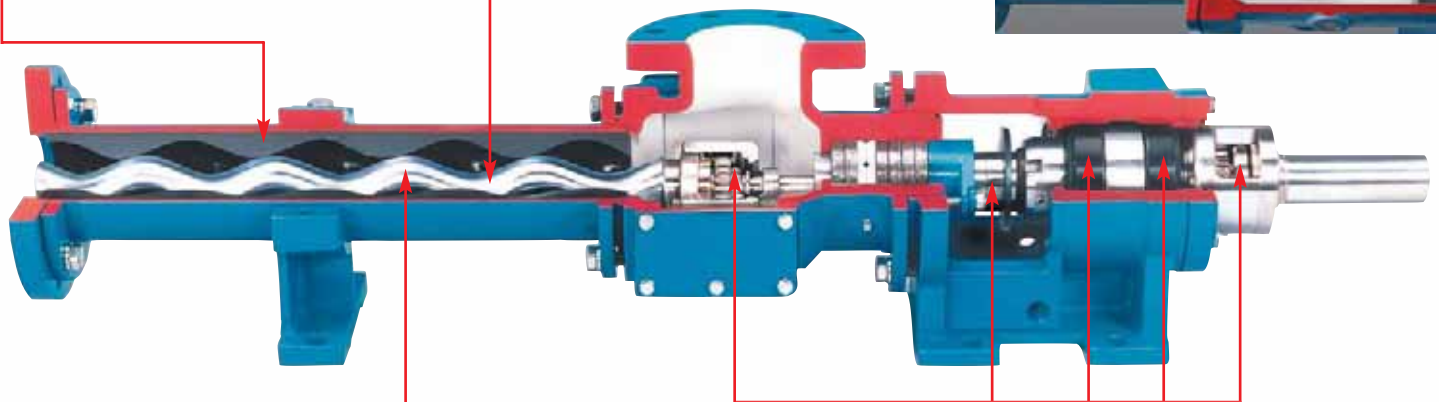
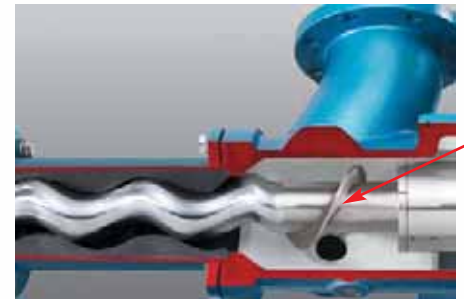

Ultra-Shield®

- Over 8 premium rotor coatings for peak performance
- Specially engineered materials matched to specific application requirements
- Excellent wear and corrosion resistance and longer life

Ultra-Drive®

- Proprietary Moyno gear joint effectively separates high thrust and radial forces
- Years of successful applications verify Moyno's gear joint design superiority
- Hollow shaft design provides the shortest progressing cavity pump footprint and extends bearing and seal life
- Tapered roller bearings positively locked in place with no snap rings or shimming required

Moyno 2000 G1 Pumps

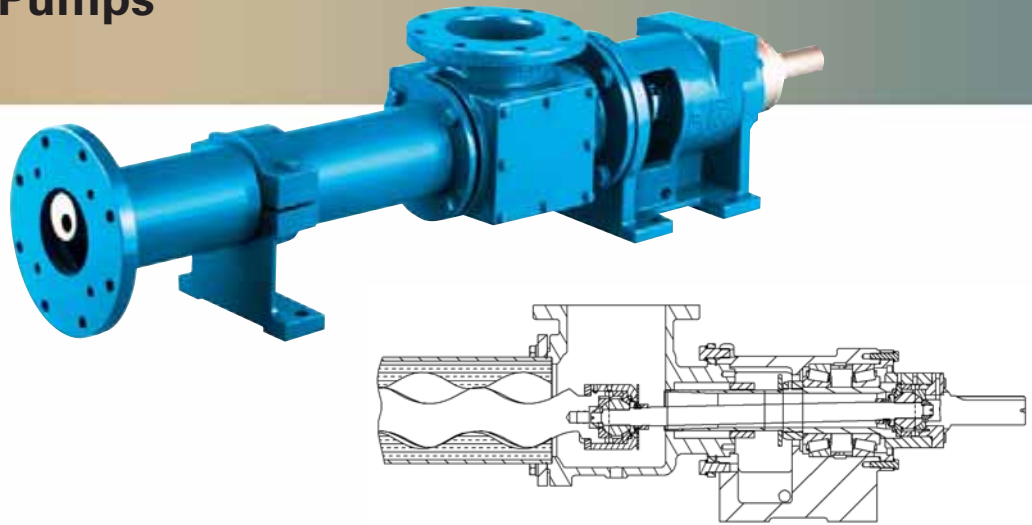

Flanged Design

Fluid Type:	Broad range of viscosities and solids
Fluid Supply:	Via standard pipe
Benefits:	Robust design with bearings integral to the pump
Typical Applications:	<ul style="list-style-type: none">• Oils• Polymers• Municipal sludge to 10% solids• Titanium Dioxide• Paper coatings• Mining slurries

Moyno 2000 CC Pumps

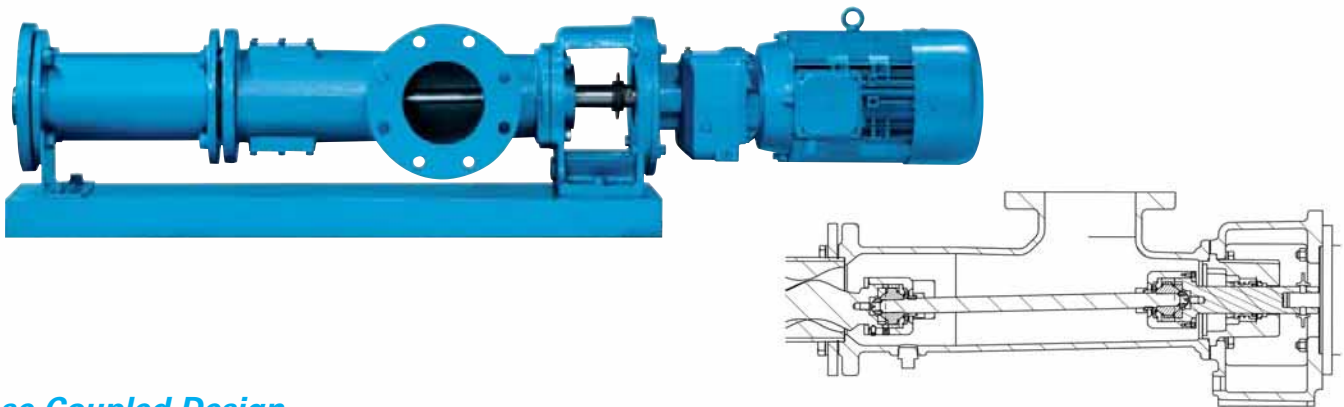

Close Coupled Design

Fluid Type:	Broad range of viscosities and solids
Fluid Supply:	Via standard pipe
Benefits:	Best value for majority of applications
Typical Applications:	<ul style="list-style-type: none">• Municipal sludge to 10% solids• Scum and grease• Dewatering equipment feeding• Lime slurry transfer and dosing• Polymer transfer and dosing• Chemical metering and transfer• Influent and effluent sampling

Moyno 2000 G2 Pumps

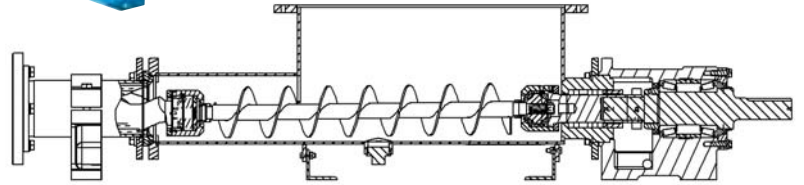

Single Auger Feed

Fluid Type:	Viscosity and solids where open inlet is required
Fluid Supply:	<ul style="list-style-type: none"> • Via wide open-throats and chutes • Capable of varying length to match wide feed areas from centrifuges and 1-, 1.5-, and 2-meter length belt filter presses
Benefits:	<ul style="list-style-type: none"> • Single auger feed mechanism to stuff product into the pump elements for increased fill efficiency • Wide open-throat minimizes plugging that could occur in a standard inlet
Typical Applications:	<ul style="list-style-type: none"> • Heavy clay slurries • Gypsum • Grout • Grape must • Municipal GBT sludge • Municipal sludge to 15% solids • Thick industrial sludges

Moyno 2000 G3 Pumps

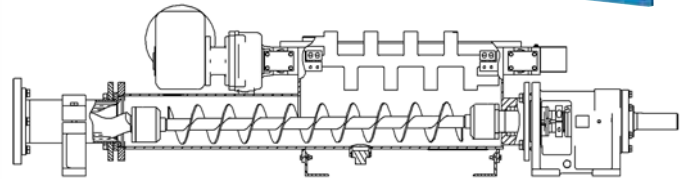
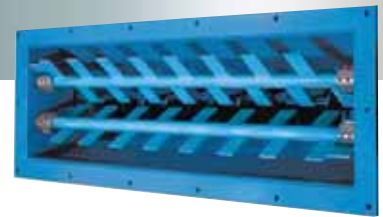

Single Auger Feed with Bridge Breaker

Fluid Type:	Medium- to high-viscosity and solids where product bridging is a concern
Fluid Supply:	<ul style="list-style-type: none"> • Via wide open-throats and chutes • Capable of varying length to match wide feed areas from centrifuges and 1-, 1.5-, and 2-meter length belt filter presses
Benefits:	<ul style="list-style-type: none"> • Independently driven Moyno bridge breaker has the flexibility to operate at different RPM from the pump • Single auger feed mechanism to stuff product into the pump elements for increased fill efficiency • Wide open-throat minimizes plugging that could occur in a standard inlet
Typical Applications:	<ul style="list-style-type: none"> • Pharmaceutical pastes • Heavy petroleum sludges • Plasticizers • Municipal sludge in excess of 30% solids • Paper stock in excess of 12% solids

Moyno 2000 HS Systems

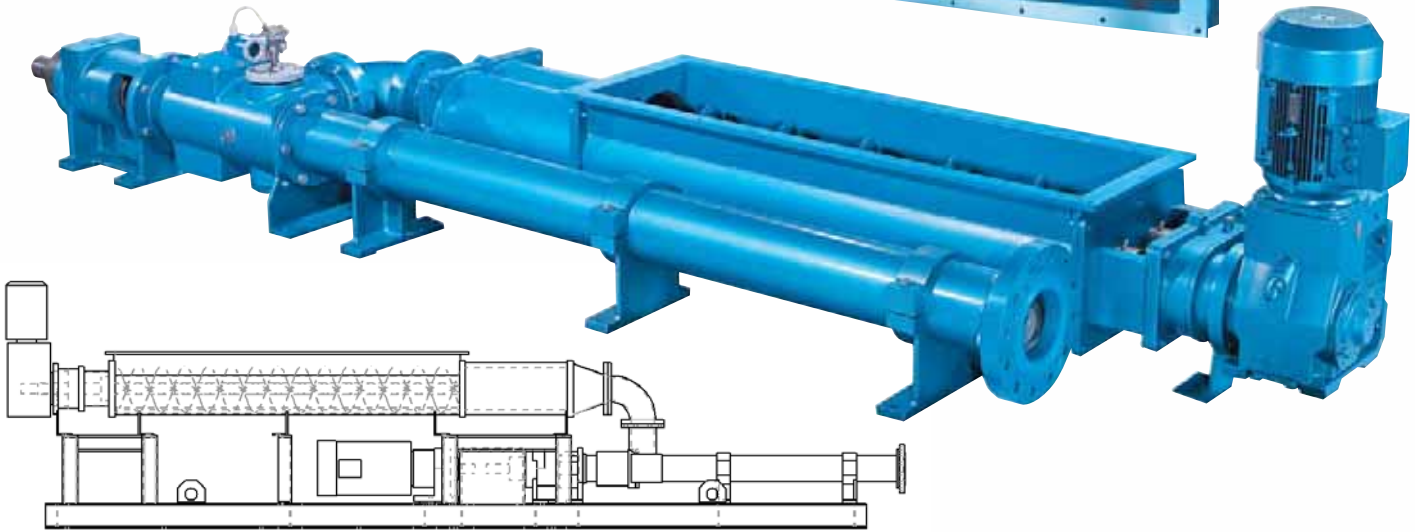
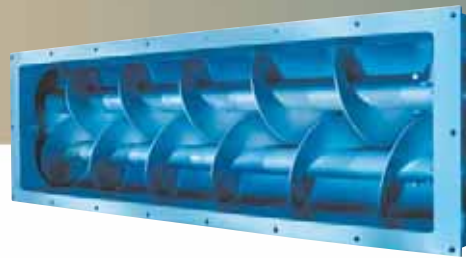

Dual Auger Feed and G4 Pump

Fluid Type:	High-viscosity and high-solids
Fluid Supply:	<ul style="list-style-type: none">• Via suction hopper of Twin Screw Feeder (TSF) and chutes• Capable of varying TSF length to match wide feed areas from centrifuges and 1- through 3-meter length belt filter presses
Benefits:	<p>Twin Screw Feeder</p> <ul style="list-style-type: none">• Capable of varying auger sizes without changing pump arrangement to match the width of the TSF opening to the drop zone• Concentric rotation in a close tolerance pressure tube allows the TSF to generate positive stuffing pressure to the pump inlet (normally between 10 to 30 PSI at the pump inlet)• Dual augers counter-rotate to create a pull-down effect with the product• Intermeshing augers provide self-cleaning action so product will not stick to the augers and fill in the flights• Sidewalls are completely vertical into the augers, which does not allow product to bridge• Close tolerance to sidewalls eliminates product ledge where bridging can gain a foothold• TSF can be run at separate RPM from the pump, allowing control over the amount of stuffing pressure <p>G4 Pump</p> <ul style="list-style-type: none">• Universal joint is out of flow path for unobstructed flow to pump cavity inlet• Wide sweep pump inlet to lower friction loss• Patented auger feed on rotor head stuffs product directly into the cavity without obstruction
Typical Applications:	<ul style="list-style-type: none">• Municipal sludge from 15% to over 50% solids• Non-flowable products• Calcium Carbonate• Magnesium Hydroxide paste• Cellulose fiber• Spent grain• Battery paste

Moyno 2000 G4 Pumps

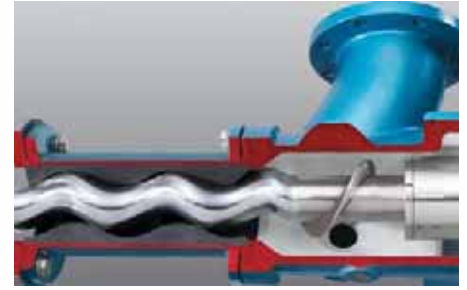
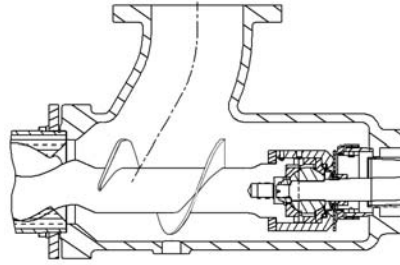
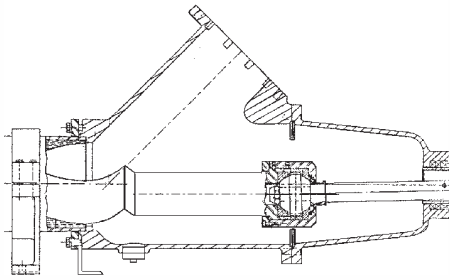

45° Inlet Design

Fluid Type:	Low- to medium-viscosity and large solids
Fluid Supply:	Via standard pipe
Benefits:	<ul style="list-style-type: none"> • Universal joint is out of flow path for unobstructed flow to pump cavity inlet • 45° inlet lowers friction loss and provides for more gentle handling of product • Patented auger feed on rotor head stuffs product directly into the cavity without obstruction
Typical Applications:	<ul style="list-style-type: none"> • Vacuum applications from deaerator and evaporators • Scum transfer • Thick adhesives • Municipal sludge in excess of 10% solids • Whole fish

Ultra-Serv[®] Service Programs

Your critical applications demand prompt, responsive service and support. Our network of experienced Moyno Certified Service Facilities offer you:

- Maintenance and cost reduction ideas, plus expert trouble shooting assistance
- Preventative maintenance programs and service contracts
- Extensive local inventory of genuine Moyno replacement parts
- Warrantied repairs
- 24-hour service and support

When purchasing genuine Moyno replacement parts and service from one of our Certified Service

Facilities, you can be confident you are receiving the highest quality service and parts available for your Moyno pump. The proprietary Moyno NetLink™ System electronically connects the inventories of all stocking distributors to enhance accessibility to the Moyno part you need and reduce process delays. Experts in Moyno products and pumping applications, Moyno Certified Service Facilities offer knowledgeable support and attentive service



to ensure you receive an effective, long-lasting pumping solution for each application.

Pump Accessories and Options

Moyno 2000 series pumps offer an extensive range of accessories and options designed to meet your exact application needs.

- Flush Gland – Allows packing leakage to be washed away from the pump



- Fiber Deflector – Prevents ragging around pump connecting rod and rotor head



- Shaft Sleeve – Protects drive shaft from wear in highly abrasive applications



- Control Packages – Various control packages are available, including the advanced, integrated touch screen packages found on the 2000 HS system as well as run-dry fluid detection

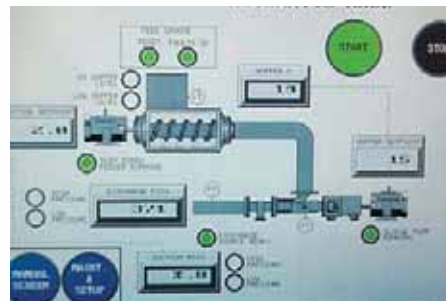

- Slip Ring Injection System – Reduces nominal line pressure when transferring extremely dry material over long distances

- Wide variety of drive options, couplings, mechanical seals, packing, motor controls, gauge packages and jacketing for handling materials that must be kept hot or chilled



For information about Moyno products or for technical assistance, contact:

Moyno, Inc.
P.O. Box 960
Springfield, OH 45501-0960
U.S.A.
Telephone: 1-877-4UMOYNO
Facsimile: 937-327-3572
E-Mail: info@moyno.com

www.moyno.com

Bulletin 120-F



Always the Right Solution™

Note: Information contained herein is subject to change without notice. Before making a final product selection, please contact your Moyno representative.

Your Moyno Authorized Distributor/Representative is: