

# Grundfos CUE

Variable frequency drives for pump control  
50/60 Hz



be  
think  
innovate

**GRUNDFOS** 

<b>1. Introduction</b>	<b>3</b>	<b>8. Operation</b>	<b>40</b>
Grundfos CUE	3	Control panel	40
Built-in E-pump functionality	3	Startup guide	40
Designed for Grundfos pumps	3	CUE settings document	40
Further technical documentation	3	Warning and alarm list	41
<b>2. Features and benefits</b>	<b>4</b>	<b>9. CUE selection</b>	<b>42</b>
User interface	4	How to select a CUE	42
Functions	4	Special conditions	43
Inputs and outputs	5	High ambient temperature	43
Standards	5	Selection tables	44
Accessories	5	<b>10. Technical data</b>	<b>50</b>
<b>3. Identification</b>	<b>6</b>	Main dimensions and weight	50
Nameplate	6	Surroundings	52
<b>4. Applications</b>	<b>7</b>	Sound pressure level	52
Overview	7	Torques for terminals	52
<b>5. Product range</b>	<b>8</b>	Cables	52
Overview	8	Inputs and outputs	53
<b>6. Functions</b>	<b>9</b>	Fuses	54
Overview	9	<b>11. Accessories</b>	<b>59</b>
Operating modes	11	Product numbers	59
Control modes	11	MCB 114 sensor input module	60
Setpoints	18	Connectors	61
Setting the direction of rotation	21	Grundfos Local Control Panel, GLCP	61
Status functions	21	Remote-mounting option for GLCP	61
Logging functions	21	Floor-mounting option	62
PID controller	22	IP21/NEMA1 option	63
Stop functions	23	Grundfos differential pressure sensor, DPI	68
Dry-running protection	24	Temperature sensor, TTA	69
Duty/standby	24	<b>12. Grundfos Product Center</b>	<b>71</b>
Operating range	25	Grundfos GO	72
Motor bearing monitoring	25		
Standstill heating	26		
Ramps	26		
Proportional differential pressure, parabolic	26		
Hmax update	27		
Differential pressure from two sensors	27		
Start delay after power-on	27		
Auto/manual restart after alarm	27		
Limit exceeded	28		
Copy of settings	28		
Pipe fill (PC Tool)	28		
Digital inputs	29		
Signal relays	30		
Analog inputs	31		
Analog output	31		
GENibus	31		
MCB 114 sensor input module	32		
<b>7. Installation</b>	<b>33</b>		
Mechanical installation	33		
Electrical installation	34		
RFI filters	37		
Output filters	37		
EMC-correct installation	39		

# 1. Introduction

## Grundfos CUE

The CUE is a series of variable frequency drives designed for speed control of a wide range of Grundfos pumps.



Fig. 1 Grundfos CUE solution

## Designed for Grundfos pumps

The CUE can be used in both new and existing installations, but the pump and motor should be suitable for use with variable frequency drives.

The table below shows the Grundfos pump types for which the CUE is designed.

Pump type	Pump type
AFG	Euro HYGIA
AMD	F&B HYGIA
AMG	HS
BM, BMB	LC, LF
BME, BMET, BMEX	MAXA, MAXANA
BMP	MTA, MTH, MTR
CH, CHI, CHN, CHV	MTB
CHIU	NB, NK
CM	NBG, NKG
CMV	RC
Contra	S
CPH, CPV	SE, SEN, SEV
CR, CRI, CRN, CRT	SP, SP-G, SP-NE
CRK	SPK
CV	SRP
DP, EF	TP
Durietta	VL

## Built-in E-pump functionality

The CUE solution contains the same control functionality as the Grundfos E-pumps and is thus a supplement to the E-pump range. See the table below.

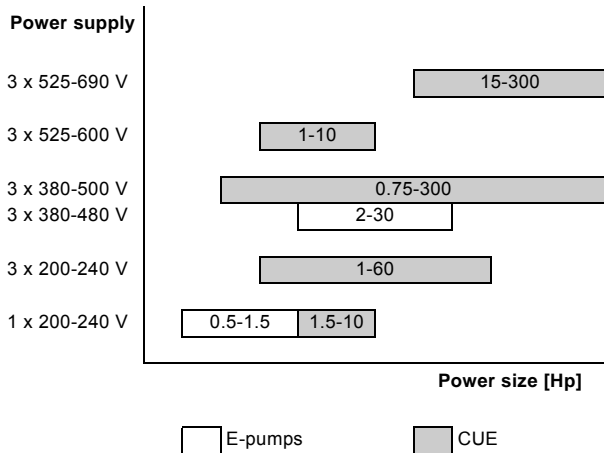

## Further technical documentation

- Installation and operating instructions, 0.75 - 125 Hp, contain all information for putting the CUE into operation.
- Installation and operating instructions, 150 - 300 Hp, contain all information for putting the CUE into operation.
- Installation and operating instructions of the MCB 114 sensor input module contain all information for installation of the MCB 114.

Technical documentation is available online via the Grundfos Product Center at [www.grundfos.us](http://www.grundfos.us).

If you have any questions, please contact the nearest Grundfos company or service workshop.

## 2. Features and benefits

### User interface

The user interface offers these possibilities:

- Local operation via a control panel with graphic display where the menu structure is based on the well-known system from Grundfos E-pumps.
- Remote operation via external signals, for instance via digital inputs or GENIbus.
- Monitoring of operating status via indicator lights and signal relays.
- Display of alarm or warning and logging of the last five alarms and warnings.

### Functions

#### Control modes for centrifugal pumps

The CUE has a wide range of pump-specific functions:

- Open loop:  
The speed is kept at a set value in the range of min. and max. speed.
- Proportional differential pressure:  
The differential pressure is reduced at a falling flow rate and increased at a rising flow rate.
- Constant differential pressure:  
The differential pressure is kept constant, independently of the flow rate.
- Constant pressure:  
The pressure is kept constant, independently of the flow rate.
- Constant level:  
The liquid level is kept constant, independently of the flow rate.
- Constant flow rate:  
The flow rate is kept constant, independently of the head.
- Constant temperature:  
The liquid temperature is kept constant, independently of the flow rate.
- Constant other value:  
Any other value is kept constant.

**Note:** If the pump speed exceeds the rated speed, the pump will be overloaded.

#### Startup guide

The CUE has a startup guide, which is started at the first startup. Here, a number of parameters are set automatically on the basis of the pump type. Other parameters are set manually on the basis of the data on the motor and pump nameplates. The startup guide can be repeated, if necessary.

Thanks to the startup guide, the installer can quickly set central parameters and put the CUE into operation.

#### Direction of rotation test

During the startup guide, the CUE automatically tests and sets the correct direction of rotation without changing the cable connections if a pressure/flow sensor is connected. The direction of rotation test is performed manually if no sensor is connected.

#### Duty/standby

The duty/standby function is used to alternate between two pumps. Each pump is connected to a CUE unit. The primary task is to start the standby pump if the duty pump is stopped due to an alarm and to alternate the two pumps at least every 24 hours.

Duty/standby operation increases the security of supply and ensures that the standby pump does not get stuck.

#### Dry-running protection

To protect the pump, select the dry-running function together with an external sensor so that lack of inlet pressure or water shortage can be detected.

#### Low-flow stop function

In constant pressure or constant level control mode, the stop function is used for changing between on/off operation at low flow rate and continuous operation at high flow rate.

The low-flow stop function protects the pump and saves energy.

#### Monitoring of lubrication of motor bearings

When the bearing monitoring function is active, a warning will appear in the display when the motor bearings are to be relubricated or replaced. Furthermore, the function provides an estimated time to service.

This improves motor maintenance.

## Inputs and outputs

The CUE is equipped with a number of inputs and outputs:

- 1 RS-485 GENIbus connection
- 1 analog input, 0-10 V, 0/4-20 mA
  - external setpoint
- 1 analog input, 0/4-20 mA
  - sensor input, feedback sensor
- 1 analog output, 0-20 mA
- 4 digital inputs
  - start/stop and 3 programmable inputs
- 2 signal relays (C/NO/NC)
  - programmable.

## Standards

The CUE is designed according to the following directives and standards:

- EMC Directive 2004/108/EC
- Low Voltage Directive 2006/95/EC
- EN 61800-5-1:2003/IEC 61800-5-1:2003
- EN 61800-3:2005/IEC 61800-3:2004/IEC 60034-11
- EN 6034-12/IEC 60034-12/IEC 60038/IEC 62114
- EN 50102
- EN ISO 2409
- EN ISO 3743-1
- EN ISO 4871
- EN ISO 11203
- DIN 44082.

## Accessories

Grundfos offers a number of accessories for the CUE.

### MCB 114 sensor input module

The MCB 114 is an option offering additional analog inputs for the CUE:

- 1 analog input, 0/4-20 mA
- 2 inputs for Pt100/Pt1000 temperature sensors.

### Output filters

Output filters are used primarily for protecting the motor against overvoltage and increased operating temperature. However, output filters can also be used for reduction of acoustic motor noise.

Grundfos provides two types of output filter as accessories for the CUE:

- dU/dt filters
- sine-wave filters.

### Floor mounting option

The CUE is installed on the wall by default. The enclosures D1h and D2h can also be installed on the floor on a pedestal designed for that purpose.

For information about enclosures, see page [50](#).

### IP21/NEMA1 option

An IP20 enclosure can be upgraded to IP21/NEMA1 by using the IP21/NEMA1 option. The power terminals (power supply and motor) will be covered.

## 3. Identification

### Nameplate

The CUE can be identified by means of the nameplate. An example is shown below.



Fig. 2 Example of nameplate

Text	Description
T/C	CUE (product name) 202P132... (internal code)
Prod. no	Product number: 96754460
S/N	Serial number: 123456G358 The first six digits are the serial number of the unit. The letter G is the code for production site. The last three digits indicate the production date: 35 is the week, and 8 is the year 2008.
0.75 kW	Typical shaft power on the motor
IN	Supply voltage, frequency and maximum input current
OUT	Motor voltage, frequency and maximum output current. The maximum output frequency usually depends on the pump type.
CHASSIS/IP20	Enclosure class
Tamb.	Maximum ambient temperature

## 4. Applications

### Overview

The CUE is a multi-purpose variable frequency drive suitable for a variety of applications demanding reliable and cost-efficient pump operation.

The CUE is used in five main fields of application:

#### Water supply and pressure boosting

Besides general water supply in municipal and industrial waterworks, the CUE is used for these specific applications:

- water supply
- pressure boosting
- washing.

The typical control modes are constant pressure, constant flow rate. Stop functions are used to stop the pump when the water flow is low.

#### Heating and air-conditioning

Liquid transfer:

- heating applications
- cooling and air-conditioning applications.

The typical control modes are proportional pressure or constant temperature.

#### Process and sanitary applications

Liquid transfer:

- breweries and dairies
- pure-water applications
- process applications
- purification applications.

The CUE is typically controlled by an external controller. The typical control mode is open loop.

#### Groundwater

Typical applications:

- groundwater supply to waterworks
- irrigation in horticulture and agriculture
- dewatering.

The typical control modes are constant pressure, constant flow rate or constant level control.

#### Wastewater

Transfer of water:

- wastewater
- effluent
- drainage water
- process water.

The typical control mode is constant level function (emptying function).

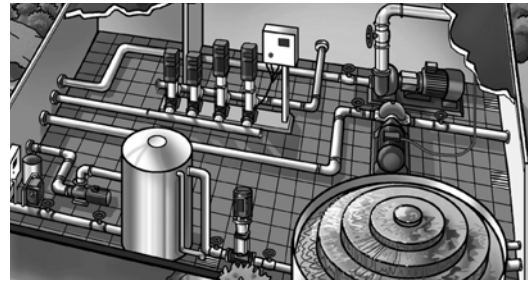

TM03 0146 4204

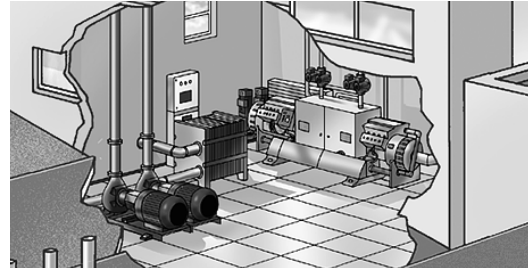

TM03 0147 4204



TM03 0148 4204

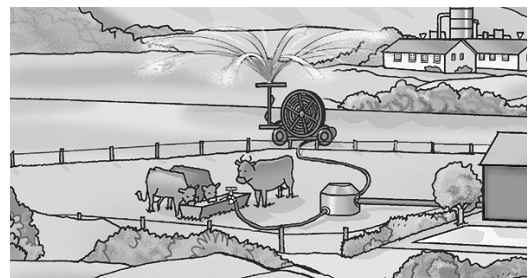

TM03 0149 4204

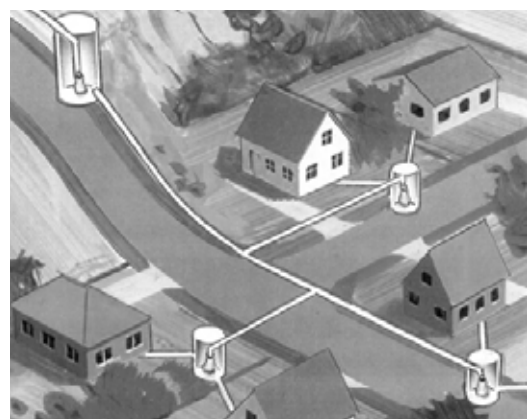

TM04 0223 5107

## 5. Product range

### Overview

The CUE cabinet sizes are characterized by their enclosures. The table shows the relation between power size (P2), power supply (V) and enclosure class (IP). It shows the complete range of the CUE.

Typical shaft power P2		Power supply and enclosure class													
		1 x 200-240 V			3 x 200-240 V		3 x 380-500 V				3 x 525-600 V		3 x 525-690 V		
[Hp]	[kW]	IP20	IP21	IP55	IP20	IP55	IP20	IP21	IP54	IP55	IP20	IP55	IP21	IP54	IP55
0.75	0.55						•			•					
1	0.75				•	•	•			•		•	•		
1.5	1.1	•		•	•	•	•			•	•	•			
2	1.5		•	•	•	•	•			•	•	•			
3	2.2		•	•	•	•	•			•	•	•			
4	3		•	•	•	•	•			•	•	•			
5	3.7		•	•	•	•									
5	4						•			•		•	•		
7.5	5.5		•	•	•	•	•			•	•	•			
10	7.5		•	•	•	•	•			•	•	•			
15	11				•	•	•			•			•		•
20	15				•	•	•			•			•		•
25	18.5				•	•	•			•			•		•
30	22				•	•	•			•			•		•
40	30				•	•	•			•			•		•
50	37				•	•	•			•			•		•
60	45				•	•	•			•			•		•
75	55						•			•			•		•
100	75						•			•			•		•
125	90						•			•			•		•
150	110							•	•				•	•	
200	132							•	•				•	•	
250	160							•	•				•	•	
300	200							•	•				•	•	
350	250							•	•				•	•	

For further information, see [Selection tables](#), page 44.



## 6. Functions

### Overview

The table below shows the functions offered by the CUE.

CUE functions	Setting or reading via		
	CUE	GENIbus	PC Tool*
<b>Operating modes, see page 11</b>			
Normal	•	○	□
Stop	•	○	□
Min.	•	○	□
Max.	•	○	□
<b>Control modes, see page 11</b>			
Open loop	•	○	□
Proportional differential pressure	•	○	□
Constant differential pressure	•	○	□
Constant pressure	•	○	□
Constant pressure with stop function	•	○	□
Constant level	•	○	□
Constant level with stop function	•	○	□
Constant flow rate	•	○	□
Constant temperature	•	○	□
Constant other value	•	○	□
<b>Setpoints, see page 18</b>			
Setpoint, CUE menu	•		
External setpoint	•	○	□
GENIbus setpoint		○	
Predefined setpoints from digital inputs			□
<b>Additional functions, see page 21</b>			
Setting the direction of rotation	•		□
Status information	•		□
Logging information	•		□
PID controller	•	○	□
Stop functions	•		□
Dry-running protection	•		□
Duty/standby	•		□
Operating range	•	○	□
Motor bearing monitoring	•	○	□
Standstill heating	•	○	□
Ramps	•		□
Proportional differential pressure, parabolic			□
Hmax update			□
Differential pressure from two sensors			□
Start delay after power-up			□
Auto/manual restart after alarm		○	□
Limit exceeded		○	□
Copy of settings	•		
Pipe fill		○	□

• Default

○ Optional with GENIbus

□ Optional with PC Tool

\* PC Tool is a software program for connection of your computer to the CUE.

CUE functions	Setting or reading via		
	CUE	GENIbus	PC Tool*
<b>Digital inputs, see page 29</b>			
Start/stop	•		<input type="checkbox"/>
Min. (min. curve)	•		<input type="checkbox"/>
Max. (max. curve)	•		<input type="checkbox"/>
External fault	•		<input type="checkbox"/>
Flow switch	•		<input type="checkbox"/>
Alarm reset	•		<input type="checkbox"/>
Dry running (from external sensor)	•		<input type="checkbox"/>
Accumulated flow (from pulse flow sensor)	•		<input type="checkbox"/>
Additional set of ramps, ramp selector			<input type="checkbox"/>
Predefined setpoints from digital input			<input type="checkbox"/>
<b>Signal relays, see page 30</b>			
Ready	•		<input type="checkbox"/>
Warning	•		<input type="checkbox"/>
Alarm	•		<input type="checkbox"/>
Operation	•		<input type="checkbox"/>
Pump running	•		<input type="checkbox"/>
Relubricate	•		<input type="checkbox"/>
External relay control			<input type="checkbox"/>
Limit exceeded			<input type="checkbox"/>
<b>Analog inputs, see page 31</b>			
External setpoint	•		<input type="checkbox"/>
Sensor 1	•		<input type="checkbox"/>
<b>Analog output, see page 31</b>			
Feedback value			<input type="checkbox"/>
Speed			<input type="checkbox"/>
Frequency			<input type="checkbox"/>
Motor current			<input type="checkbox"/>
External setpoint input			<input type="checkbox"/>
Limit exceeded			<input type="checkbox"/>
<b>MCB 114 sensor input module, see page 60</b>			
Sensor input 2	•		<input type="checkbox"/>
Temperature sensor 1	•		<input type="checkbox"/>
Temperature sensor 2	•		<input type="checkbox"/>

- Default
- Optional with GENIbus
- Optional with PC Tool

\* PC Tool is a software program for connection of your computer to the CUE.

## Operating modes

These operating modes can be selected with the CUE:

- Normal
- Stop
- Min.
- Max.

The operating modes can be set without changing the setpoint setting.

### Normal

The pump operates in the control mode selected.

The control modes are different ways of controlling the pump speed when the operating mode is set to "Normal".

### Stop

The pump has been stopped by user.

### Min. curve

The pump is running at a set minimum speed value.

See fig. 3.

For instance, this operating mode can be used during periods with a very small flow requirement.

### Max. curve

The pump is running at a set maximum speed value.

See fig. 3.

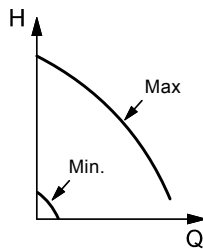

Fig. 3 Min. and max. curves

TM03 8813 2507

## Control modes

The CUE has a built-in PID controller that provides closed-loop control of the value you want to control. The CUE can also be set to open-loop control where the setpoint represents the desired pump speed.

Open loop is typically used without sensor. All other control modes require a sensor.

The tables on the following pages give an overview of the menu and show the functions and possible settings offered by the CUE.

## Menu overview

### Menu structure

The CUE has a startup guide, which is started at the first startup. After the startup guide, the CUE has a menu structure divided into four main menus:

1. "GENERAL" gives access to the startup guide for general setting of the CUE.
2. "OPERATION" enables the setting of setpoint, selection of operating mode and resetting of alarms. It is also possible to see the latest five warnings and alarms.
3. "STATUS" shows the status of the CUE and the pump. It is not possible to change or set values.
4. "INSTALLATION" gives access to all parameters. Here a detailed setting of the CUE can be made.

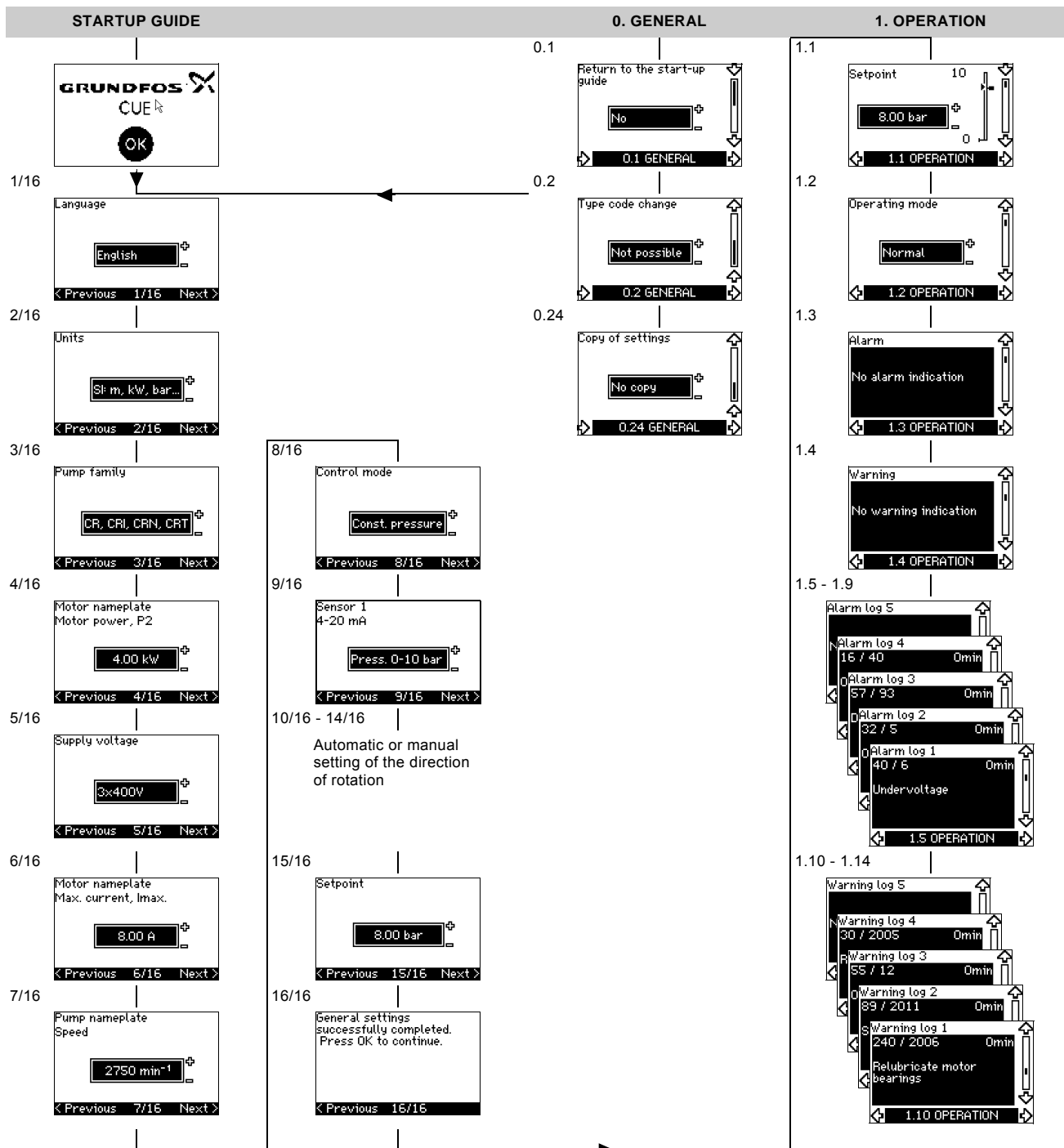
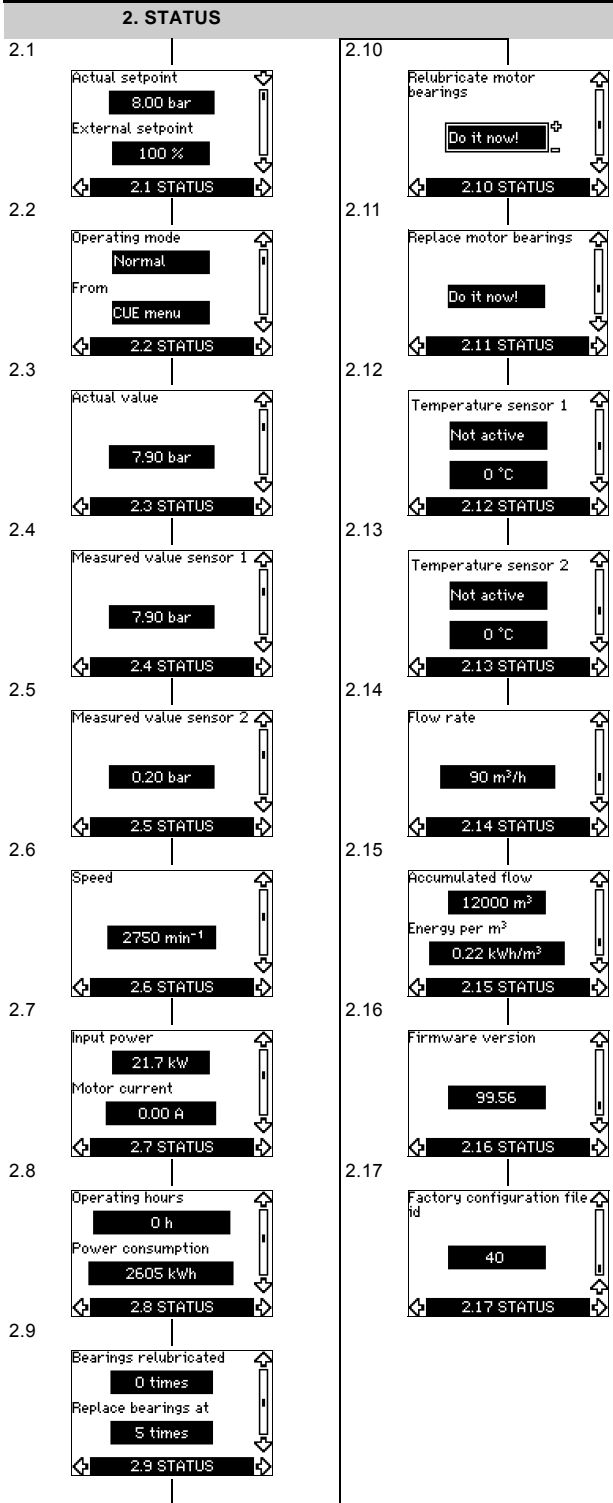
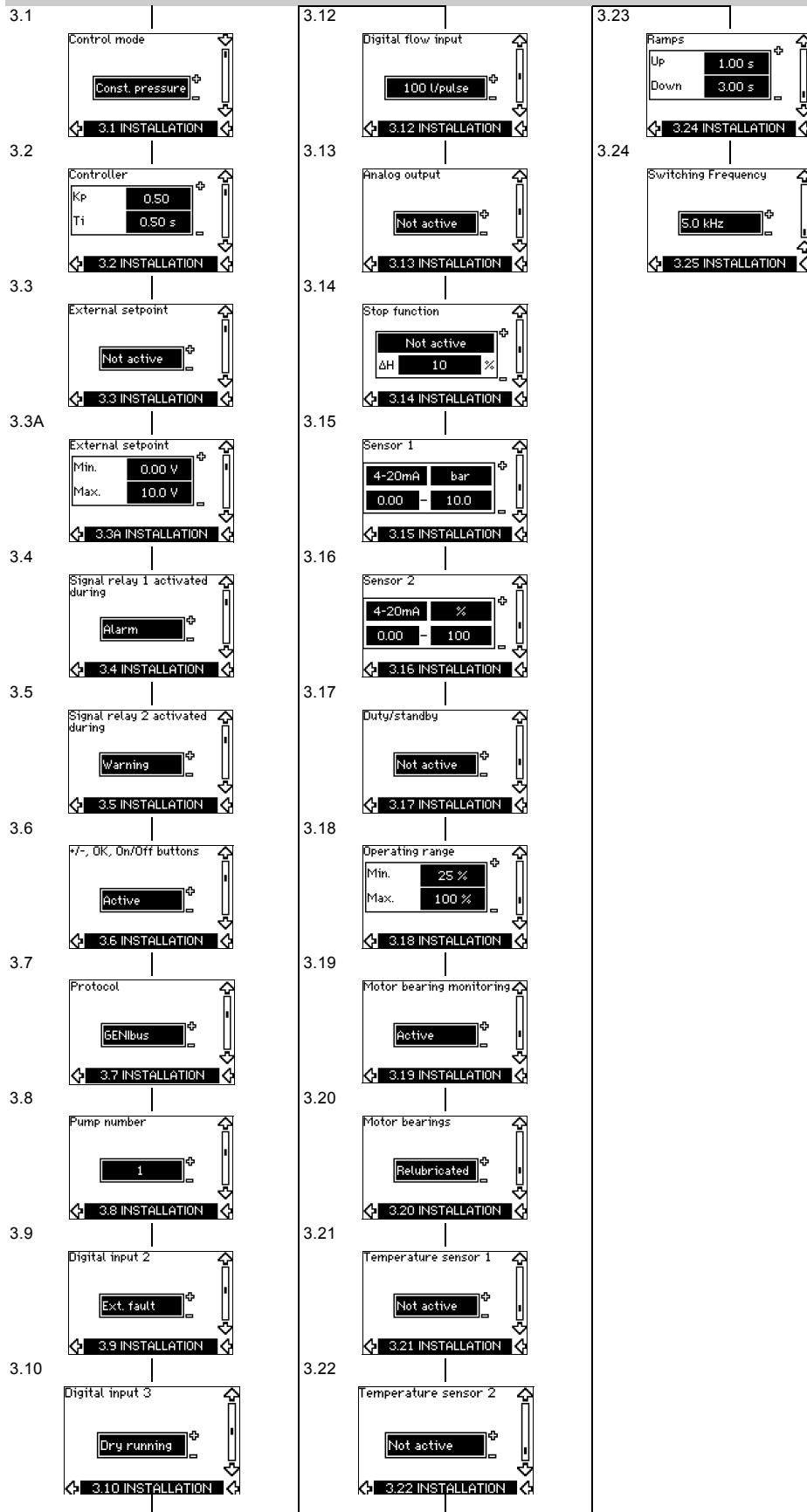

Fig. 4 Menu overview



## 3. INSTALLATION



## Overview

Pump type	Open loop	Proportional differential pressure	Constant differential pressure	Constant pressure	Constant level	Constant flow rate	Constant temperature	Constant other value
AFG	•				•	•		•
AMD	•				•	•		•
AMG	•				•	•		•
BM, BMB	•			•	•	•		•
BME, BMET, BMEX	•			•	•	•		•
BMP	•	•	•	•		•		•
CH, CHI, CHN, CHV	•			•	•	•	•	•
CHIU	•			•	•	•	•	•
CM		•	•	•	•	•	•	•
CMV								
Contra	•			•	•	•	•	•
CPH, CPV	•			•	•	•	•	•
CR, CRI, CRN, CRT	•			•	•	•	•	•
CRK	•			•	•	•	•	•
CV	•			•	•	•	•	•
DP, EF	•			•	•	•		•
Durietta	•			•	•	•	•	•
Euro HYGIA	•			•	•	•	•	•
F&B HYGIA	•			•	•	•	•	•
HS	•		•	•		•	•	•
LC, LF	•		•	•		•	•	•
MAXA, MAXANA	•		•	•	•	•	•	•
MTA, MTH, MTR	•			•	•	•	•	•
MTB	•			•	•	•	•	•
NB, NK	•		•	•	•	•	•	•
NBG, NKG	•		•	•	•	•	•	•
RC	•	•	•	•	•	•	•	•
S	•			•	•	•		•
SE, SEN, SEV	•			•	•	•		•
SP,SP-G, SP-NE	•			•	•	•	•	•
SPK	•			•	•	•	•	•
SRP	•			•	•	•		•
TP	•	•	•	•	•	•	•	•
VL	•			•	•	•	•	•
Other	•	•	•	•	•	•	•	•

See further description on the next pages.

### Open loop, constant curve

The speed is kept at a set value in the range between the min. and max. curves. See fig. 5.

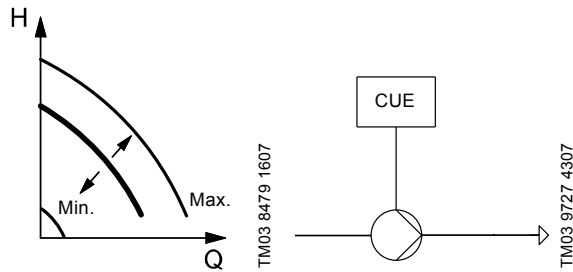

Fig. 5 Open loop, constant curve

In "Open loop" control mode, the setpoint is set in % of the nominal speed. The setting range will be between the min. and max. curves.

Operation on constant curve can for instance be used for pumps with no sensor connected.

This control mode is also typically used in connection with an overall control system such as Control MPC or another external controller.

### Proportional differential pressure

The differential pressure of the pump is reduced at falling flow rate and increased at rising flow rate. See fig. 6.

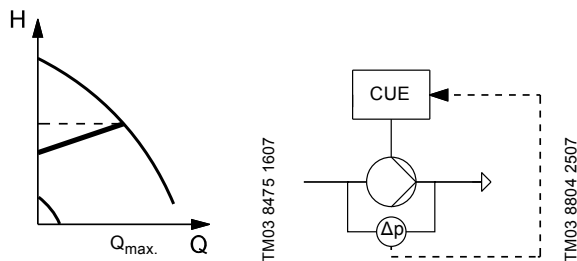

Fig. 6 Proportional differential pressure

The pump is controlled according to a differential pressure measured across the pump. This means that the pump system offers a proportional differential pressure in the Q-range of 0 to  $Q_{max.}$ , represented by the sloping line in the QH diagram.

### Constant differential pressure, pump

The differential pressure of the pump is kept constant, independently of the flow rate. See fig. 7.

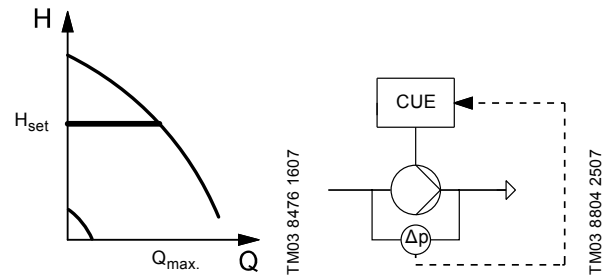

Fig. 7 Constant differential pressure, pump

The pump is controlled according to a constant differential pressure measured across the pump. This means that the pump system offers constant differential pressure in the Q-range of 0 to  $Q_{max.}$ , represented by the horizontal line in the QH diagram.

### Constant differential pressure, system

The differential pressure of the system is kept constant, independently of the flow rate. See fig. 8.

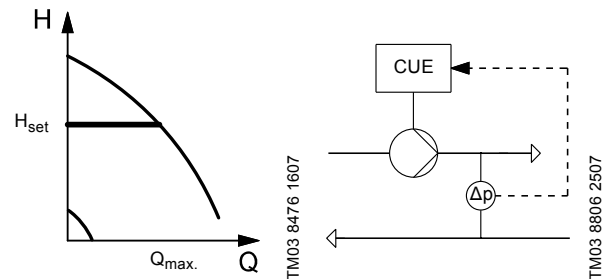

Fig. 8 Constant differential pressure, system

The pump is controlled according to a constant differential pressure measured across the system. This means that the pump offers constant differential pressure of the system in the Q-range of 0 to  $Q_{max.}$ , represented by the horizontal line in the QH diagram.



### Constant pressure

The outlet pressure is kept constant, independently of the flow rate. See fig. 9.

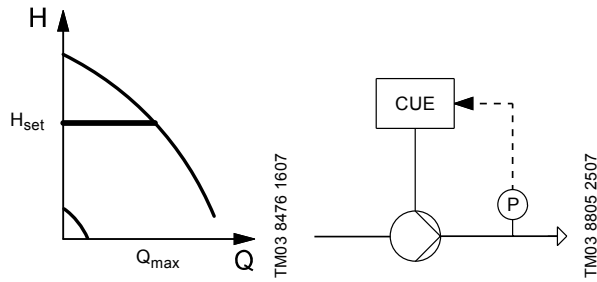

Fig. 9 Constant pressure

The pump is controlled according to a constant pressure measured after the pump. This means that the pump offers a constant pressure in the Q-range of 0 to  $Q_{max}$ , represented by the horizontal line in the QH diagram.

### Constant pressure with stop function

The outlet pressure is kept constant at high flow rate ( $Q > Q_{min}$ ). On/off operation at low flow rate. See fig. 10.

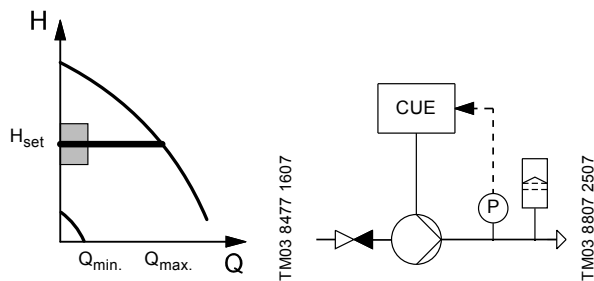

Fig. 10 Constant pressure with stop function

The pump is controlled according to a constant pressure measured after the pump. This means that the pump offers a constant pressure in the Q-range of  $Q_{min}$  to  $Q_{max}$ , represented by the horizontal line in the QH diagram.

### Constant level

The liquid level is kept constant, independently of the flow rate. See fig. 11.

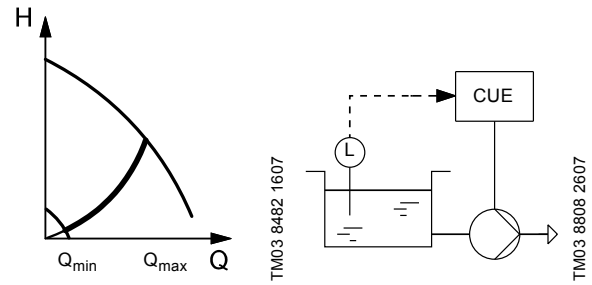

Fig. 11 Constant level

The pump is controlled according to a constant liquid level. This means that the pump offers a constant level in the Q-range of  $Q_{min}$  to  $Q_{max}$ , represented by the parable line in the QH diagram.

The function is an emptying function by default.

### Constant level with stop function

The liquid level is kept constant at high flow rate. On/off operation at low flow rate. See fig. 12.

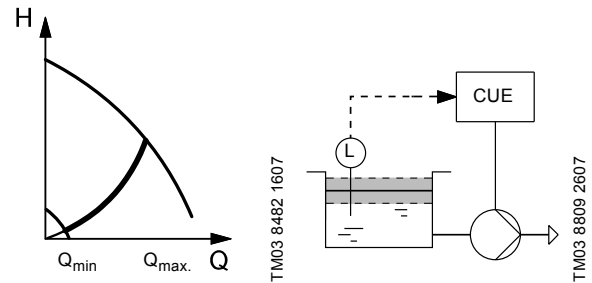

Fig. 12 Constant level with stop function

The pump is controlled according to a constant liquid level. This means that the pump offers a constant level in the Q-range of  $Q_{min}$  to  $Q_{max}$ , represented by the parable line in the QH diagram.

The function is an emptying function by default.

## Constant flow rate

The flow rate is kept constant, independently of the head. See fig. 13.

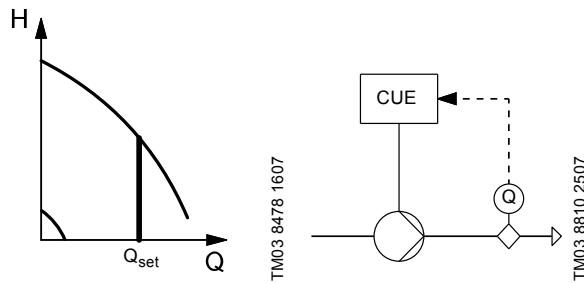

Fig. 13 Constant flow rate

The pump is controlled according to a constant flow rate, represented by the vertical line in the QH diagram.

## Constant temperature

The liquid temperature is kept constant, independently of the flow rate. See fig. 14.

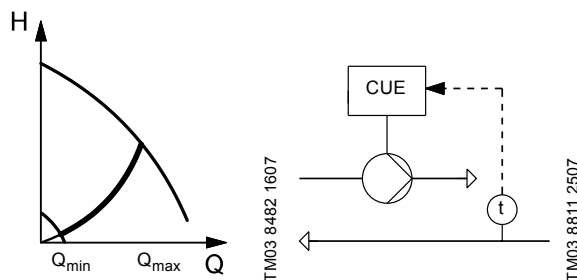

Fig. 14 Constant temperature

The pump is controlled according to a constant temperature. This means that the pump offers a variable flow rate in the Q-range of  $Q_{min}$  to  $Q_{max}$ , represented by the parable line in the QH diagram.

## Constant other value

Any other value is kept constant. See the CUE installation and operation instructions for further information.

## Setpoints

The setpoint is normally set in the "OPERATION" menu via the CUE control panel. If needed, the setpoint can be influenced via the external setpoint input.

The CUE offers these setpoint possibilities:

- Setpoint, CUE menu (default)
- External setpoint (default)
- Predefined setpoints (setting via PC Tool)
- GENibus setpoint (setting via GENibus).

## Setpoint, CUE menu

The setpoint can default be set by the user via the CUE control panel when the CUE is in local operating mode and no digital inputs are used for predefined setpoints.

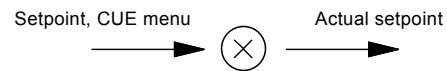

Fig. 15 Setpoint, CUE menu

The setpoint range depends on the selected control mode.

In "Open loop" control mode, the setpoint is set in % corresponding to the required speed. The setting range is between the min. and max. curves in % of nominal frequency.

In "Proportional differential pressure" control mode, the setting range is equal to 25 % to 90 % of max. head.

In all other control modes, the setting range is equal to the sensor measuring range.

### Setting the setpoint by means of the OPERATION menu

The setpoint can be set or changed during operation using the setpoint display in the "OPERATION" menu shown below. It is not necessary to run the start guide to change the setpoint.

### External setpoint

The setpoint set via the CUE menu can be influenced by connecting an analog signal to the external setpoint input.

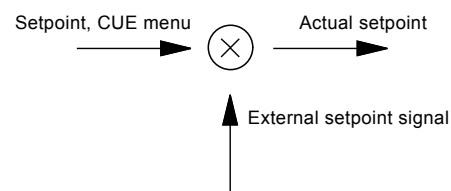

Fig. 16 Setpoint, CUE menu and external setpoint signal

This function offers these possibilities:

- External setpoint (default)
- Inverse external setpoint (setting via control panel)
- External setpoint with stop (setting via PC Tool)
- External setpoint based on a reference table (setting via PC Tool).

The external setpoint signal is used for calculating the actual setpoint. The minimum signal is the minimum setpoint, and the maximum signal is the setpoint set via the CUE menu. See fig. 17.

**External setpoint influence (default)**

The actual setpoint is a linear function of the external setpoint signal. See fig. 17.

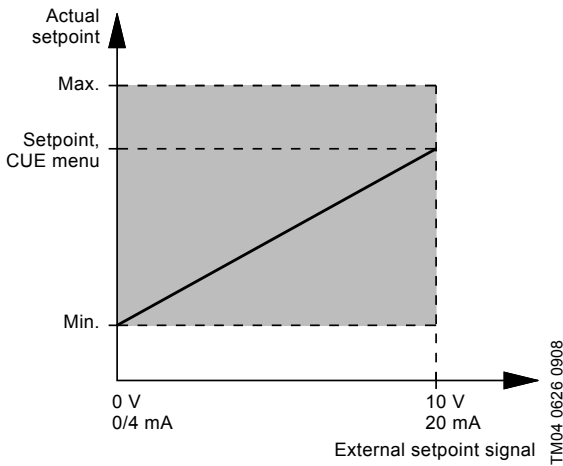

**Fig. 17** External setpoint

The minimum and maximum values of the external setpoint signal can be set via PC Tool. See fig. 18.

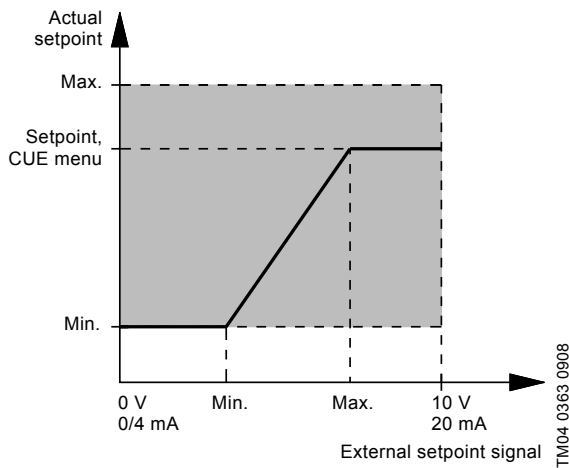

**Fig. 18** Reduced external setpoint signal

**Inverse external setpoint**

The actual setpoint is an inverse linear function of the external setpoint signal. See fig. 19.

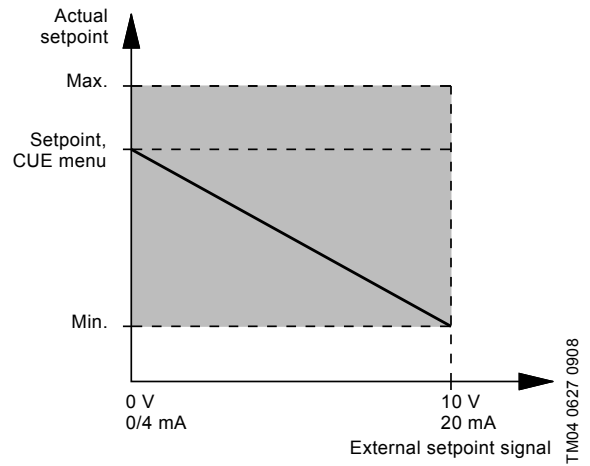

**Fig. 19** Inverse external setpoint signal

The minimum and maximum values of the external setpoint signal can be set via the control panel. See fig. 20.

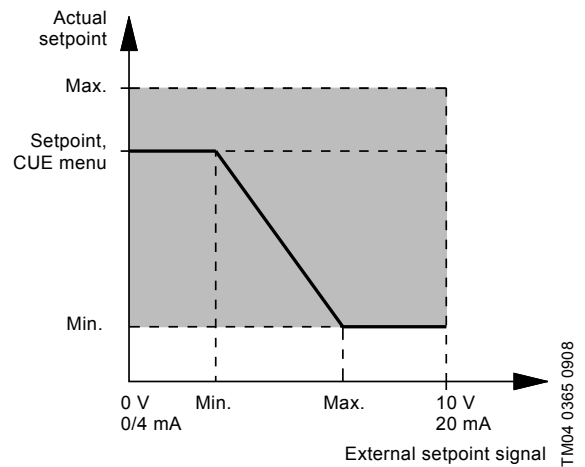

**Fig. 20** Reduced inverse external setpoint signal

### External setpoint with stop function

Setting via PC Tool.

The actual setpoint with stop is a linear function of the external setpoint signal above 20 % signal and on/off operation below 20 % signal. See fig. 21.

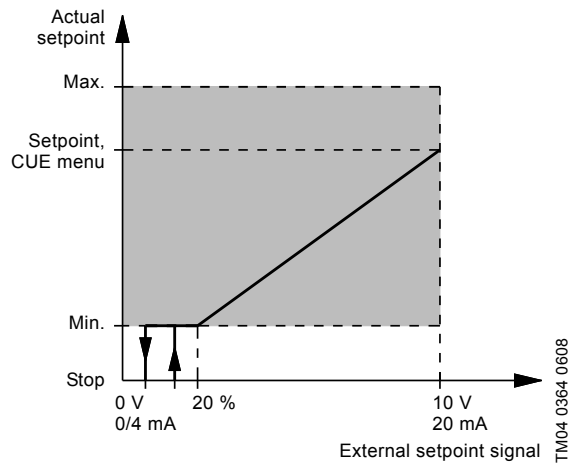

Fig. 21 External setpoint with stop function

When the external setpoint signal is below 10 %, the operating mode is "Stop".

When the external setpoint signal is above 15 %, the operating mode is "Normal".

### External setpoint based on a reference table

Setting via PC Tool.

The actual setpoint is a piecewise linear function of the external setpoint signal. See fig. 22.

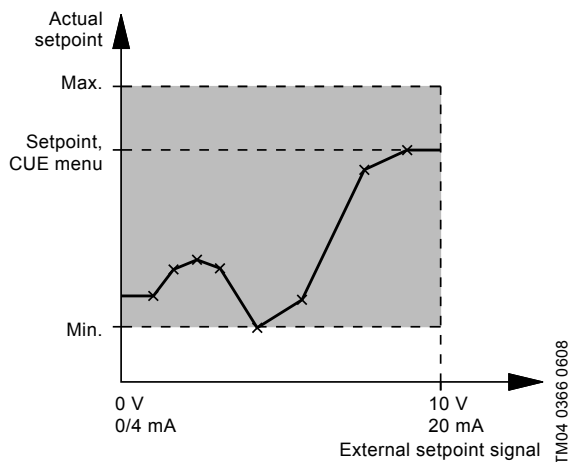

Fig. 22 External setpoint based on a reference table

The linear function is defined as an interpolation between the points in a table. The table has up to eight points.

### Predefined setpoints

Setting via PC Tool.

This function makes it possible to select up to seven predefined setpoints using one to three digital inputs.

The setpoints are selected as a binary coding of the digital inputs as shown in the table below.

Predefined setpoint	DI 2	DI 3	DI 4
1	x		
2		x	
3	x	x	
4			x
5	x		x
6		x	x
7	x	x	x

x = Closed contact

If none of the digital inputs are activated, the operating mode can be configured to "Stop" or to being controlled according to a setpoint set via the control panel.

If "Min.", "Max." or "Stop" is selected via the control panel, the predefined setpoints are overruled.

**Note:** Predefined setpoints cannot be influenced by the external setpoint input.

### GENibus setpoint

If the CUE is remote-controlled via the GENibus input, the setpoint is set via the bus.

**Note:** The GENibus setpoint cannot be influenced by the external setpoint signal.

## Setting the direction of rotation

The startup guide is started the first time the CUE is connected to supply voltage. Then while going through the startup guide, the CUE tests and sets the correct direction of rotation without changing the cable connections to the motor.

The correct direction of rotation can be set in these ways:

- automatic setting.
- manual setting when the direction of rotation is visible.
- manual setting when the direction of rotation is not visible.

### Automatic setting

The CUE automatically tests and sets the correct direction of rotation without changing the cable connections.

Automatic setting requires a sensor. The sensor can be a pressure or a flow sensor.

This test is not suitable for all pump types and will in certain cases not be able to determine for certainty the correct direction of rotation. In these cases, the CUE changes over to manual setting where the direction of rotation is determined on the basis of the installer's observations.

### Manual setting when the direction of rotation is visible

The correct direction of rotation is set manually without changing the cable connections. This requires that it is possible to observe the motor fan or shaft.

### Manual setting when the direction of rotation is not visible

The correct direction of rotation is set manually without changing the cable connections. This requires that it is possible to observe the head or flow rate.

## Status functions

The CUE shows these data:

- power consumption
- operating hours
- accumulated flow
- energy per m<sup>3</sup> (requires flow meter).

The status information can be shown in the display.

### Power consumption

The value of the power consumption is an accumulated value calculated from the pump's birth and cannot be reset. No additional sensor is required.

### Operating hours

The value of operating hours is an accumulated value calculated from the pump's birth and cannot be reset. No additional sensor is required.

### Accumulated flow

The value of accumulated flow is calculated by means of a flow measurement from either a digital pulse input or an analog input.

When using a digital input, the number of pulses is counted and multiplied by the liter/pulse parameter in order to get the accumulated flow.

When using an analog input, the accumulated flow value is updated every 10 seconds with the volume pumped in that period.

### Energy per m<sup>3</sup>

The actual energy per m<sup>3</sup> (kWh/m<sup>3</sup>) is calculated as actual power consumption divided by actual flow rate.

## Logging functions

### Alarm and warning log

The latest five alarms and five warnings are logged with a timestamp corresponding to the power-on time after the fault has occurred. The alarm and warning log can be shown directly on the display.

See section [Warning and alarm list](#), page 41.

### Correlated histogram (setting via PC Tool)

The correlated histogram is a way to examine the joint distribution of two parameters. The logging for a correlated histogram is a count of the number of samples that, at the same time, are within a given interval of variable 1 and variable 2.

## PID controller

The CUE has a built-in PID controller for speed control of pumps. The factory setting of gain ( $K_p$ ) and integral time ( $T_i$ ) can easily be changed in the control panel.

The controller can operate in both normal and inverse mode.

### Normal mode

Normal mode is used in systems in which an increase in pump performance will result in a rise in the value measured at the feedback sensor. This will typically be the case in most CUE applications.

Normal mode is selected by setting the gain ( $K_p$ ) to a positive value in the control panel.

### Inverse mode

Inverse mode is used in systems in which an increase in pump performance will result in a drop in the value measured at the feedback sensor. This mode will typically be used for constant level operation (emptying tank) and for constant temperature operation in cooling systems.

Inverse mode is selected by setting the gain ( $K_p$ ) to a negative value in the control panel.

### Description

The PID controller compares the required setpoint ( $p_{set}$ ) with the actual value ( $p$ ) measured by the transmitter (P). See fig. 23.

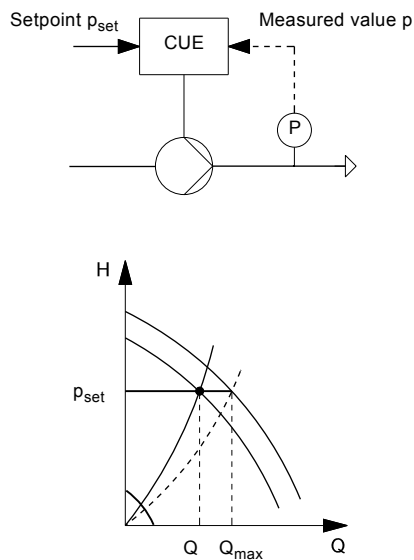

Fig. 23 Constant pressure control

If the measured value is higher than the required setpoint, the PID controller will reduce the speed and the performance of the pump until the measured value is equal to the required setpoint.

## Suggested controller settings

System/application	$K_p$		$T_i$
	Heating system <sup>1)</sup>	Cooling system <sup>2)</sup>	
	0.2		0.5
	0.5		0.5
	0.2		0.5
	-2.5		100
	0.5	-0.5	$10 + 5L_2$
	0.5		$10 + 5L_2$
	0.5	-0.5	$30 + 5L_2^*$
	0.5		$0.5^*$
	0.5		$L_1 < 16.4 \text{ ft (5 m): } 0.5^*$ $L_1 > 16.4 \text{ ft (5 m): } 3^*$ $L_1 > 32.8 \text{ ft (10 m): } 5^*$

\*  $T_i = 100$  seconds (factory setting).

Heating systems are systems in which an increase in pump performance will result in a rise in temperature at the sensor.  
Cooling systems are systems in which an increase in pump performance will result in a drop in temperature at the sensor.

$L_1$  = Distance in [ft (m)] between pump and sensor.

$L_2$  = Distance in [ft (m)] between heat exchanger and sensor.

TM04 0367 0608

## Stop functions

### Constant pressure with stop function

The purpose of the stop function is to stop the pump when low or no flow is detected.

When low flow is detected, the pump is in on/off operation. If there is flow, the pump will continue operating according to the setpoint. See fig. 24.

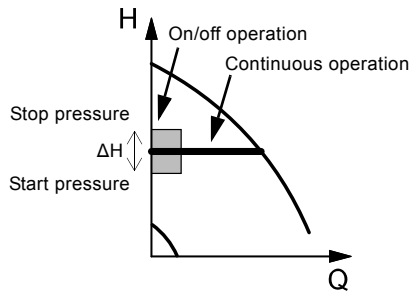

TM03 8477 1607

**Fig. 24** Constant pressure with stop function. Difference between start and stop pressures ( $\Delta H$ )

Low flow can be detected in two different ways:

- with the built-in low-flow detection function
- with a flow switch connected to a digital input.

#### Low-flow detection function

The low-flow detection function will check the flow regularly by reducing the speed for a short time. No or only a small change in pressure means that there is low flow.

#### Low-flow detection with flow switch

When a flow switch detects low flow, the digital input will be activated.

#### Operating conditions for the stop function

It is only possible to use the stop function if the system incorporates these components:

- a pressure sensor
- a check valve
- a diaphragm tank.

**Note:** The check valve must always be installed before the pressure sensor. See figures 25 and 26.

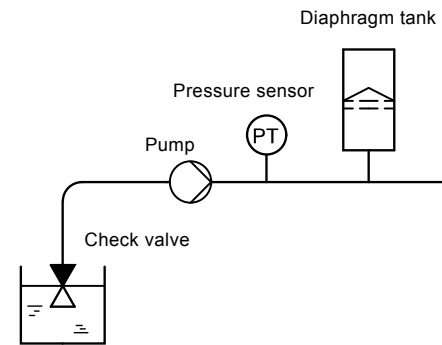

TM03 8562 1907

**Fig. 25** Position of the check valve and pressure sensor in a system with suction lift operation

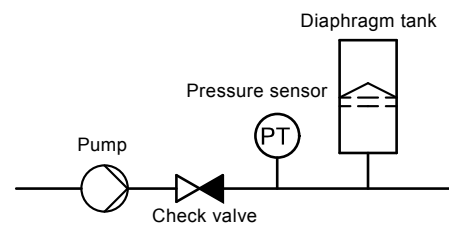

TM03 8563 1907

**Fig. 26** Position of the check valve and pressure sensor in a system with positive inlet pressure

#### Diaphragm tank

The stop function requires a diaphragm tank of a certain minimum size. The tank must be installed as close as possible after the pump, and the precharge pressure must be 0.7 x actual setpoint.

Recommended diaphragm tank size:

Rated flow rate of pump	Typical diaphragm tank size
[gal/min (m <sup>3</sup> /h)]	[gal (liter)]
0 - 26.4 (0 - 6)	2 (8)
30.8 - 105.7 (7 - 24)	5 (18)
110.0 - 176.1 (25 - 40)	13 (50)
180.5 - 308.2 (41 - 70)	32 (120)
312.6 - 440.3 (71 - 100)	48 (180)

If a diaphragm tank of the above size is installed in the system, the factory setting of  $\Delta H$  is the correct setting. If the tank installed is too small, the pump will start and stop too often.

## Constant level with stop function

The purpose of the stop function is to stop the pump when low or no flow is detected. When low flow is detected, the pump is in on/off operation. If there is flow, the pump will continue operating according to the setpoint. See fig. 27.

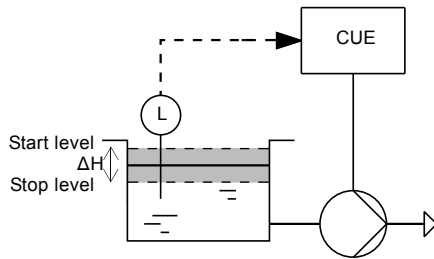

**Fig. 27** Constant level with stop function. Difference between start and stop levels ( $\Delta H$ )

Low flow can be detected in two different ways:

- with the built-in low-flow detection function
- with a flow switch connected to a digital input.

### Low-flow detection function

The low-flow detection function will check the flow regularly by measurement of speed and power.

### Low-flow detection with flow switch

When a flow switch detects low flow, the digital input will be activated.

**Note:** It is only possible to set constant level with stop function if the system incorporates a level sensor, and all valves can be closed.

## Dry-running protection

This function protects the pump against dry running. When lack of inlet pressure or water shortage is detected, the pump will be stopped before being damaged.

Lack of inlet pressure or water shortage can be detected in two ways:

- With a switch connected to a digital input configured to dry-running protection.
- The CUE checks if the shaft power is below a dry-pump limit for a configurable time (setting via PC Tool).

The use of a digital input requires an accessory, such as these:

- a Grundfos Liqtec® dry-running switch
- a pressure switch installed on the suction side of the pump
- a float switch installed on the suction side of the pump.

The pump cannot restart as long as the input is activated. Restart may be delayed by up to 30 minutes, depending on the pump family.

TM03 8809 2607

## Duty/standby

The built-in duty/standby function applies to two pumps connected in parallel to ensure reliability of supply. See fig. 28.

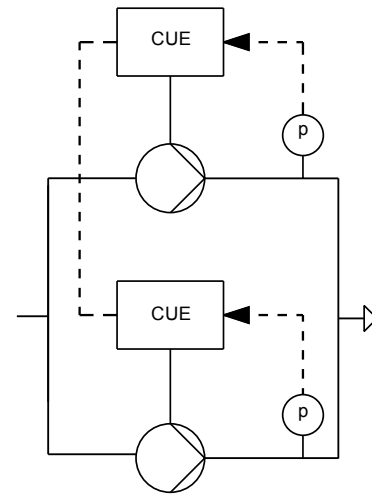

**Fig. 28** Two pumps connected in parallel and controlled via GENIbus

TM04 0368 0608

These are the primary purposes of the function:

- To let one pump run at the time.
- To start the standby pump if the duty pump stops due to an alarm.
- To alternate the pumps at least every 24 hours.

### Description

The two pumps are electrically connected by means of the GENIbus interface. Each pump must be connected to its own CUE and sensor.

**Note:** The two pumps running duty/standby in this way cannot use the GENIbus interface for remote communication.

The function is activated via the control panel.

### Operating mode

The two pumps use their own local operating mode. For instance, Pump 1 can operate in "Normal" mode, and Pump 2 can operate in "Max." mode.

### Control mode

Both pumps must have the same control mode.5



## Operating range

How to set the operating range:

- Set the min. speed within the range from a pump-dependent min. speed to the adjusted max. speed. The factory setting depends on the pump family.
- Set the max. speed within the range from adjusted min. speed to the pump-dependent maximum speed. The factory setting will be equal to 100 %, i.e. the speed stated on the pump nameplate.

The area between the min. and max. speed is the actual operating range of the pump.

The operating range can be changed by the user within the pump-dependent speed range.

For some pump families, oversynchronous operation (max. speed above 100 %) will be possible. This requires an oversize motor to deliver the shaft power required by the pump during oversynchronous operation.

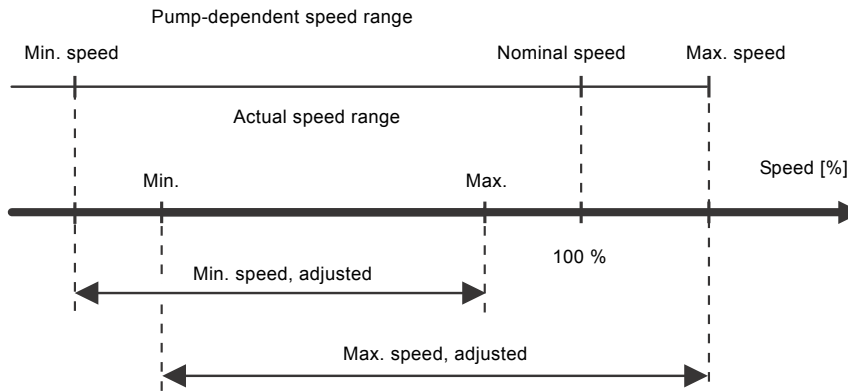

Fig. 29 Setting of the min. and max. curves in % of maximum performance

TM04 3581 4608

## Motor bearing monitoring

This function is used to give an indication when it is time to relubricate or change the motor bearings.

It shows this information:

- When to relubricate the motor bearings.
- How many times relubrication has been confirmed.
- When to replace the motor bearings.

### Default function

The default function is based on the "mileage" of the pump and takes into account if the pump has been running at reduced speed.

### Extended function

The bearing temperature is also included in the calculation.

The extended function requires an MCB 114 sensor input module and Pt100/Pt1000 sensors measuring the bearing temperature.

### Monitoring of motor bearing temperatures

When temperature sensors 1 and 2 are used for measuring the motor bearing temperature, a warning or an alarm will be generated if the bearing temperature gets too high.

Warnings and alarms are generated and reset using hysteresis. See fig. 30.

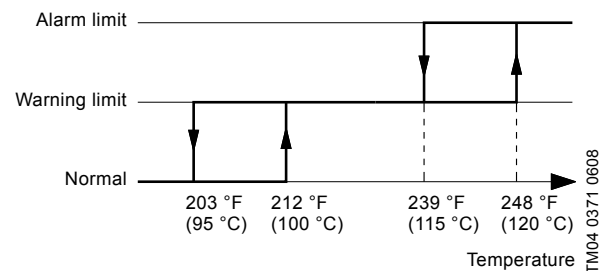

Fig. 30 Monitoring of bearing temperature with warning and alarm limits

TM04 0371 0608

## Standstill heating

This function preheats the motor during standstill in order to avoid condensation within the motor.

When the pump is stopped by a stop command, a current will be applied to the motor windings in order to keep the temperature within the motor above the dewpoint temperature. No external heater is needed.

The preheating of the motor is especially important when the motor is installed under these conditions:

- high humidity
- outdoor installation.

The consequences of condensed moisture within the motor are for example corrosion damage to electrical contacts and the bearings of the motor shaft.

## Ramps

The controller incorporates two types of ramp:

- ramp-up and ramp-down (default)
- initial and final ramps (setting via PC Tool).

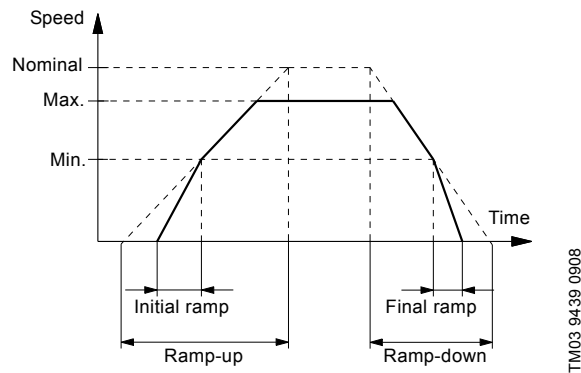

Fig. 31 Ramp-up and ramp-down of the CUE

### Ramp-up and ramp-down

The ramp-up and ramp-down are used for protection against overload when starting and stopping the CUE. The setting is done by means of the control panel.

The ramp-up time is the acceleration time from  $0 \text{ min}^{-1}$  to nominal motor speed.

The ramp-down time is the deceleration time from nominal motor speed to  $0 \text{ min}^{-1}$ .

### Additional set of ramp-up and ramp-down (setting via PC Tool)

An additional set of ramp-up and ramp-down can be remotely set to predefined ramps by means of a digital input.

### Initial and final ramps

The initial and final ramps prevent operation for a longer time than necessary at speeds below minimum speed.

The setting is done automatically based on the pump family selected in the startup guide.

## Proportional differential pressure, parabolic

Setting via PC Tool.

The proportional differential pressure can be selected with one of these flow dependencies:

- linear (default), see page 16
- parabolic (setting via PC Tool).

When the flow dependency is selected as parabolic, the differential pressure of the pump will be reduced with a parabolic curve at falling flow rate and increased at rising flow rate. See fig. 32.

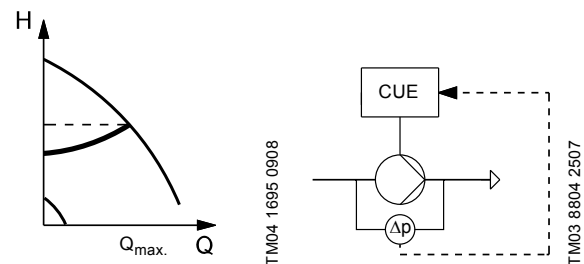

Fig. 32 Proportional differential pressure, parabolic curve

The pump is controlled according to a differential pressure measured across the pump. This means that the pump system offers a flow-compensated differential pressure in the Q-range of 0 to  $Q_{\text{max}}$ , represented by the parabolic curve in the QH diagram.

## $H_{max}$ update

Setting via PC Tool.

This function is used in connection with the control mode Proportional differential pressure. The purpose is to find the "true" value of the maximum head at no flow and nominal pump speed. See fig. 33.

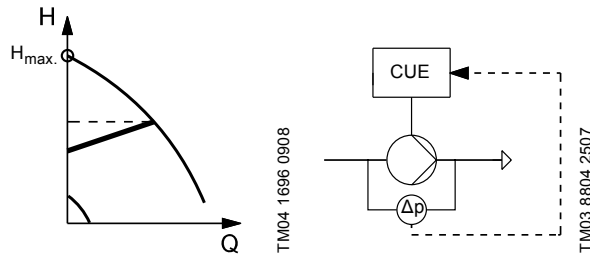

Fig. 33 Proportional differential pressure,  $H_{max}$  update

The function consists of two steps:

1. Ramping up the speed to nominal speed.
2. Measuring  $H_{max}$  for 20 seconds at nominal speed.

Valves must be closed so that the pump is operating without flow.

## Differential pressure from two sensors

Setting via PC Tool.

The purpose of this function is to make differential pressure control possible by using measurements from two separate pressure sensors.

It can be used in these control modes:

- Proportional differential pressure. See page 16
- Constant differential pressure. See page 16.

The function requires an MCB 114 sensor input module.

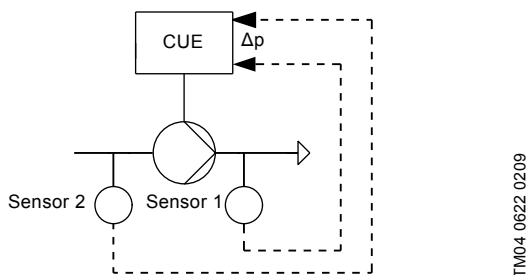

Fig. 34 Differential pressure from two sensors

Sensor 1 is connected to sensor input 1.

Sensor 2 is connected to sensor input 2 of an MCB 114 sensor input module.

## Start delay after power-on

Setting via PC Tool.

The start delay after power-on is a delay between power being applied and the pump starting.

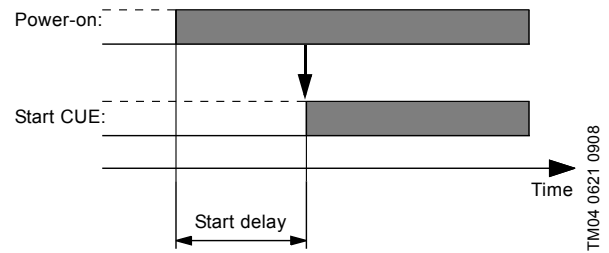

Fig. 35 Start delay after power-on

The purpose is to allow remote-control equipment to start up before the pump.

The start delay is deactivated if a remote command is received via GENIbus.

## Auto/manual restart after alarm

Setting via PC Tool.

In case of an alarm, the CUE will stop the pump or change the operating mode, depending on the alarm and pump type. See section [Warning and alarm list](#), page 41.

Pump operation will be resumed when the cause of the alarm has been remedied and the alarm has been reset automatically or manually.

The CUE can be configured to activate and deactivate automatic restart for all alarms or for groups of alarms.

## Limit exceeded

Setting via PC Tool.

This is a monitoring function offering information, warning or alarm when a low or high limit is exceeded. See fig. 36.

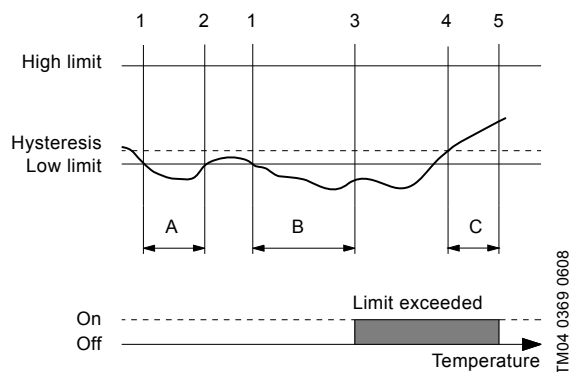

Fig. 36 Example of low limit exceeded

### Description

The function has two timers: a detection delay timer and a reset delay timer.

The detection delay timer starts when a limit is exceeded (1). See fig. 36. The time is configurable.

A: If the limit is no longer exceeded (2) when the detection time expires, the timer will be reset.

B: If the limit is still exceeded (3) when the detection time expires, the output of the detector will change to "limit exceeded".

The reset delay timer will start when the detector output is "limit exceeded" and the limit is no longer exceeded, using hysteresis (4).

C: When the delay time has expired (5), the detector output will change to "limit not exceeded".

### Input possibilities

It is possible to have two limit exceeded functions in parallel with these inputs:

- all analog inputs
- all Pt100/Pt1000 inputs.

The use of Pt100/Pt1000 inputs requires an MCB 114 sensor input module.

### Output possibilities

There are these output possibilities:

- signal relay 1 and 2
- analog output
- warning and alarm.

**Note:** The default setting of this function is "Not active".

## Copy of settings

It is possible to copy the settings of a CUE to another CUE of the same size and firmware version.

There are two possibilities:

- To copy the settings of a CUE to the control panel.
- To copy the settings stored in the control panel to a CUE.

Both functions must be used in the correct order to copy settings from one CUE to another. A setup can be used more than once when it has been copied into the Grundfos Local Control Panel.

## Pipe fill (PC Tool)

This function is used for filling empty pipes with water in a controlled manner. If the function is not activated, pipes will be filled at maximum speed. In pressure-controlled systems where pipes are empty at startup, high speed will cause water hammer until the speed has been reduced to fit the actual demand.

Water hammer can be prevented by introducing a pipe fill sequence before the system is running normal operation.

The pipe fill function can limit the speed of the pump when filling pipes, and thus reduce water hammer in filled pipes. A time limit or a pressure can be set to deactivate the pipe fill function and turn the CUE into normal operation.

### Parameters

#### Pipe fill

- Activation or deactivation of the function.

#### Pipe fill speed

- Maximum speed used during pipe fill (horizontal pipework).

#### Pipe fill time

- The time it takes to fill the pipes. The CUE will change to normal operation when the time has expired.

#### Pipe fill rate

- If a vertical pipe system is to be filled, a pipe fill rate can be set. Example: [0.3 bar/sec] (vertical pipework). The setting depends on the transmitter used.

#### Filled setpoint

- Setpoint where the pipe fill function is deactivated, and the CUE changes to normal operation.

## Digital inputs

As standard, the CUE offers these digital inputs:

- one digital input for external start/stop
- three programmable digital inputs.

The three digital inputs can be set to these functions:

- min. (min. curve)
- max. (max. curve)
- external fault
- flow switch
- alarm reset
- dry-running protection (via external switch)
- accumulated flow (pulse flow, only DI 4)
- predefined ramps (setting via PC Tool)
- predefined setpoints (setting via PC Tool).

### Start/stop

The pump will start if the pump is ready to run (the state of the on/off button is on, and no alarms prevent the pump from running).

#### Min.

The pump will run according to the min. curve.

#### Max.

The pump will run according to the max. curve.

#### External fault

If the input is activated for more than 5 seconds, external fault will be indicated.

#### Flow switch

The flow switch indicates no flow in constant pressure with stop function and constant level with stop function. It requires an external signal from a flow switch or a controller.

#### Alarm reset

When the input has been activated, the alarm will be reset if the cause of the alarm no longer exists.

#### Dry running

Indicates lack of inlet pressure or water shortage, and the pump will be stopped. The pump cannot restart as long as the input is activated. Restart may be delayed by up to 30 minutes, depending on the pump family. See page [57](#).

For further information, see page [24](#).

#### Accumulated flow (only DI 4)

The number of pulses is counted and multiplied by the liter/pulse parameter in order to get the accumulated flow. This requires the use of an accessory, such as a pulse sensor.

### Predefined ramps (setting via PC Tool)

The ramp-up and ramp-down time can be remotely set from the default setting to a predefined setting by means of PC Tool. An additional set of ramps can be selected via a digital input. The alternative ramps are set via PC Tool.

For further information, see page [26](#).

### Predefined setpoints (setting via PC Tool)

One to seven predefined setpoints can be selected via digital inputs configured for this purpose.

For further information, see section [Predefined setpoints](#), page [20](#).

## Signal relays

The two relay outputs can be independently set to these indications:

- ready
- alarm
- operation
- pump running
- warning
- relubricate
- external control (setting via PC Tool)
- limit exceeded (setting via PC Tool).

### Ready

The pump is ready to run or running.

### Warning

There is a warning.

### Alarm

There is an alarm.

### Operation

The pump is running or has been stopped by a stop function.

### Pump running

The pump is running.

### Relubricate



Lubrication time is exceeded.

### External relay control (setting via PC Tool)

This function offers information, warning or alarm when a signal is given via GENIbus.

### Limit exceeded (setting via PC Tool)

This function offers information, warning or alarm when a low or high limit is exceeded.

Function			Delay possible
Alarm	There is an unacknowledged alarm.	There is no alarm.	Yes
Warning	There is a warning, or the pump runs at reduced speed with respect to the reference.	The pump runs at requested speed and there is no warning.	No
Running	The pump is running.	The pump is not running.	No
Ready	The pump is ready to run or running, i.e. there is no alarm preventing the pump from running, e.g. a sensor alarm.	There is an alarm preventing the pump from running.	Yes
Operation	The system is on, i.e. the pump is running or stopped by the constant level stop function or constant pressure stop function.	The system is off, i.e. the pump is not running and is not stopped by one of the stop functions.	No
External control	Relay closed is requested by the fieldbus.	Relay open is requested by the fieldbus.	No
Limit exceeded (same action is required for both Limit exceeded 1 and 2)	Limit is exceeded.	Limit is not exceeded.	No
Lubrication time	Lubrication time is exceeded.	Lubrication time is not exceeded.	No

## Analog inputs

As standard, the CUE offers these analog inputs:

- one analog input for external setpoint
- one analog input for sensor 1.

### External setpoint

The setpoint can be influenced by connecting an analog signal to the setpoint input.

For further information, see page 18.

### Sensor 1

Sensor 1 is used for control in closed loop by default. In open loop, sensor 1 can be used for monitoring.

In closed loop, the feedback signal is kept at a given setpoint by a PID controller.

Switches A53 and A54 must be set according to signal type. See page 35.

## Analog output

The analog output (0-20 mA) can be set via PC Tool to one of these indications:

- feedback value
- speed
- frequency
- motor current
- external setpoint input
- limit exceeded.

The analog output is set to not active by default.

### Feedback value

The output signal is a function of the actual feedback value.

Min: Minimum feedback (0/4 mA).

Max: Maximum feedback (20 mA).

Scaling: Linear.

### Speed

The output signal is a function of the actual pump speed.

Min: 0 rpm.

Max: Speed according to maximum frequency.

Scaling: Linear.

### Frequency

The output signal is a function of the actual frequency.

Min: 0 rpm.

Max: Maximum frequency.

Scaling: Linear.

### Motor current

The output signal is a function of the actual motor current.

Min: 0 A.

Max: 2 x nominal motor current.

Scaling: Linear.

### External setpoint input

The output signal is a function of the external setpoint input.

Min: 0 V.

Max: 10 V.

Scaling: Linear.

### Limit exceeded

The output signal indicates whether the limit is exceeded:

Min: Limit not exceeded (0 mA).

Max: Limit exceeded (20 mA).

Scaling: On/off.

Default setting is NOT ACTIVE.

## GENIbus

The CUE supports serial communication via the RS-485 connection. The communication enables connection to a building management system or another external control system.

Operating parameters such as setpoint and operating mode can be remotely set via the bus signal. At the same time, the pump can provide status information about important parameters such as actual value of control parameter, input power and fault indications.

### Protocol

When using the GENIbus interface, the protocol selection of the RS-485 port must be set to GENIbus, and the communication must be set according to the Grundfos GENIbus standard.

### Pump number

When using the GENIbus interface, a pump number between 1 and 199 must be allocated to each pump via the control panel.

## Local/remote operating mode

In local operating mode, the unit is controlled from local sources, i.e. control panel and digital input.

In remote operating mode, the unit is controlled via GENIbus. Change to remote operating mode is done via GENIbus.

### Priority of settings

The CUE can be controlled in various ways at the same time. If two or more operating modes are active at the same time, the operating mode with the highest priority will be in force.

### Local operating mode

Priority	CUE menu	External signal
1	Stop	
2	Max.	
3		Stop
4		Max.
5	Min.	Min.
6	Normal	Normal

**Example:** If an external signal has activated the "Max." operating mode, it will only be possible to stop the pump.

### Remote operating mode

Priority	CUE menu	External signal	Bus signal
1	Stop		
2	Max.		
3		Stop	Stop
4			Max.
5			Min.
6			Normal

**Example:** If the bus signal has activated the "Max." operating mode, it will only be possible to stop the pump.

## MCB 114 sensor input module

The MCB 114 sensor input module offers three additional analog inputs for the CUE:

- one analog 0/4-20 mA input for an additional sensor
- two analog Pt100/Pt1000 inputs for temperature sensors.

### Sensor 2

The analog 0/4-20 mA input is used for these functions:

- Monitoring of measured value of sensor 2 (default setting).
- Measured value of sensor 2 used for control purpose. This makes differential pressure control possible by using measurements from sensor 1 and sensor 2 (setting by means of PC Tool).

### Temperature sensors 1 and 2

The analog Pt100/Pt1000 inputs are used for monitoring of these temperatures:

- drive-end motor bearing
- non-drive-end motor bearing
- other liquid 1
- other liquid 2
- motor windings
- pumped liquid
- ambient temperature.

### Displays

MCB 114 input	Displays	
	Reading	Setting
Sensor 2	2.5	3.16
Temperature sensor 1	2.12	3.21
Temperature sensor 2	2.13	3.22

### Further information

See section [MCB 114 sensor input module](#), page 60.

See also the CUE and MCB 114 installation and operating instructions.



## 7. Installation

### Mechanical installation

The CUE cabinet sizes are characterized by their enclosure. The CUE is available in four enclosure classes, IP20, IP21, IP54 and IP55. To see the relationship of enclosure class and enclosure type, see tables starting on page 44.

The general installation requirements necessitate special considerations as to these aspects:

- Accessible, but only in a cabinet. Enclosure class IP20/21 must not be installed freely.
- Enclosure class IP54/55 must be installed freely accessible, but must not be installed outdoors without additional protection against water and the sun.
- The CUE contains a large number of mechanical and electronic components and must therefore not be installed in an environment where the air contains liquids, particles or gasses which may affect and damage the electronic components.
- In applications requiring Ex approval, the CUE should be installed outside the hazardous area.
- Special care must be taken to ensure that the installation is covered by the correct Ex rating.

### Space requirements and air circulation

CUE units can be mounted side by side, but as sufficient air circulation is required for cooling, these requirements must be met:

- Sufficient free space above and below the CUE. See table below.
- Hang the CUE directly on the wall, or fit it with a back plate to secure sufficient air flow for cooling. See fig. 37.

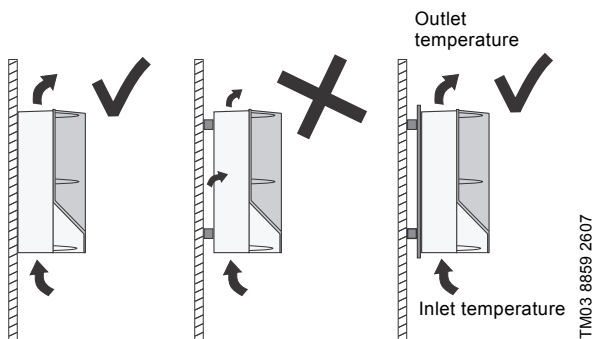

Fig. 37 CUE hung directly on the wall or fitted with a back plate

### Required free space above and below the CUE

Enclosure	Space [in. (mm)]
A2, A3, A4, A5	4 (100)
B1, B2, B3, B4, C1, C3	8 (200)
C2, C4, D1h, D2h	9 (225)

### Required free space in front of the CUE

Furthermore, there must be sufficient space in front of the CUE for opening the door of the CUE. See fig. 38.

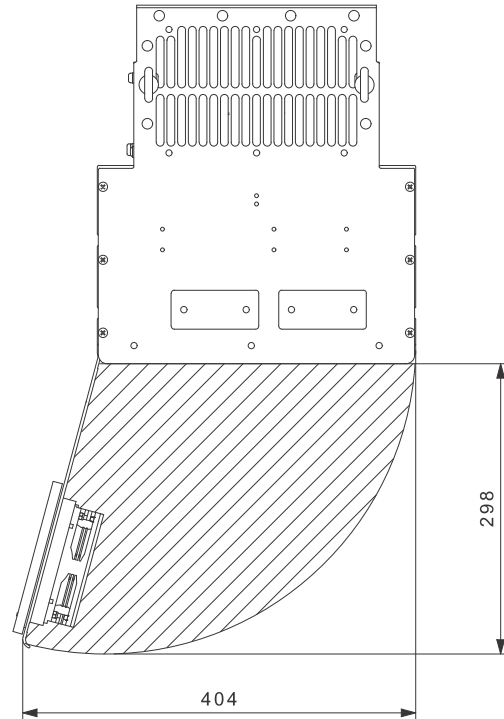

Fig. 38 Free space in front of CUE enclosures D1h and D2h

TM05 9324 3713

TM03 8859 2607

## Ventilation of built-in CUE

The CUE can be mounted in a control cabinet if sufficient air circulation is ensured. The quantity of air flow required for cooling the CUE can be calculated as follows:

$$q_v = \frac{\Sigma P \times 3.285}{\Delta T} \text{ [ft}^3\text{/min]}$$

Insert  $\Sigma P$  in Watt and  $\Delta T$  in °F.

$\Sigma P$  is the power loss of all equipment integrated in the same cabinet. Calculate the power loss P of the CUE by means of the typical shaft power P2 multiplied by the efficiency.

$\Delta T$  is the difference between the outlet temperature and the inlet temperature (ambient) of the cooling air. See fig. 37.

**Note:** The inlet and outlet temperatures must not be higher than the values in the table below.

	Max. inlet temperature	Max. outlet temperature
CUE .75-125 Hp (0.55 - 90 kW)	122 °F (50 °C)	131 °F (55 °C)
CUE 150-350 Hp (110-250 kW)	113 °F (45 °C)	122 °F (50 °C)

The average inlet temperature over 24 hours must be 9 °F (5 °C) lower.

The outlet from the ventilation must be placed above the highest-mounted CUE. Allowance must be made for the pressure loss across the inlet filters of the control panel and for the fact that the pressure will drop as the filters get choked.

### Example

Calculate the required air flow for cooling of a built-in CUE when the ambient temperature is 80 °F (27 °C). The CUE has a typical shaft power of 11 kW and an efficiency of 0.98. See page 46.

Calculate the power loss of the CUE:

$$P = P_2 \times \text{efficiency} = 11.0 \times (1 - 0.98) \times 1000 = 220 \text{ W.}$$

Calculate the required air flow for cooling the CUE:

$$q_v = (P \times 3.285) / (\Delta T) = (220 \times 3.285) / (131 - 80) = 14.2 \text{ ft}^3\text{/min.}$$

## Electrical installation

**Note:** Always observe national and local regulations as to cable cross-section, short-circuit protection and overcurrent when installing the CUE.

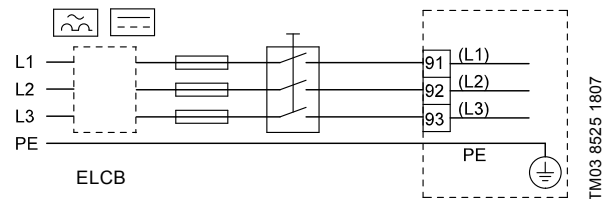

**Fig. 39** Example of three-phase power supply connection of the CUE with power supply switch, backup fuses and additional protection

## Electrical protection

### Protection against electric shock, indirect contact

Protective conductors must always have a yellow/green (PE) or yellow/green/blue (PEN) color marking. Instructions according to EN IEC 61800-5-1:

- The CUE must be stationary, installed permanently and connected permanently to the power supply.
- The ground connection must be carried out with duplicate protective conductors or with a single reinforced protective conductor with a cross-section of minimum 10 mm<sup>2</sup>.

### Protection against short-circuit, fuses

The CUE and the supply system must be protected against short-circuit.

Grundfos demands that the fuses mentioned on page 54 are used for protection against short-circuit.

### Protection against short-circuit on the motor output

The CUE offers complete short-circuit protection in case of a short-circuit on the motor output.

### Additional protection

**Note:** The leakage current to ground exceeds 3.5 mA.

If the CUE is connected to an electrical installation where an earth leakage circuit breaker (ELCB) is used as additional protection, the circuit breaker must be of a type marked with the following symbols:

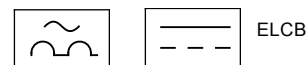

The circuit breaker is type B.

The total leakage current of all the electrical equipment in the installation must be taken into account.

Leakage current of the CUE in normal operation, see page 53. During start and in asymmetrical supply systems, the leakage current can be higher than normal and may cause the ELCB to trip.

### Motor protection

The motor requires no external motor protection. The CUE protects the motor against thermal overloading and blocking.

### Protection against overcurrent

The CUE has an internal overcurrent protection for overload protection on the motor output.

### Protection against power supply voltage transients

The CUE is protected against power supply voltage transients according to EN 61800-3, second environment.

### Total harmonic distortion

A variable frequency drive takes up a non-sinusoidal current from the power supply. A non-sinusoidal current results in increased heat losses in cables and transformers. The total harmonic distortion (THD) is defined as the sum of the higher-order current components compared to the fundamental current components (50 or 60 Hz).

The CUE is equipped with intermediate coils to reduce the total harmonic distortion. The use of coils has a considerable effect on the THD; in addition, the installation site conditions are also an influencing factor on THD.

The typical THD value for CUE is in the range of 40 to 50 %. The following standards cover THD:

- IEC EN 61000-3-2, Class A, for three-phase balanced equipment (for professional equipment only up to 1.5 Hp (1 kW) total power)
- IEC EN 61000-3-12, Equipment 16 A - 75 A, and professional equipment as from 1.5 Hp (1 kW) up to 16 A per phase current.

The CUE complies with the following standards:

- 0 - 1 Hp (0 - 0.75 kW): 3 x 200 V and 3 x 380-500 V comply with IEC EN 61000-3-2.
- 1.5 - 24 Hp (1.1 - 18 kW): 3 x 200 V complies with IEC/EN 61000-3-12.
- 1.5 - 120 Hp (1.1 - 90 kW): 3 x 380-500 V complies with IEC/EN 61000-3-12.
- 150 - 335 Hp (110 - 250 kW): 3 x 380-500 V complies with IEC/EN 61000-3-12. The standard originally covers only up to 75 A output current.

Other voltages and power ranges are not covered by standards.

### Power supply and motor connection

The supply voltage and frequency are marked on the CUE nameplate. Make sure that the CUE is suitable for the power supply of the installation site.

### Power supply switch

A power supply switch can be installed before the CUE according to local regulations. See fig. 39.

### Wiring diagram

The wires in the terminal box must be as short as possible. Excepted from this is the protective conductor which must be so long that it is the last one to be disconnected in case the cable is inadvertently pulled out of the cable entry.

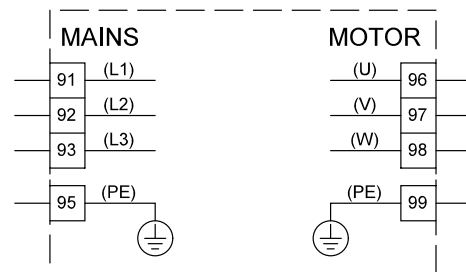

Fig. 40 Wiring diagram, three-phase power supply connection

Terminal	Function
91 (L1)	Three-phase supply
92 (L2)	
93 (L3)	
95/99 (PE)	Ground connection
96 (U)	Three-phase motor connection, 0-100 % of power supply voltage
97 (V)	
98 (W)	

**Note:** Use terminals 91 (L1) and 92 (L2) for single-phase CUE variable frequency drives (1 x 200-240 V).

### Connecting the signal terminals

**Note:** As a precaution, signal cables must be separated from other groups by reinforced insulation in their entire lengths.

**Note:** If no external on/off switch is connected, short-circuit terminals 18 and 20 using a short wire.

## Wiring diagram, signal terminals

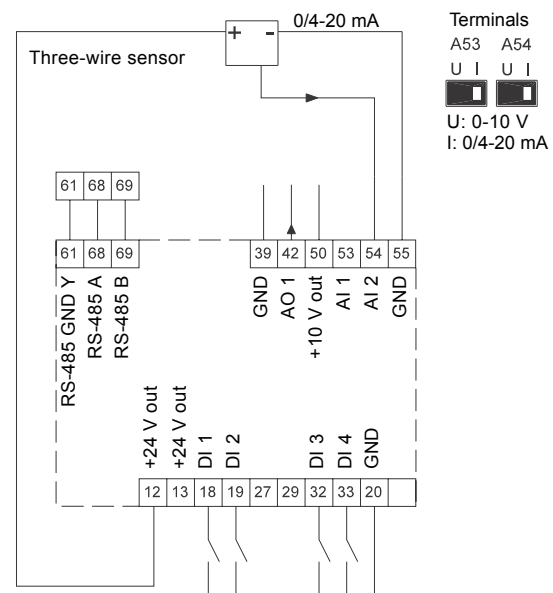
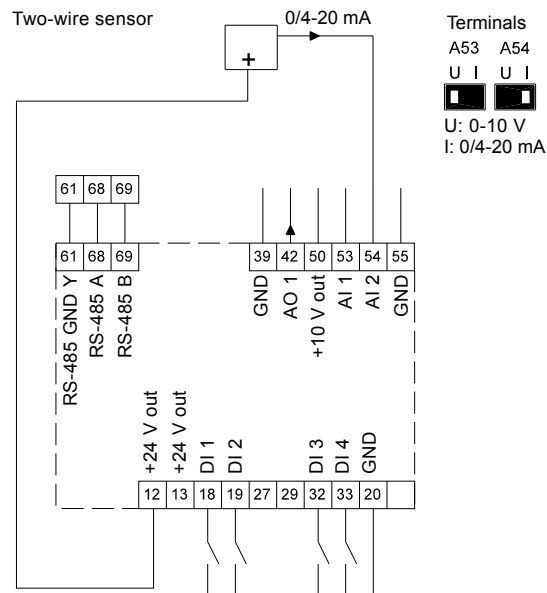
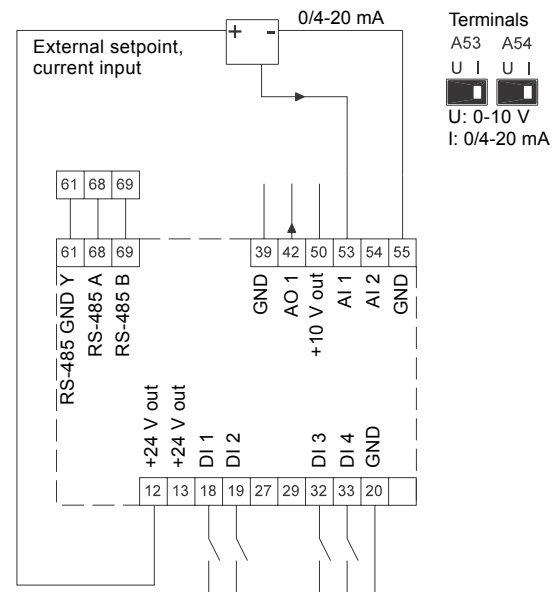
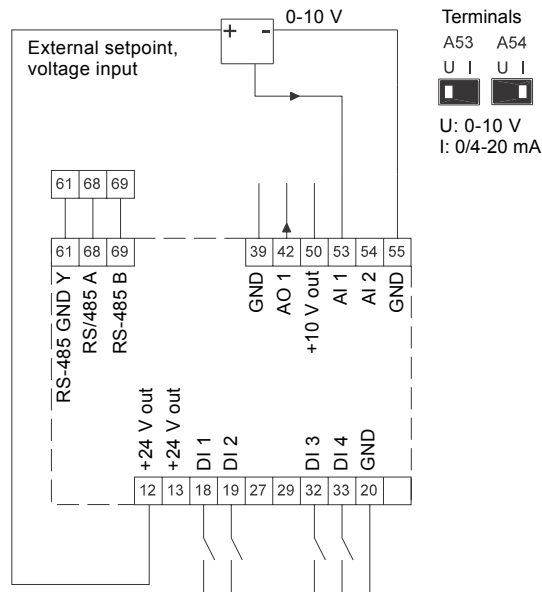

Terminal	Type	Function	Terminal	Type	Function
12	+24 V out	Supply to sensor	42	AO 1	Analog output, 0-20 mA
13	+24 V out	Additional supply	50	+10 V out	Supply to potentiometer
18	DI 1	Digital input, start/stop	53	AI 1	External setpoint, 0-10 V, 0/4-20 mA
19	DI 2	Digital input, programmable	54	AI 2	Sensor input, sensor 1, 0/4-20 mA
20	GND	Common frame for digital inputs	55	GND	Common frame for analog inputs
32	DI 3	Digital input, programmable	61	RS-485 GND Y	GENIBus, frame
33	DI 4	Digital input, programmable	68	RS-485 A	GENIBus, signal A (+)
39	GND	Frame for analog output	69	RS-485 B	GENIBus, signal B (-)

Terminals 27 and 29 are not used.

**Note:** The RS-485 screen must be connected to frame.

Connect the signal cables according to the guidelines for good practice to ensure EMC-correct installation. See section [EMC-correct installation](#), page 39.

- Use screened signal cables with a conductor cross-section of min. 0.5 mm<sup>2</sup> and max. 1.5 mm<sup>2</sup>.

Use a 3-conductor screened bus cable in new systems.

## RFI filters

To meet the EMC requirements in EN 61800-3, the CUE comes with the following types of built-in radio frequency interference filter (RFI).

Voltage [V]	Typical shaft power P2 [Hp (kW)]	RFI filter type
1 x 200-240	1.5 - 10 (1.1 - 7.5)	C1
3 x 200-240	1 - 60 (0.75 - 45)	C1
3 x 380-500	0.75 - 125 (0.55 - 90)	C1
	150 - 350 (110 - 250)	C3
3 x 525-600	1 - 10 (0.75 - 7.5)	C3
3 x 525-690	15 - 350 (11 - 250)	C3

RFI filter types are according to EN 61800-3.

C1 is a high-performance filter. C3 are typically RFI filter types for standard variable frequency drives.

### Description of RFI filter types

C1: For use in domestic areas.

C3: For use in industrial areas with own low-voltage transformer.

#### Equipment of category C3

- This type of power drive system (PDS) is not intended to be used on a low-voltage public network which supplies domestic premises.
- Radio frequency interference is to be expected if used on such a network.

## Output filters

Output filters are used for reducing the voltage stress on the motor windings and the stress on the motor insulation system as well as for decreasing acoustic noise from the variable frequency drive-driven motor.

Grundfos offers two types of output filter as accessories for the CUE:

- dU/dt filters
- sine-wave filters.

The filters are IP20/NEMA1 enclosure.

### dU/dt filters

dU/dt filters reduce the voltage peaks and dU/dt of the pulses at the motor terminals. The voltage at the motor terminals is still pulse-shaped; the motor current has a sine-wave shape without commutation spikes.

### Sine-wave filters

Sine-wave filters have a higher degree of filtering, resulting in higher reduction of motor insulation stress and elimination of switching acoustic noise from the motor.

The motor losses are reduced because the motor is fed with a sine-wave voltage. Moreover, the filter eliminates the pulse reflections in the motor cable and thus reduces the losses in the motor.

## Use of output filters

The table below explains in which cases an output filter is required. From the table it can be seen if a filter is needed, and which type to use.

The selection depends on:

- pump type
- motor cable length
- the required reduction of the acoustic noise from the motor.

Pump type	Typical shaft power P2	dU/dt filter [ft (m)]	Sine-wave filter [ft (m)]
SP, BM, BMB with 380 V motor and up	Up to 10 Hp	-	0-1000 (0-300)
	15 Hp and up	0-500 (0-150)	500-1000 (150-300)
Other pumps, noise reduction	Up to 10 Hp	-	0-1000 (0-300)
	15 Hp and up	0-500 (0-150)	500-1000 (150-300)
Other pumps, higher noise reduction	Up to 10 Hp	-	0-1000 (0-300)
	15 Hp and up	-	0-1000 (0-300)
Pumps with 690 V motor	All	0-500 (0-150)	500-1000 (150-300)

The lengths stated apply to the motor cable.

## Motor size 225 and larger

Grundfos recommends using insulated bearings in motor size 225 and larger.

## Motor cable

**Note:** The motor cable must always be a screened cable no matter if an output filter is installed or not. The power supply cable need not be a screened cable. See figures 41 and 42.

Screened motor cable is required to comply with EN 61800-3.



TM04 4289 1109

Fig. 41 Example of installation without filter

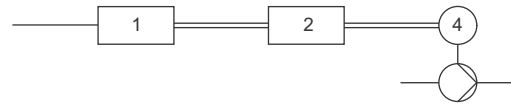

TM04 4290 1109

Fig. 42 Example of installation with filter. The cable between the CUE and filter must be short.

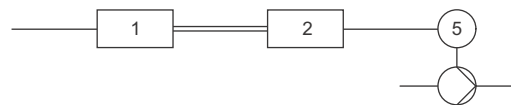

TM04 4291 1109

Fig. 43 Submersible pump without connection box. Variable frequency drive and filter installed close to the well.

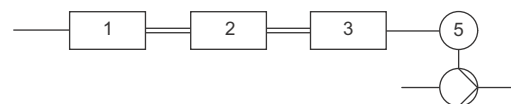

TM04 4292 1109

Fig. 44 Submersible pump with connection box and screened cable. Variable frequency drive and filter installed far away from the well.

Symbol	Designation
1	CUE
2	Filter
3	Connection box
4	Standard motor
5	Submersible motor
One line	Unscreened cable
Double line	Screened cable

### EMC-correct installation

This section gives guidelines for good practice when installing the CUE. Follow these guidelines to comply with EN 61800-3, first environment.

- Use only motor and signal cables with a braided metal screen in applications without output filter.
- There are no special requirements to supply cables, apart from local requirements.
- Leave the screen as close to the connecting terminals as possible. See fig. 45.
- Avoid terminating the screen by twisting the ends. See fig. 46. Use cable clamps or EMC screwed cable entries instead.
- Connect the screen to frame at both ends for both motor and signal cables. See fig. 47. If the controller has no cable clamps, connect only the screen to the CUE. See fig. 48.
- Avoid unscreened motor and signal cables in electrical cabinets with variable frequency drives.
- Make the motor cable as short as possible in applications without output filter to limit the noise level and minimise leakage currents.
- Screws for frame connections must always be tightened whether a cable is connected or not.
- Keep main cables, motor cables and signal cables separated in the installation, if possible.

Other installation methods may give similar EMC results if the above guidelines for good practice are followed.

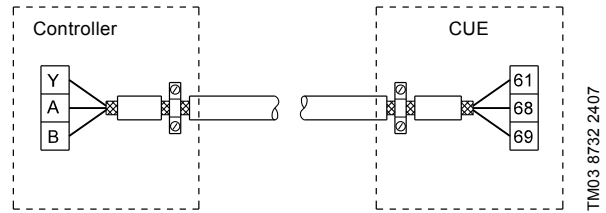

Fig. 47 Example of connection of a 3-conductor bus cable with screen connected at both ends

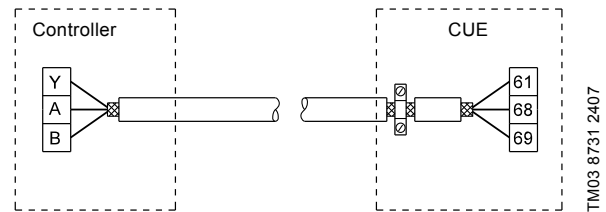

Fig. 48 Example of connection of a 3-conductor bus cable with screen connected at the CUE (controller with no cable clamps)

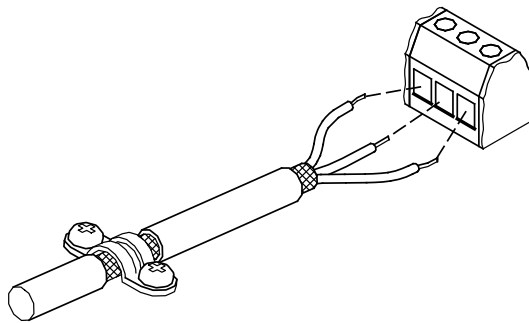

Fig. 45 Example of stripped cable with screen

TM02 1325 0901

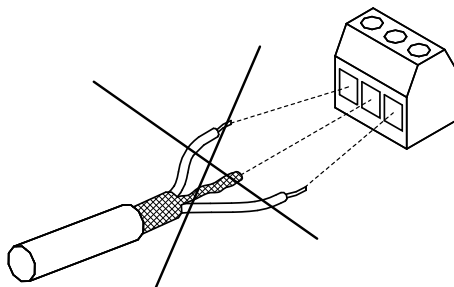

Fig. 46 Do not twist the screen ends.

TM03 8812 2507

## 8. Operation

### Control panel

The control panel is used for local setting of the CUE. The functions available depend on the pump family.

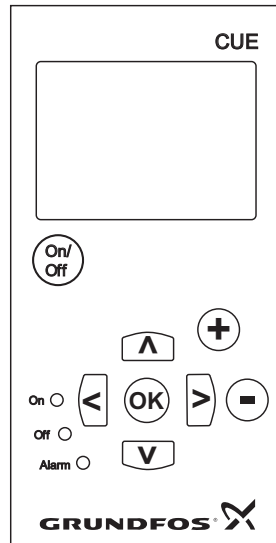

TM03 8719 2507

Fig. 49 Control panel of the CUE

#### Editing buttons

Button	Function
	Makes the pump ready for operation/starts and stops the pump.
	Saves changed values, resets alarms and expands the value field.
	Changes values in the value field.

#### Navigating buttons

Button	Function
	Navigates from one menu to another. When the menu is changed, the display shown will always be the top display of the new menu.
	Navigates up and down in the individual menu.

#### Indicator lights

The operating condition of the pump is indicated by the indicator lights on the front of the control panel. See fig. 49.

The table shows the function of the indicator lights.

Indicator light	Function
On (green)	The pump is running or has been stopped by a stop function. If flashing, the pump has been stopped by the user (CUE menu), external start/stop or bus.
Off (orange)	The pump has been stopped with the on/off button.
Alarm (red)	Indicates an alarm or a warning.

### Startup guide

Use the startup guide for general setting of the CUE, including setting of the correct direction of rotation.

The startup guide will be started the first time the CUE is connected to supply voltage. It can be restarted from the "GENERAL" menu. Please note that, in that case, all previous settings will be erased.

### CUE settings document



TM04 7313 1810

This document includes all parameters that can be set on the CUE using the Grundfos Local Control Panel.

The document includes a special table for additional PC Tool settings and a page for entering special PC Tool programming details.

For downloading of the document, please contact your local Grundfos company.



## Warning and alarm list

Code and display text	Status			Operating mode	Resetting
	Warning	Alarm	Locked alarm		
1 Too high leakage current			•	Stop	Manual
2 Power supply phase failure		•		Stop	Auto
3 External fault		•		Stop	Manual
16 Other fault		•		Stop	Auto
			•	Stop	Manual
30 Replace motor bearings	•			-	Manual <sup>3)</sup>
32 Overvoltage	•			-	Auto
		•		Stop	Auto
40 Undervoltage	•			-	Auto
		•		Stop	Auto
48 Overload			•	Stop	Manual
49 Overload		•		Stop	Auto
55 Overload	•			-	Auto
		•		Stop	Auto
57 Dry running		•		Stop	Auto
64 Too high CUE temperature		•		Stop	Auto
70 Too high motor temperature		•		Stop	Auto
77 Communication fault, duty/standby	•			-	Auto
89 Sensor 1 outside range		•		1)	Auto
91 Temperature sensor 1 outside range	•			-	Auto
93 Sensor 2 outside range	•			-	Auto
96 Setpoint signal outside range		•		1)	Auto
148 Too high bearing temperature	•			-	Auto
		•		Stop	Auto
149 Too high bearing temperature	•			-	Auto
		•		Stop	Auto
155 Inrush fault		•		Stop	Auto
175 Temperature sensor 2 outside range	•			-	Auto
240 Relubricate motor bearings	•			-	Manual <sup>3)</sup>
	•			-	Auto
241 Motor phase failure		•		Stop	Auto
242 AMA did not succeed <sup>2)</sup>	•			-	Manual

1) In case of an alarm, the CUE will change the operating mode, depending on the pump type.

2) Automatic motor adaptation.

3) Warning is reset in display 3.20.

In case of fault or malfunction of the CUE, the latest five warnings and latest five alarms can be found in the log menus.

## Warning

The CUE will continue operating as long as the warning is active. The warning re active until the cause no longer exists. Some warnings may switch to alarm condition if the warning has been present for a period.

## Alarm

In case of an alarm, the CUE will stop the pump or change the operating mode, depending on the alarm type and pump type.

Pump operation will be resumed when the cause of the alarm has been remedied and the alarm has been reset.

### Resetting an alarm manually

- Press [OK] in the alarm display.
- Press [On]/[Off] twice.
- Activate a digital input DI 2-DI 4 set to "Alarm reset" or the digital input DI 1 (start/stop).

If it is not possible to reset an alarm, the reason may be that the fault has not been remedied, or that the alarm has been locked.

### Locked alarm

In case of a locked alarm, the CUE will stop the pump and become locked. Pump operation cannot be resumed until the cause of the locked alarm has been remedied and the alarm has been reset.

### Resetting a locked alarm

- Switch off the power supply to the CUE for approx. 30 seconds.
- Switch on the power supply, and press [OK] in the alarm display to reset the alarm.

## 9. CUE selection

### How to select a CUE

The size of the CUE is determined quickly and precisely based on the max. motor current. See fig. 50.

The power size, which is the typical shaft power  $P_2$ , is only an approximate value and cannot be used for selecting the nominal size of the CUE.

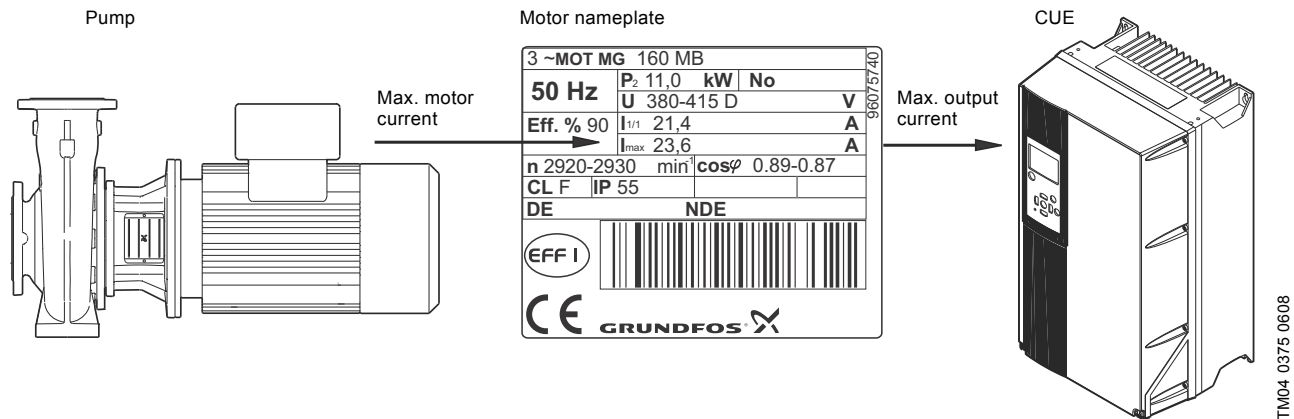

Fig. 50 Selection of CUE based on max. motor current

### The main steps

When you have selected the pump, follow these steps to select a CUE:

1. Select the voltage range of the CUE. It should fit the motor voltage and the power supply at the installation site.
2. Find the max. motor current on the motor nameplate or in the data sheet of the selected motor. Select the first CUE that is able to deliver the max. motor current. See selection tables starting on page 44.
3. Check that the output power rating (kW/hp) as a minimum corresponds to the value stated on the motor nameplate.
4. Select the enclosure class. Choose IP20/21 for panel mounting and IP54/55 for wall mounting. See selection tables starting on page 44.

Select standard gland holes for CUEs used outside the USA and Canada.

Select imperial gland holes for CUEs used in USA and Canada.

5. Check if an output filter is required. Select the output filter according to the table on page 37.
6. Select the accessories required for the application. It could be sensors or additional input modules.

Selecting the different accessories may require additional steps.

**Note:** The actual motor current should always be less or equal to the motor current selected in the control panel of the CUE.

If not, the CUE will reduce the maximum speed when the maximum limit is reached during operation.

#### Example 1

Data:

- Voltage range is 3 x 400 V.
- Max. motor current is 23.6 A. See fig. 50.
- Enclosure class of the CUE must be IP21.

Select the CUE according to the selection tables on page 46.

Data of the CUE selected:

Max. output current:	27.0 A
Typical shaft power:	15 Hp / 11.0 kW
Product number (IP21):	91136772

**Note:** Technical data can be found on page 50.

## Special conditions

Derating must be taken into account when using the CUE in these situations:

- low air pressure (heights)
- low speeds
- installations with long motor cables
- cables with a large cross-section
- high ambient temperature.

The required action is described in the next sections.

### Low air pressure

At low air pressure, the cooling capability of air is reduced.

At altitudes above 3280 ft (1000 m), the max. output current should be derated in accordance with the diagram in fig. 51.

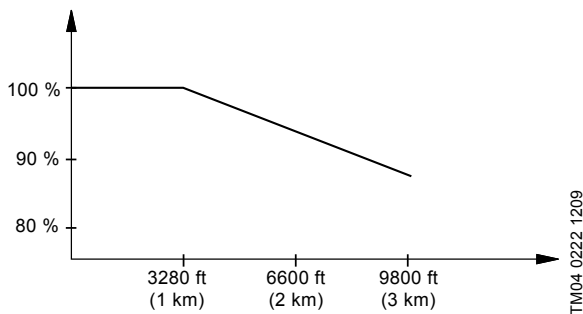

**Fig. 51** Derating of output current at low air pressure

At altitudes above 6561 ft (2000 m), PELV cannot be met.

PELV = Protective Extra Low Voltage.

An alternative is to lower the ambient temperature at high altitudes and thereby ensure 100 % output current at high altitudes.

### Example 2

At an altitude of 6600 ft (2000 m), the output current 24.0 A of the selected CUE in Example 1 must be derated to 92 % according to fig. 51. This is equal to 22.1 A and lower than the max. motor current 23.6 A. The selection is not valid.

## High ambient temperature

If the output current is reduced to 80 % of the nominal output current of the CUE in question, the ambient temperature may be 9 °F (5 °C) higher.

The other possibility is to use a unit one size bigger. For higher temperature increases, bigger units are required. The efficiency of the CUE will, however, be reduced at higher temperatures.

If the CUE gets too hot, it will reduce the switching frequency.

Note that the nominal temperature rating depends on the enclosure type.

The maximum ambient temperature of the different enclosures can be found in [Technical data](#), page 50.

## Selection tables

### Power supply 1 x 200-240 V (output 3 x 200-240 V)

Typical shaft power P2		Maximum output current [A]	Maximum input current [A]	Enclosure				Maximum conductor cross-section		Efficiency
[Hp]	[kW]	3 x 200-240 V	1 x 200-240 V	IP20	IP21	IP54	IP55	AWG	[mm <sup>2</sup> ]	
1.5	1.1	6.6	12.5	A3	-	-	A5	10	4	0.96
2	1.5	7.5	15.0	-	-	-	-	7	10	0.96
3	2.2	10.6	20.5	-	-	-	-	7	10	0.96
4	3	12.5	24	-	B1	-	B1	7	10	0.96
5	3.7	16.7	32	-	-	-	-	7	10	0.96
7.5	5.5	24.2	46	-	B1	-	B1	7	10	0.98
10	7.5	30.8	59	-	B2	-	B2	2	35	0.98

Note: CUEs with single-phase input always have three-phase output.

### Standard gland holes, product numbers

Select standard gland holes for CUEs used outside the USA and Canada.

Typical shaft power P2		CUE			Output filter IP20	
[Hp]	[kW]	IP20	IP21	IP55	dU/dt	Sine-wave
1.5	1.1	96754460	-	96754481	-	96754973
2	1.5	-	96754461	96754502	-	96754973
3	2.2	-	96754472	96754503	-	96754976
4	3	-	96754473	96754505	-	96754976
5	3.7	-	96754474	96754506	-	96754976
7.5	5.5	-	96754475	96754507	-	96754977
10	7.5	-	96754476	96754509	-	96754978

### Imperial gland holes, product numbers

Select imperial gland holes for CUE used in the USA and in Canada.

Typical shaft power P2		CUE			Output filter IP20	
[Hp]	[kW]	IP20	IP21	IP55	dU/dt	Sine-wave
1.5	1.1	96754460	-	97749822	-	96754973
2	1.5	-	96754461	97749813	-	96754973
3	2.2	-	96754472	97749814	-	96754976
4	3	-	96754473	97749815	-	96754976
5	3.7	-	96754474	97749816	-	96754976
7.5	5.5	-	96754475	97749818	-	96754977
10	7.5	-	96754476	97749819	-	96754978

## Power supply 3 x 200-240 V

Typical shaft power P2		Maximum output current [A]	Maximum input current [A]	Enclosure				Maximum conductor cross-section		Efficiency
[Hp]	[kW]	3 x 200-240 V	3 x 200-240 V	IP20	IP21	IP54	IP55	AWG	[mm <sup>2</sup> ]	
1	0.75	4.6	4.1		-	-		10	4	0.95
1.5	1.1	6.6	5.9	A2	-	-	A4	10	4	0.96
2	1.5	7.5	6.8		-	-		10	4	0.96
3	2.2	10.6	9.5		-	-		10	4	0.96
4	3	12.5	11.3	A3	-	-	A5	10	4	0.96
5	3.7	16.7	15		-	-		10	4	0.96
7.5	5.5	24.2	22		-	-		7	10	0.96
10	7.5	30.8	28	B3	-	-	B1	7	10	0.96
15	11	46.2	42		-	-		7	10	0.96
20	15	59.4	54	B4	-	-	B2	2	35	0.96
25	18.5	74.8	68		-	-		1/0	50	0.96
30	22	88	80	C3	-	-	C1	1/0	50	0.97
40	30	115	104		-	-		1/0	50	0.97
50	37	143	130	C4	-	-	C2	4/0	95	0.97
60	45	170	154		-	-		250 MCM	120	0.97

## Standard gland holes, product numbers

Select standard gland holes for CUEs used outside the USA and Canada.

Typical shaft power P2		CUE		Output filter IP20	
[Hp]	[kW]	IP20	IP55	dU/dt	Sine-wave
1	0.75	96754515	97685255	-	96754973
1.5	1.1	96754517	97685257	-	96754973
2	1.5	96754520	97685258	-	96754973
3	2.2	96754532	97685259	-	96754976
4	3	96754533	96754632	-	96754976
5	3.7	96754535	96754633	-	96754976
7.5	5.5	96754536	96754634	97669799	96754977
10	7.5	96754538	96754635	97669799	96754978
15	11	96754539	96754637	97669869	96755019
20	15	96754552	96754639	97669869	96755021
25	18.5	96754553	96754640	97669869	96755032
30	22	96754555	96754641	97669869	97774436
40	30	96754557	96754645	97669902	97774436
50	37	96754559	96754647	97669902	97775142
60	45	96754616	96754648	97669902	97775142

## Imperial gland holes, product numbers

Select imperial gland holes for CUEs used in the USA and in Canada.

Typical shaft power P2		CUE		Output filter IP20	
[Hp]	[kW]	IP20	IP55	dU/dt	Sine-wave
1	0.75	96754515	97685255	-	96754973
1.5	1.1	96754517	97685257	-	96754973
2	1.5	96754520	97685258	-	96754973
3	2.2	96754532	97685259	-	96754976
4	3	96754533	97749828	-	96754976
5	3.7	96754535	97749829	-	96754976
7.5	5.5	96754536	97749830	97669799	96754977
10	7.5	96754538	97749832	97669799	96754978
15	11	96754539	97749833	97669869	96755019
20	15	96754552	97749834	97669869	96755021
25	18.5	96754553	96754640	97669869	96755032
30	22	96754555	96754641	97669869	97774436
40	30	96754557	96754645	97669902	97774436
50	37	96754559	96754647	97669902	97775142
60	45	96754616	96754648	97669902	97775142

Power supply 3 x 380-500 V

Typical shaft power P2		Maximum output current [A]		Maximum input current [A]		Enclosure				Maximum conductor cross-section		Efficiency
[Hp]	[kW]	3 x 380-440 V	3 x 441-500 V	3 x 380-440 V	3 x 441-500 V	IP20	IP21	IP54	IP55	AWG	[mm <sup>2</sup> ]	
0.75	0.55	1.8	1.6	1.6	1.4	-	-	-	-	10	4	0.95
1	0.75	2.4	2.1	2.2	1.9	-	-	-	-	10	4	0.96
1.5	1.1	3	2.7	2.7	2.7	-	-	-	-	10	4	0.96
2	1.5	4.1	3.4	3.7	3.1	A2	-	-	A4	10	4	0.97
3	2.2	5.6	4.8	5	4.3	-	-	-	-	10	4	0.97
4	3	7.2	6.3	6.5	5.7	-	-	-	-	10	4	0.97
5	4	10	8.2	9	7.4	-	-	-	-	10	4	0.97
7.5	5.5	13	11	11.7	9.9	A3	-	-	A5	10	4	0.97
10	7.5	16	14.5	14.4	13	-	-	-	-	10	4	0.97
15	11	24	21	22	19	-	-	-	-	7	10	0.98
20	15	32	27	29	25	B3	-	-	B1	7	10	0.98
25	18.5	37.5	34	34	31	-	-	-	-	7	10	0.98
30	22	44	40	40	36	-	-	-	-	2	35	0.98
40	30	61	52	55	47	B4	-	-	B2	2	35	0.98
50	37	73	65	66	59	-	-	-	-	1/0	50	0.98
60	45	90	80	82	73	-	-	-	-	1/0	50	0.98
75	55	106	105	96	95	C3	-	-	C1	1/0	50	0.98
100	75	147	130	133	118	-	-	-	-	4/0	95	0.98
125	90	177	160	161	145	C4	-	-	C2	250 MCM	120	0.99
150	110	212	190	204	183	-	D1h	D1h	-	2 x 2/0	2 x 70	0.98
200	132	260	240	251	231	-	-	-	-	2 x 2/0	2 x 70	0.98
250	160	315	302	304	291	-	-	-	-	2 x 350 MCM	2 x 185	0.98
300	200	395	361	381	348	-	D2h	D2h	-	2 x 350 MCM	2 x 185	0.98
350	250	480	443	463	427	-	-	-	-	2 x 350 MCM	2 x 185	0.98

Standard gland holes, product numbers

Select standard gland holes for CUEs used outside the USA and Canada.

Typical shaft power P2		CUE				Output filter IP20	
[Hp]	[kW]	IP20	IP21	IP54	IP55	dU/dt	Sine-wave
0.75	0.55	96754675	-	-	97685238	-	96754941
1	0.75	96754676	-	-	97685239	-	96754941
1.5	1.1	96754677	-	-	97685240	-	96754972
2	1.5	96754678	-	-	97685251	-	96754972
3	2.2	96754679	-	-	97685252	-	96754973
4	3	96754680	-	-	97685253	-	96754973
5	4	96754681	-	-	97685254	-	96754974
7.5	5.5	96754692	-	-	96754711	-	96754976
10	7.5	96754693	-	-	96754722	-	96754976
15	11	96754694	-	-	96754723	97669799	96754977
20	15	96754695	-	-	96754724	97669799	96754978
25	18.5	96754696	-	-	96754725	97669799	96754978
30	22	96754697	-	-	96754726	97669799	96755019
40	30	96754698	-	-	96754727	97669869	96755021
50	37	96754699	-	-	96754728	97669869	96755032
60	45	96754700	-	-	96754729	97669869	97774436
75	55	96754701	-	-	96754730	97669896	97774436
100	75	96754702	-	-	96754731	97669902	97775142
125	90	96754703	-	-	96754732	97669902	97775142
150	110	-	97942968	97942995	-	97669905	97775146
200	132	-	97942970	97942996	-	97669905	97775146
250	160	-	97942992	97942999	-	97669905	97775148
300	200	-	97942993	97943000	-	97669906	97775148
350	250	-	97942994	97943001	-	97669906	97775149

**Power supply 3 x 380-500 V****Imperial gland holes, product numbers**

Select imperial gland holes for CUEs used in the USA and in Canada.

Typical shaft power P2		CUE				Output filter IP20	
[Hp]	[kW]	IP20	IP21	IP54	IP55	dU/dt	Sine-wave
0.75	0.55	96754675	-	-	97685238	-	96754941
1	0.75	96754676	-	-	97685239	-	96754941
1.5	1.1	96754677	-	-	97685240	-	96754972
2	1.5	96754678	-	-	97685251	-	96754972
3	2.2	96754679	-	-	97685252	-	96754973
4	3	96754680	-	-	97685253	-	96754973
5	4	96754681	-	-	97685254	-	96754974
7.5	5.5	96754692	-	-	97749852	-	96754976
10	7.5	96754693	-	-	97749853	-	96754976
15	11	96754694	-	-	97749854	97669799	96754977
20	15	96754695	-	-	97749855	97669799	96754978
25	18.5	96754696	-	-	97749856	97669799	96754978
30	22	96754697	-	-	97749857	97669799	96755019
40	30	96754698	-	-	97749858	97669869	96755021
50	37	96754699	-	-	96754728	97669869	96755032
60	45	96754700	-	-	96754729	97669869	97774436
75	55	96754701	-	-	96754730	97669896	97774436
100	75	96754702	-	-	96754731	97669902	97775142
125	90	96754703	-	-	96754732	97669902	97775142
150	110	-	97942968	97942995	-	97669905	97775146
200	132	-	97942970	97942996	-	97669905	97775146
250	160	-	97942992	97942999	-	97669905	97775148
300	200	-	97942993	97943000	-	97669906	97775148
350	250	-	97942994	97943001	-	97669906	97775149

## Power supply 3 x 525-600 V

Typical shaft power P2		Maximum output current [A]			Maximum input current [A]		Enclosure				Maximum conductor cross-section		Efficiency
[Hp]	[kW]	3 x 525-550 V	3 x 550-600 V	3 x 525-600 V	IP20	IP21	IP54	IP55	AWG	[mm <sup>2</sup> ]			
1	0.75	1.8	1.7	1.7	A3	-	-	A5	10	4	0.97		
1.5	1.1	2.6	2.4	2.4		-	-		10	4	0.97		
2	1.5	2.9	2.7	2.7		-	-		10	4	0.97		
3	2.2	4.1	3.9	4.1		-	-		10	4	0.97		
4	3	5.2	4.9	5.2		-	-		10	4	0.97		
5	4	6.4	6.1	5.8		-	-		10	4	0.97		
7.5	5.5	9.5	9	8.6		-	-		10	4	0.97		
10	7.5	11.5	11	10.4		-	-		10	4	0.97		

## Standard gland holes, product numbers

Select standard gland holes for CUEs used outside the USA and Canada.

Typical shaft power P2		CUE		Output filter IP20		
[Hp]	[kW]	IP20	IP55	dU/dt	Sine-wave	
1	0.75	96754734	96754742	-	97775161	
1.5	1.1	96754735	96754743	-	97775161	
2	1.5	96754736	96754744	-	97775161	
3	2.2	96754737	96754745	-	97775161	
4	3	96754738	96754746	-	97775161	
5	4	96754739	96754747	-	97775161	
7.5	5.5	96754740	96754748	-	97775161	
10	7.5	96754741	96754749	-	97775161	

## Imperial gland holes, product numbers

Select imperial gland holes for CUEs used in the USA and in Canada.

Typical shaft power P2		CUE		Output filter IP20		
[Hp]	[kW]	IP20	IP55	dU/dt	Sine-wave	
1	0.75	96754734	97749859	-	97775161	
1.5	1.1	96754735	97749860	-	97775161	
2	1.5	96754736	97749862	-	97775161	
3	2.2	96754737	97749863	-	97775161	
4	3	96754738	97749865	-	97775161	
5	4	96754739	97749866	-	97775161	
7.5	5.5	96754740	97749867	-	97775161	
10	7.5	96754741	97749868	-	97775161	



**Power supply 3 x 525-690 V**

UL approval up to 600 VAC power supply

Typical shaft power P2		Maximum output current [A]		Maximum input current [A]		Enclosure				Maximum conductor cross-section		Efficiency
[Hp]	[kW]	3 x 550 V	3 x 575-690 V	3 x 550 V	3 x 575-690 V	IP20	IP21	IP54	IP55	AWG	[mm <sup>2</sup> ]	
15	11	14	13	15	15	-	-	-	-	1/0	35	0.98
20	15	19	18	19.5	19.5	-	-	-	-	1/0	35	0.98
25	18.5	23	22	24	24	-	B2	-	B2	1/0	35	0.98
30	22	28	27	29	29	-	-	-	-	1/0	35	0.98
40	30	36	34	36	36	-	-	-	-	1/0	35	0.98
50	37	43	41	49	49	-	-	-	-	1/0	95	0.98
60	45	54	52	59	59	-	-	-	-	1/0	95	0.98
75	55	65	62	71	71	-	C2	-	C2	1/0	95	0.98
100	75	87	83	87	87	-	-	-	-	1/0	95	0.98
125	90	105	100	99	99	-	-	-	-	1/0	95	0.98
150	110	137	131	130	124/128	-	-	-	-	2 x 2/0	2 x 70	0.98
200	132	162	155	158	151/155	-	D1h	D1h	-	2 x 2/0	2 x 70	0.98
250	160	201	192	198	189/197	-	-	-	-	2 x 2/0	2 x 70	0.98
300	200	253	242	245	224/240	-	-	-	-	2 x 350 MCM	2 x 185	0.98
350	250	303	290	299	286/296	-	D2h	D2h	-	2 x 350 MCM	2 x 185	0.98

**Standard gland holes, product numbers**

Select standard gland holes for CUEs used outside the USA and Canada.

Typical shaft power P2		CUE			Output filter IP20	
[Hp]	[kW]	IP21	IP54	IP55	dU/dt	Sine-wave
15	11	96754750	-	96754769	97669799	97775162
20	15	96754752	-	96754770	97669799	97775162
25	18.5	96754754	-	96754771	97669799	97775162
30	22	96754755	-	96754772	97669799	97775163
40	30	96754756	-	96754773	97669869	97775163
50	37	96754757	-	96754775	97669869	97775164
60	45	96754758	-	96754776	97669869	97775164
75	55	96754759	-	96754777	97669896	97775165
100	75	96754760	-	96754778	97669896	97775165
125	90	96754761	-	96754779	97669902	97775166
150	110	97943002	97943009	-	97669905	97775166
200	132	97943003	97943010	-	97669905	97775167
250	160	97943005	97943023	-	97669906	97775167
300	200	97943006	97943025	-	97669906	97775168
350	250	97943008	97943026	-	97899248	97775168

**Imperial gland holes, product numbers**

Select imperial gland holes for CUEs used in the USA and in Canada.

Typical shaft power P2		CUE			Output filter IP20	
[Hp]	[kW]	IP21	IP54	IP55	dU/dt	Sine-wave
15	11	96754750	-	97749869	97669799	97775162
20	15	96754752	-	97749870	97669799	97775162
25	18.5	96754754	-	97749871	97669799	97775162
30	22	96754755	-	98749872	97669799	97775163
40	30	96754756	-	97749873	97669869	97775163
50	37	96754757	-	96754775	97669869	97775164
60	45	96754758	-	96754776	97669869	97775164
75	55	96754759	-	96754777	97669896	97775165
100	75	96754760	-	96754778	97669896	97775165
125	90	96754761	-	96754779	97669902	97775166
150	110	97943002	97943009	-	97669905	97775166
200	132	97943003	97943010	-	97669905	97775167
250	160	97943005	97943023	-	97669906	97775167
300	200	97943006	97943025	-	97669906	97775168
350	250	97943008	97943026	-	97899248	97775168

# 10. Technical data

## Main dimensions and weight

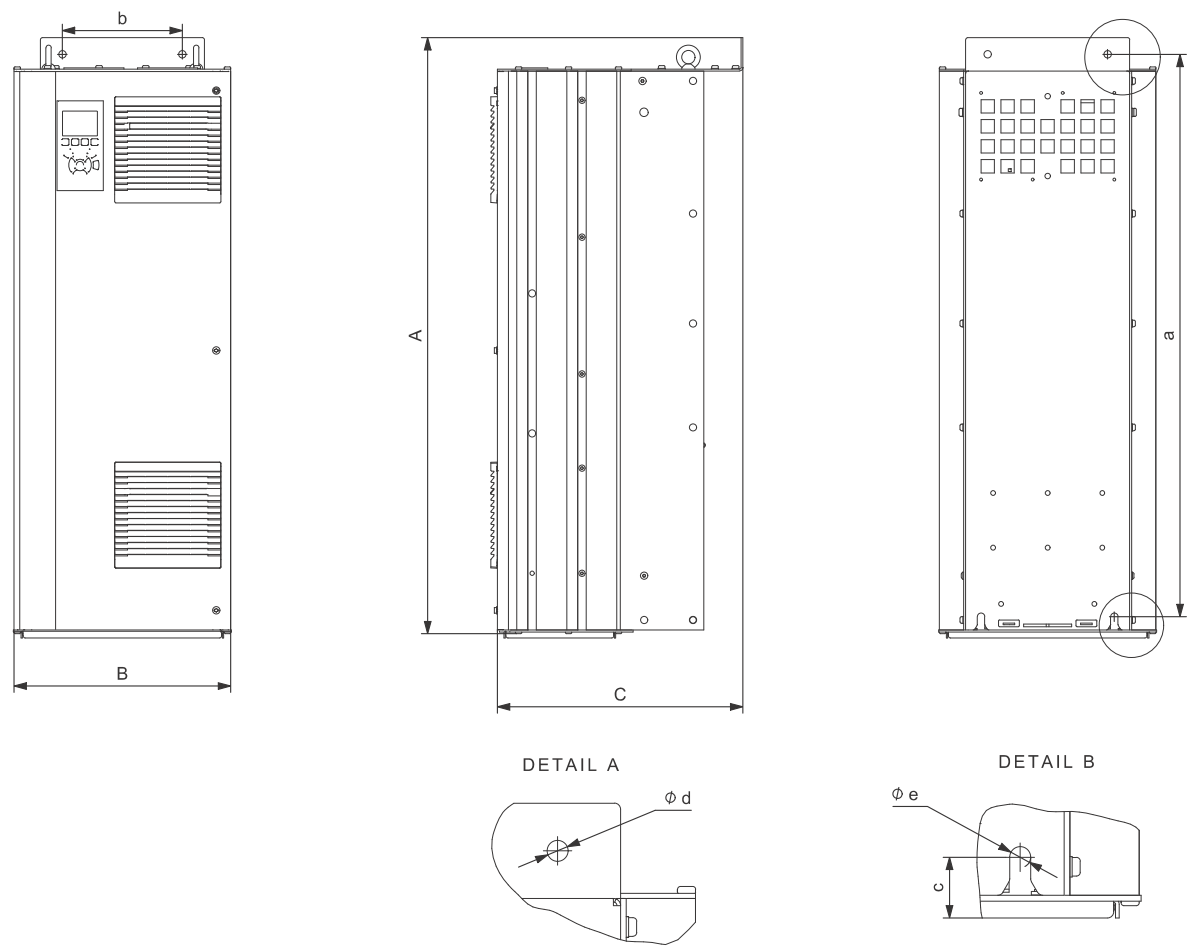

Fig. 52 Enclosures D1h and D2h

TM05 9331 3713

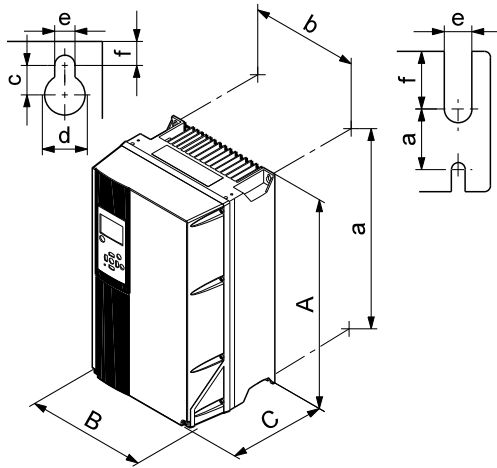

Fig. 53 Standard CUE

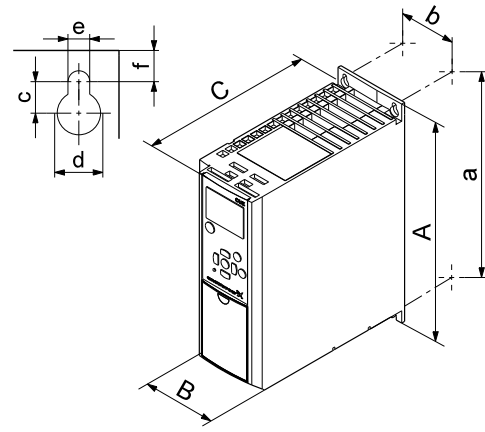

Fig. 54 CUE small

TM03 9002 2807

TM03 9000 2807

Enclosure	Height [in (mm)] <sup>1)</sup>		Width [in (mm)]		Depth [in (mm)]		Screw holes [in (mm)]			Weight [lb (kg)]	
	A	a	B	b	C	C <sup>1)</sup>	c	Ød	Øe		f
A2	10.55 (268)	10.12 (257)	3.54 (90)	2.76 (70)	8.08 (205)	8.62 (219)	.315 (8.0)	.433 (11)	.217 (5.5)	.354 (9.0)	10.8 (4.9)
with IP21/NEMA1 kit	14.76 (375)	13.78 (350)	3.54 (90)	2.76 (70)	8.08 (205)	8.62 (219)	.315 (8.0)	.433 (11)	.217 (5.5)	.354 (9.0)	11.7 (5.3)
A3	10.55 (268)	10.12 (257)	5.12 (130)	4.34 (110)	8.08 (205)	8.62 (219)	.315 (8.0)	.433 (11)	.217 (5.5)	.354 (9.0)	14.6 (6.6)
with IP21/NEMA1 kit	14.76 (375)	13.78 (350)	5.12 (130)	4.34 (110)	8.08 (205)	8.62 (219)	.315 (8.0)	.433 (11)	.217 (5.5)	.354 (9.0)	15.4 (7.0)
A4	16.54 (420)	15.79 (402)	7.87 (200)	6.73 (171)	6.89 (175)	6.89 (175)	0.32 (8.2)	0.47 (12)	0.26 (6.5)	0.24 (6)	20.7 (9.4)
A5	16.54 (420)	15.83 (402)	9.53 (242)	8.47 (215)	7.87 (200)	7.87 (200)	.323 (8.2)	.472 (12)	.256 (6.5)	.354 (9.0)	30.9 (14)
B1	18.90 (480)	17.87 (454)	9.53 (242)	8.27 (210)	10.24 (260)	10.24 (260)	.472 (12.0)	.748 (19)	.354 (9.0)	.354 (9.0)	26.5 (12)
B2	25.59 (650)	24.57 (624)	9.53 (242)	8.27 (210)	10.24 (260)	10.24 (260)	.472 (12.0)	.748 (19)	.354 (9.0)	.354 (9.0)	59.5 (27)
B3	15.71 (399)	14.96 (380)	6.50 (165)	5.52 (140)	9.76 (248)	10.32 (262)	.315 (8.0)	.472 (12)	.268 (6.8)	.311 (7.9)	26.5 (12)
with IP21/NEMA1 kit	18.71 (475)	-	6.50 (165)	-	9.80 (249)	10.32 (262)	.315 (8.0)	.472 (12)	.268 (6.8)	.311 (7.9)	- -
B4	20.47 (520)	19.49 (495)	9.09 in (231)	7.87 (200)	9.53 (242)	9.53 (242)	-	-	.335 (8.5)	.591 (15.0)	51.8 (23.5)
with IP21/NEMA1 kit	26.38 (670)	-	10.04 (255)	-	9.69 (246)	9.69 (246)	-	-	.335 (8.5)	.591 (15.0)	- -
C1	26.77 (680)	25.52 (648)	12.13 in (308)	10.71 (272)	12.21 (310)	12.21 (310)	.472 (12.0)	.748 (19)	.354 (9.0)	.386 (9.8)	99.2 (45)
C2	30.31 (770)	29.09 (739)	14.57 (370)	13.15 (334)	13.19 (335)	13.19 (335)	.472 (12.0)	.748 (19)	.354 (9.0)	.386 (9.8)	143.3 (65)
C3	21.65 (550)	20.51 (521)	12.13 (308)	10.63 (270)	13.11 (333)	13.11 (333)	-	-	.335 (8.5)	.669 (17.0)	77.2 (35)
with IP21/NEMA1 kit	21.65 (755)	-	12.95 (329)	-	13.27 (337)	13.27 (337)	-	-	.335 (8.5)	.669 (17.0)	- -
C4	25.98 (660)	24.84 (631)	14.57 (370)	12.99 (330)	13.11 (333)	13.11 (333)	-	-	.335 (8.5)	.669 (17.0)	110.2 (50)
with IP21/NEMA1 kit	37.40 (950)	-	15.39 (391)	-	13.27 (337)	13.27 (337)	-	-	.335 (8.5)	.669 (17.0)	- -
D1h	47.60 (1209)	45.43 (1154)	16.54 (420)	11.97 (304)	14.96 (380)	-	.787 (20)	.433 (11)	.433 (11)	.984 (25)	229.3 (104)
D2h	62.56 (1589)	60.43 (1535)	16.54 (420)	11.97 (304)	14.96 (380)	-	.787 (20)	.433 (11)	.433 (11)	.984 (25)	332.9 (151)

**Note:** Dimensions are maximum height, width, and depth.

<sup>1)</sup> Depth with MCB 114 option.

Shipping dimensions of D1h and D2h: height x width x length = 25.6 x 22.5 x 68.2 in. (650 x 570 x 1730 mm).

## Surroundings

Relative humidity	5-95 % RH
Minimum ambient temperature at full operation	32 °F (0 °C)
Minimum ambient temperature at reduced operation	14 °F (-10 °C)
Temperature during storage and transportation	-13 °F to 149 °F (-25 to 65 °C)
Storage duration	Max. 6 months
Maximum altitude above sea level with full performance	3,280 ft (1 km)
Maximum altitude above sea level with performance reduction	6,600 ft (2 km)
<b>CUE, up to 160 amps</b>	
Ambient temperature	Max. 122 °F (50 °C)
Average ambient temperature over 24 hours	Max. 113 °F (45 °C)
<b>CUE, 190 amps and above</b>	
Ambient temperature	Max. 113 °F (45 °C)
Average ambient temperature over 24 hours	Max. 104 °F (40 °C)

**Note:** The CUE comes in packaging which is not suitable for outdoor storage.

## Sound pressure level

Maximum sound pressure level measured at a distance of 3.28 ft (1 m) from the unit:

Enclosure	Sound pressure level [dB(A)]
A2	60
A3	60
A4	55
A5	63
B1	67
B2	70
B3	63 <sup>1)</sup>
B4	63
C1	62
C2	65
C3	67
C4	-
D1h	76
D2h	74

<sup>1)</sup> The sound pressure level for B3 in the 3 x 525-600 V range is 70 dB(A).

The sound pressure level of a motor controlled by a variable frequency drive may be higher than that of a corresponding motor which is not controlled by a variable frequency drive.

## Torques for terminals

Enclosure	Torque [ft-lb (Nm)]			
	Power supply	Motor	Ground	Relay
A2	1.3 (1.8)	(1.8)	2.2 (3)	0.4 (0.6)
A3	1.3 (1.8)	(1.8)	2.2 (3)	0.4 (0.6)
A4	1.3 (1.8)	(1.8)	2.2 (3)	0.4 (0.6)
A5	1.3 (1.8)	(1.8)	2.2 (3)	0.4 (0.6)
B1	1.3 (1.8)	(1.8)	2.2 (3)	0.4 (0.6)
B2	3.3 (4.5)	(4.5)	2.2 (3)	0.4 (0.6)
B3	1.3 (1.8)	(1.8)	2.2 (3)	0.4 (0.6)
B4	3.3 (4.5)	(4.5)	2.2 (3)	0.4 (0.6)
C1	7.4 (10)	(10)	2.2 (3)	0.4 (0.6)
C2	10.3 (14) <sup>1)</sup> / 17.7 (24) <sup>2)</sup>	10.3 (14) <sup>1)</sup> / 17.7 (24) <sup>2)</sup>	2.2 (3)	0.4 (0.6)
C3	(10)	(10)	2.2 (3)	0.4 (0.6)
C4	10.3 (14) <sup>1)</sup> / 17.7 (24) <sup>2)</sup>	10.3 (14) <sup>1)</sup> / 17.7 (24) <sup>2)</sup>	2.2 (3)	0.4 (0.6)
D1h	14 (19)	14 (19)	14.0 (19)	0.4 (0.6)
D2h	14 (19)	14 (19)	14.0 (19)	0.4 (0.6)

<sup>1)</sup> Conductor cross-section  $\leq 95 \text{ mm}^2$ .

<sup>2)</sup> Conductor cross-section  $\geq 95 \text{ mm}^2$ .

## Cables

### Cable length

Maximum length, screened motor cable	500 ft (150 m)
Maximum length, unscreened motor cable	1000 ft (300 m)
Maximum length, signal cable	1000 ft (300 m)

### Cable cross-section to signal terminals

Maximum cable cross-section to signal terminals, rigid conductor	16 AWG (1.5 mm <sup>2</sup> )
Maximum cable cross-section to signal terminals, flexible conductor	18 AWG (1.0 mm <sup>2</sup> )
Minimum cable cross-section to signal terminals	22 AWG (0.5 mm <sup>2</sup> )

**Note:** For cable cross-section to power supply and motor, see section [Fuses](#), page 54.

## Inputs and outputs

### Power supply (L1, L2, L3)

Supply voltage	200-240 V ± 10 %
Supply voltage	380-500 V ± 10 %
Supply voltage	525-600 V ± 10 %
Supply voltage	525-690 V ± 10 %
Supply frequency	50/60 Hz
Maximum temporary imbalance between phases	3 % of rated value
Leakage current to ground	> 3.5 mA
Number of cut-ins, enclosure A	Max. 2 times/min.
Number of cut-ins, enclosures B and C	Max. 1 time/min.
Number of cut-ins, enclosure D	Max. 1 time/2 min.

**Note:** Do not use the supply voltage for switching the CUE on and off.

### Motor output (U, V, W)

Output voltage	0-100 % <sup>1)</sup>
Output frequency	0-100 Hz <sup>2)</sup>
Switching on output	Not recommended

<sup>1)</sup> Output voltage in % of supply voltage.

<sup>2)</sup> Depending on the pump family selected.

### RS-485 GENiBus connection

Terminal number	68 (A), 69 (B), 61 GND (Y)
-----------------	----------------------------

The RS-485 circuit is functionally separated from other central circuits and galvanically separated from the supply voltage (PELV).

### Digital inputs

Terminal number	18, 19, 32, 33
Voltage level	0-24 VDC
Voltage level, open contact	> 19 VDC
Voltage level, closed contact	< 14 VDC
Maximum voltage on input	28 VDC
Input resistance, R <sub>i</sub>	Approx. 4 kΩ

All digital inputs are galvanically separated from the supply voltage (PELV) and other high-voltage terminals.

### Signal relays

Relay 01, terminal number	1 (C), 2 (NO), 3 (NC)
Relay 02, terminal number	4 (C), 5 (NO), 6 (NC)
Maximum terminal load (AC-1) <sup>1)</sup>	240 VAC, 2 A
Maximum terminal load (AC-15) <sup>1)</sup>	240 VAC, 0.2 A
Maximum terminal load (DC-1) <sup>1)</sup>	50 VDC, 1 A
Minimum terminal load	24 VDC, 10 mA 24 VAC, 20 mA

<sup>1)</sup> IEC 60947, parts 4 and 5.

C: Common

NO: Normally open

NC: Normally closed

The relay contacts are galvanically separated from other circuits by reinforced insulation (PELV).

### Analog inputs

Analog input 1, terminal number (external setpoint)	53
Voltage signal	A53 = "U" <sup>1)</sup>
Voltage range	0-10 V
Input resistance	Approx. 10 kΩ
Maximum voltage	± 20 V
Current signal	A53 = "I" <sup>1)</sup>
Current range	0-20, 4-20 mA
Input resistance	Approx. 200 Ω
Maximum current	30 mA
Maximum fault, terminals 53, 54	0.5 % of full scale

Analog input 2, terminal number (sensor 1)	54
Current signal	A54 = "I" <sup>1)</sup>
Current range	0-20, 4-20 mA
Input resistance, R <sub>i</sub>	Approx. 200 Ω
Maximum current	30 mA
Maximum fault, terminals 53, 54	0.5 % of full scale

<sup>1)</sup> The factory setting is voltage signal "U".

All analog inputs are galvanically separated from the supply voltage (PELV) and other high-voltage terminals.

### Analog output

Analog output 1, terminal number (sensor 2)	42
Current range	0-20 mA
Maximum load to frame	500 Ω
Maximum fault	0.8 % of full scale

The analog output is galvanically separated from the supply voltage (PELV) and other high-voltage terminals.

### MCB 114 sensor input module

Analog input 3, terminal number	2
Current range	0/4-20 mA
Input resistance	< 200 Ω
Analog inputs 4, terminal number	4, 5
Analog inputs 5, terminal number	7, 8
Signal type, 2- or 3-wire	Pt100/Pt1000

**Note:** When using Pt100 with 3-wire cable, the resistance must not exceed 30 Ω.

## Fuses

Non-UL fuses and conductor cross-section to power supply and motor.

Typical shaft power P2	Maximum fuse size	Fuse type	Maximum conductor cross-section
[kW]	[A]		[AWG (mm <sup>2</sup> )]
<b>1 x 200-240 V</b>			
1.1	20	-	12 (4)
1.5	30	-	8 (10)
2.2	40	-	8 (10)
3	40	-	8 (10)
3.7	60	-	8 (10)
5.5	80	-	8 (10)
7.5	100	-	2 (35)
<b>3 x 200-240 V</b>			
0.75	10	gG	12 (4)
1.1	20	gG	12 (4)
1.5	20	gG	12 (4)
2.2	20	gG	12 (4)
3	32	gG	12 (4)
3.7	32	gG	12 (4)
5.5	63	gG	8 (10)
7.5	63	gG	8 (10)
11	63	gG	8 (10)
15	80	gG	2 (35)
18.5	125	gG	1 (50)
22	125	gG	1 (50)
30	160	gG	1 (50)
37	200	aR	3/0 (95)
45	250	aR	4/0 (120)
<b>3 x 380-500 V</b>			
0.55	10	gG	12 (4)
0.75	10	gG	12 (4)
1.1	10	gG	12 (4)
1.5	10	gG	12 (4)
2.2	20	gG	12 (4)
3	20	gG	12 (4)
4	20	gG	12 (4)
5.5	32	gG	12 (4)
7.5	32	gG	12 (4)
11	63	gG	8 (10)
15	63	gG	8 (10)
18.5	63	gG	8 (10)
22	63	gG	2 (35)
30	80	gG	2 (35)
37	100	gG	1 (50)
45	125	gG	1 (50)
55	160	gG	1 (50)
75	250	aR	3/0 (95)
90	250	aR	4/0 (120)
110	300	gG	2 x 70
132	350	gG	2 x 70
160	400	gG	2 x 185
200	500	gG	2 x 185
250	600	gR	2 x 185

Typical shaft power P2	Maximum fuse size	Fuse type	Maximum conductor cross-section
[kW]	[A]		[AWG (mm <sup>2</sup> )]
<b>3 x 525-600 V</b>			
0.75	10	gG	12 (4)
1.1	10	gG	12 (4)
1.5	10	gG	12 (4)
2.2	20	gG	12 (4)
3	20	gG	12 (4)
4	20	gG	12 (4)
5.5	32	gG	12 (4)
7.5	32	gG	12 (4)
<b>3 x 525-690 V</b>			
11	-	-	-
15	-	-	-
18.5	-	-	-
22	-	-	-
30	-	-	-
37	-	-	-
45	-	-	-
55	-	-	-
75	-	-	-
90	-	-	-
110	225	-	2 x 70
132	250	-	2 x 70
160	350	-	2 x 185
200	400	-	2 x 185
250	500	-	2 x 185

1) Screened motor cable, unscreened supply cable.

## UL fuses and conductor cross-section to power supply and motor

Typical shaft power P2 [kW]	Fuse type							Maximum conductor cross-section <sup>1)</sup> [AWG] <sup>2)</sup>
	Bussmann J	Bussmann T	SIBA RK1	Littel Fuse RK1	Ferraz-Shawmut CC	Ferraz-Shawmut RK1	Bussmann E1958 JFHR2	
<b>1 x 200-240 V</b>								
1.1	KTN-R20	-	-	-	-	-	-	10
1.5	KTN-R30	-	-	-	-	-	-	7
2.2	KTN-R40	-	-	-	-	-	-	7
3	KTN-R40	-	-	-	-	-	-	7
3.7	KTN-R60	-	-	-	-	-	-	7
5.5	-	-	-	-	-	-	-	7
7.5	-	-	-	-	-	-	-	2
<b>3 x 200-240 V</b>								
0.75	KTN-R10	JKS-10	JJN-10	5017906-010	KTN-R10	ATM-R10	A2K-10R	10
1.1	KTN-R20	JKS-20	JJN-20	5017906-020	KTN-R20	ATM-R20	A2K-20R	10
1.5	KTN-R20	JKS-20	JJN-20	5017906-020	KTN-R20	ATM-R20	A2K-20R	10
2.2	KTN-R20	JKS-20	JJN-20	5017906-020	KTN-R20	ATM-R20	A2K-20R	10
3	KTN-R30	JKS-30	JJN-30	5012406-032	KTN-R30	ATM-R30	A2K-30R	10
3.7	KTN-R30	JKS-30	JJN-30	5012406-032	KTN-R30	ATM-R30	A2K-30R	10
5.5	KTN-R50	JKS-50	JJN-50	5012406-050	KLN-R50	-	A2K-50R	7
7.5	KTN-R50	JKS-60	JJN-60	5012406-050	KLN-R60	-	A2K-50R	7
11	KTN-R60	JKS-60	JJN-60	5014006-063	KLN-R60	A2K-60R	A2K-60R	7
15	KTN-R80	JKS-80	JJN-80	5014006-080	KLN-R80	A2K-80R	A2K-80R	2
18.5	KTN-R125	JKS-150	JJN-125	2028220-125	KLN-R125	A2K-125R	A2K-125R	1/0
22	KTN-R125	JKS-150	JJN-125	2028220-125	KLN-R125	A2K-125R	A2K-125R	1/0
30	FWX-150	-	-	2028220-150	L25S-150	A25X-150	A25X-150	1/0
37	FWX-200	-	-	2028220-200	L25S-200	A25X-200	A25X-200	4/0
45	FWX-250	-	-	2028220-250	L25S-250	A25X-250	A25X-250	250 MCM
<b>3 x 380-500 V</b>								
0.55	KTS-R10	JKS-10	JJS-10	5017906-010	KTN-R10	ATM-R10	A2K-10R	10
0.75	KTS-R10	JKS-10	JJS-10	5017906-010	KTN-R10	ATM-R10	A2K-10R	10
1.1	KTS-R10	JKS-10	JJS-10	5017906-010	KTN-R10	ATM-R10	A2K-10R	10
1.5	KTS-R10	JKS-10	JJS-10	5017906-010	KTN-R10	ATM-R10	A2K-10R	10
2.2	KTS-R20	JKS-20	JJS-20	5017906-020	KTN-R20	ATM-R20	A2K-20R	10
3	KTS-R20	JKS-20	JJS-20	5017906-020	KTN-R20	ATM-R20	A2K-20R	10
4	KTS-R20	JKS-20	JJS-20	5017906-020	KTN-R20	ATM-R20	A2K-20R	10
5.5	KTS-R30	JKS-30	JJS-30	5012406-032	KTN-R30	ATM-R30	A2K-30R	10
7.5	KTS-R30	JKS-30	JJS-30	5012406-032	KTN-R30	ATM-R30	A2K-30R	10
11	KTS-R40	JKS-40	JJS-40	5014006-040	KLS-R40	-	A6K-40R	7
15	KTS-R40	JKS-40	JJS-40	5014006-040	KLS-R40	-	A6K-40R	7
18.5	KTS-R50	JKS-50	JJS-50	5014006-050	KLS-R50	-	A6K-50R	7
22	KTS-R60	JKS-60	JJS-60	5014006-063	KLS-R60	-	A6K-60R	2
30	KTS-R80	JKS-80	JJS-80	2028220-100	KLS-R80	-	A6K-80R	2
37	KTS-R100	JKS-100	JJS-100	2028220-125	KLS-R100	-	A6K-100R	1/0
45	KTS-R125	JKS-150	JJS-150	2028220-125	KLS-R125	-	A6K-125R	1/0
55	KTS-R150	JKS-150	JJS-150	2028220-160	KLS-R150	-	A6K-150R	1/0
75	FWH-220	-	-	2028220-200	L50S-225	-	A50-P225	4/0
90	FWH-250	-	-	2028220-250	L50S-250	-	A50-P250	250 MCM
110	FWH-300	JJS-300	NOS-300	170M3017	2028220-315	L50S-300	A50-P300	2 x 2/0
132	FWH-350	JJS-350	NOS-350	170M3018	2028220-315	L50S-350	A50-P350	2 x 2/0
160	FWH-400	JJS-400	NOS-400	170M4012	206xx32-400	L50S-400	A50-P400	2 x 350 MCM
200	FWH-500	JJS-500	NOS-500	170M4014	206xx32-500	L50S-500	A50-P500	2 x 350 MCM
250	FWH-600	JJS-600	NOS-600	170M4016	206xx32-600	L50S-600	A50-P600	2 x 350 MCM
-	-	-	-	Bussmann E125085 JFHR2	SIBA E180276 JFHR2	-	Ferraz-Shawmut E76491 JFHR2	-
<b>3 x 525-600 V</b>								
0.75	KTS-R10	JKS-10	JJS-10	5017906-010	KTN-R10	ATM-R10	A2K-10R	10
1.1	KTS-R10	JKS-10	JJS-10	5017906-010	KTN-R10	ATM-R10	A2K-10R	10
1.5	KTS-R10	JKS-10	JJS-10	5017906-010	KTN-R10	ATM-R10	A2K-10R	10
2.2	KTS-R20	JKS-20	JJS-20	5017906-020	KTN-R20	ATM-R20	A2K-20R	10
3	KTS-R20	JKS-20	JJS-20	5017906-020	KTN-R20	ATM-R20	A2K-20R	10
4	KTS-R20	JKS-20	JJS-20	5017906-020	KTN-R20	ATM-R20	A2K-20R	10
5.5	KTS-R30	JKS-30	JJS-30	5012406-032	KTN-R30	ATM-R30	A2K-30R	10
7.5	KTS-R30	JKS-30	JJS-30	5012406-032	KTN-R30	ATM-R30	A2K-30R	10

Typical shaft power P2 [kW]	Fuse type							Maximum conductor cross-section <sup>1)</sup> [AWG] <sup>2)</sup>
	Bussmann J	Bussmann T	SIBA RK1	Littel Fuse RK1	Ferraz- Shawmut CC	Ferraz- Shawmut RK1	Bussmann E1958 JFHR2	
3 x 525-690 V								
11	KTS-R-25	JKS-25	JJS-25	5017906-025	KLSR025	HST25	A6K-25R	1/0
15	KTS-R-30	JKS-30	JJS-30	5017906-030	KLSR030	HST30	A6K-30R	1/0
18.5	KTS-R-45	JKS-45	JJS-45	5014006-050	KLSR045	HST45	A6K-45R	1/0
22	KTS-R-45	JKS-45	JJS-45	5014006-050	KLSR045	HST45	A6K-45R	1/0
30	KTS-R-60	JKS-60	JJS-60	5014006-063	KLSR060	HST60	A6K-60R	1/0
37	KTS-R-80	JKS-80	JJS-80	5014006-080	KLSR075	HST80	A6K-80R	1/0
45	KTS-R-90	JKS-90	JJS-90	5014006-100	KLSR090	HST90	A6K-90R	1/0
55	KTS-R-100	JKS-100	JJS-100	5014006-100	KLSR100	HST100	A6K-100R	1/0
75	KTS-R125	JKS-125	JJS-125	2028220-125	KLS-125	HST125	A6K-125R	1/0
90	KTS-R150	JKS-150	JJS-150	2028220-150	KLS-150	HST150	A6K-150R	1/0
110	-	-	-	170M3017	2061032.315	-	6.6URD30D08 A0315	2 x 2/0
132	-	-	-	170M3018	2061032.350	-	6.6URD30D08 A0350	2 x 2/0
160	-	-	-	170M4011	2061032.350	-	6.6URD30D08 A0350	2 x 2/0
200	-	-	-	170M4012	2061032.400	-	6.6URD30D08 A0400	2 x 350 MCM
250	-	-	-	170M4014	2061032.500	-	6.6URD30D08 A0500	2 x 350 MCM

1) Screened motor cable, unscreened supply cable.

2) American Wire Gauge.



## Pump-family parameters

Pump family	Motor bearing monitoring*	Dry-running restart time-out [sec]	Final ramp time [sec]	Initial ramp time [sec]	Flow test, max. frequency [% of nominal frequency]	Flow test, max. frequency [% of nominal frequency]	Speed, sensor lost in constant pressure [% of nominal frequency]
AFG	TRUE	1.5	300	5	5	100	100
AMD	TRUE	1.5	300	5	5	100	100
AMG	TRUE	1.5	300	5	5	100	100
BM, BMB	FALSE		5	1	1	100	0
BME, BMET, BMEX	TRUE	30	5	1	1	100	0
BMP	FALSE		5	1	1	100	0
CH, CHI, CHN, CHV	FALSE		5	1	1	100	100
CHIU	FALSE		5	1	1	100	100
CM	FALSE		5	1	1	90	70
CMV							
Contra	TRUE	11	5	1	1	100	100
CPH, CPV	FALSE		5	1	1	100	70
CR, CRI, CRN, CRT	TRUE	7.5	5	3	1	90	70
CRK	TRUE	7.5	5	3	1	100	70
CV	TRUE	7.5	5	3	1	100	70
DP, EF	TRUE	4	300	5	5	100	100
Durietta	TRUE	11	5	1	1	100	100
Euro HYGIA	TRUE	11	5	1	1	100	100
F&B HYGIA	TRUE	11	5	1	1	100	100
HS	FALSE		5	1	1	100	70
LC,LF	FALSE		5	1	1	100	70
MAXA, MAXANA	TRUE	11	5	1	1	100	100
MTA, MTH, MTR	TRUE	7.5	5	3	1	100	70
MTB	TRUE	7.5	5	3	1	100	70
NB, NK	TRUE	11	5	3	1	100	70
NBG, NKG	TRUE	11	5	3	1	100	70
RC	FALSE		10	3	1	100	100
S	TRUE	4	300	5	5	100	100
SE, SEN, SEV	TRUE	4	300	5	5	100	100
SP, SP-G, SP-NE	FALSE		480	3	3	100	0
SPK	TRUE	7.5	5	3	1	100	70
SRP	TRUE	1.5	300	5	5	100	100
TP	TRUE	11	5	3	1	100	70
VL	FALSE		5	1	1	100	70
Other pumps	TRUE	7.5	5	3	1	100	70

\* TRUE: Possible.  
FALSE: Not possible.

Pump family	Lower frequency [Hz]	Manual rotation check frequency [% of nominal frequency]	Maximum permissible frequency/nominal frequency factor [% of nominal frequency]	Minimum frequency [% of nominal frequency]	PID start speed [rpm]	Torque characteristics**
AFG	30	0	100	50	1450	1
AMD	30	0	100	50	1450	1
AMG	30	0	100	50	1450	1
BM, BMB	30	100	100	50	1450	1
BME, BMET, BMEX	30	0	100	50	1450	1
BMP	25	0	120	50	1450	0
CH, CHI, CHN, CHV	6	0	111	24	700	1
CHIU	12	100	200	24	700	1
CM	6	0	100	25	700	1
CMV						
Contra	6	0	100	24	700	1
CPH, CPV	6	0	150	0	700	1
CR, CRI, CRN, CRT	6	0	150	25	725	1
CRK	6	0	150	25	725	1
CV	6	0	150	25	725	1
DP, EF	30	50	100	50	1450	1
Durietta	6	0	100	24	700	1
Euro HYGIA	6	0	100	24	700	1
F&B HYGIA	6	0	100	24	700	1
HS	6	0	120	0	700	1
LC,LF	6	0	100	0	700	1
MAXA, MAXANA	6	0	100	24	700	1
MTA, MTH, MTR	6	0	150	25	725	1
MTB	6	0	150	25	725	1
NB, NK	6	0	100	25	725	1
NBG, NKG	6	0	100	25	725	1
RC	25	80	100	50	2500	1
S	30	100	100	50	1450	1
SE, SEN, SEV	30	50	100	50	1450	1
SP, SP-G, SP-NE	30	100	100	50	1450	1
SPK	6	0	150	25	725	1
SRP	30	0	120	50	1450	1
TP	6	0	150	25	725	1
VL	6	0	100	25	700	1
Other pumps	6	0	100	25	725	1

\*\* 1: Variable torque.  
0: Constant torque.

# 11. Accessories

## Product numbers

### CUE accessories

Connectors, see page 61	Type	Product number
Connectors for CUE (spare parts)	All types	97641449
Add-on module, see page 60	Type	Product number
Sensor input module	MCB 114	96760901
Control panel, see page 61		
Grundfos Local Control Panel	GLCP	96809398
Remote-mounting option for GLCP, with 9.8 ft (3 m) cable	GLCP remote mounting	96801229
Floor-mounting option, see page 62		
Enclosures D1 and D2, option including pedestal parts and instructions	Floor mounting	96801230
Enclosures D1h option including pedestal parts	Floor mounting	96806900
Enclosures D2h option including pedestal parts	Floor mounting	96806903
IP21/NEMA1 option, see page 63		
Enclosure A2	IP21/NEMA1 A2	96801223
Enclosure A3	IP21/NEMA1 A3	96801224
Enclosure B3	IP21/NEMA1 B3	96801225
Enclosure B4	IP21/NEMA1 B4	96801226
Enclosure C3	IP21/NEMA1 C3	96801227
Enclosure C4	IP21/NEMA1 C4	96801228
Output filters, see page 66		
Sine-wave filters		1)
dU/dt filters		1)

1) Product numbers for sine-wave filters and dU/dt filters, see pages 44 to 49.

### Communication modules

Communication interface	Type	Product number
LonWorks gateway	CIU 100	96753735
Lon MPC	CIU 110	96753736
PROFIBUS gateway	CIU 150	96753081
Modbus gateway	CIU 200	96753082
GSM modem	CIU 250	96787106
BACnet communication interface	CIU 300	96893769
Grundfos Remote Management (GRM)	CIU 271	96898819
Modbus TCP	CIU 500	96753894

## MCB 114 sensor input module



Fig. 55 MCB 114 sensor input module

TM04 0293 0308

The MCB 114 offers three additional analog inputs for the CUE:

- one analog 0/4-20 mA input for an additional sensor
- two analog Pt100/Pt1000 inputs for temperature sensors.

The three analog inputs are used by default for monitoring. For further information, see [MCB 114 sensor input module](#), page 32.

### Scope of delivery

The MCB 114 comes with a terminal cover, an extended frame and an identification label to put onto the CUE.

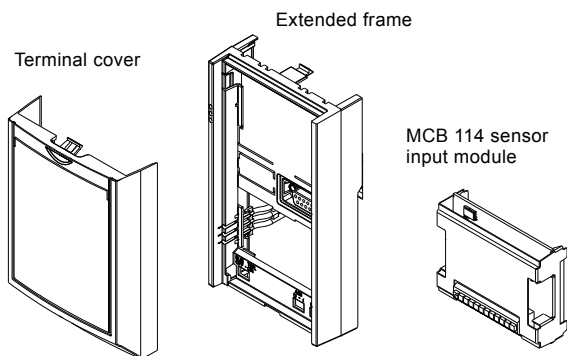

Fig. 56 Scope of delivery

TM04 0026 4807

### Technical data

Relative humidity	5-95 % RH
Ambient temperature during operation	14 to 131 °F (-10 to 55 °C)
Temperature during storage and transportation	-13 to 158 °F (-25 to 70 °C)
Maximum length, signal cable	984 ft (300 m)
<b>Analog input 3</b>	
Terminal number	2
Current range	0/4-20 mA
Input resistance	< 200 Ω
<b>Analog inputs 4 and 5</b>	
Terminal number	4, 5 and 7, 8
Signal type, 2- or 3-wire	Pt100/Pt1000

All analog inputs are galvanically separated from the supply voltage (PELV) and other high-voltage terminals.

### Wiring diagram

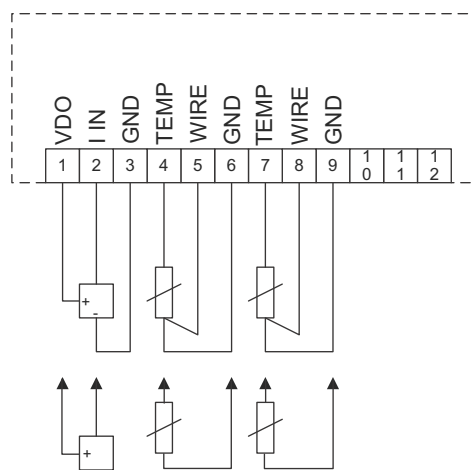

Fig. 57 Wiring diagram, MCB 114

TM04 3273 3908

Terminal	Type	Function
1	+24 V out	Supply to sensor
2	AI 3	Sensor 2, 0/4-20 mA
3	GND	Common frame for analog input
4, 5	AI 4	Temperature sensor 1, Pt100/Pt1000
6	GND	Common frame for temperature sensor 1
7, 8	AI 5	Temperature sensor 2, Pt100/Pt1000
9	GND	Common frame for temperature sensor 2

Terminals 10, 11 and 12 are not used.

### Connectors

This accessory comprises all connectors required for the CUE such as power supply connector, motor connector and relay connectors. Only one accessory contains connectors for all CUE sizes.

Connectors are not available separately.

### Grundfos Local Control Panel, GLCP

GLCP is used for local setting of the CUE.

The CUE unit comes with a GLCP fitted by default, but the control panel is also available as an option.

Cable is not included.

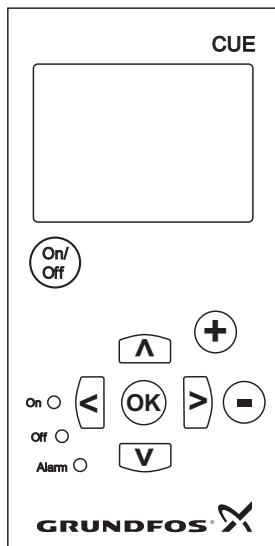

Fig. 58 Control panel of the CUE

For further information, see the installation and operating instructions of the CUE.

### Remote-mounting option for GLCP

By means of a remote-mounting option, the GLCP can also be moved to the front of a cabinet. The enclosure is IP65. The fastening screws must be tightened to a torque of maximum 1.36 ft-lb (1 Nm).

The remote-mounting option includes fasteners, 9.8 ft (3 m) cable and gasket.

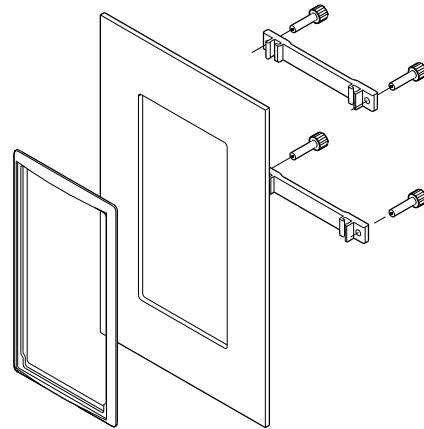

TM04 0376 0608

Fig. 59 Remote-mounting option for GLCP

### Dimensions

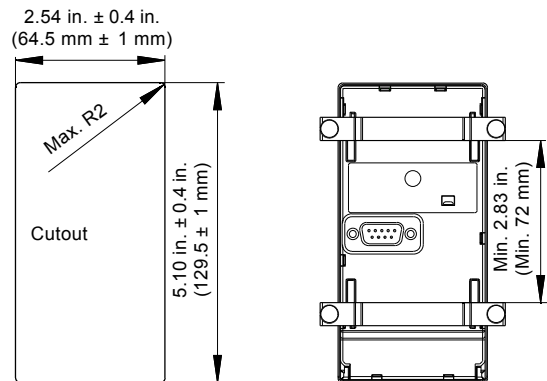

TM03 8719 2507

TM04 0377 0608

Fig. 60 Cabinet mounting, dimensions of cutout

For further information, see the installation and operating instructions of the remote-mounting option.

## Floor-mounting option

By means of a pedestal, the CUE can also be mounted on the floor. A pedestal has been designed for that purpose.

One pedestal fits both enclosure D1h and D2h.

### Scope of delivery

- Primary pedestal frame
- vented front cover
- two side covers
- two front brackets
- hardware for assembly
- instructions.

### Drilling dimensions

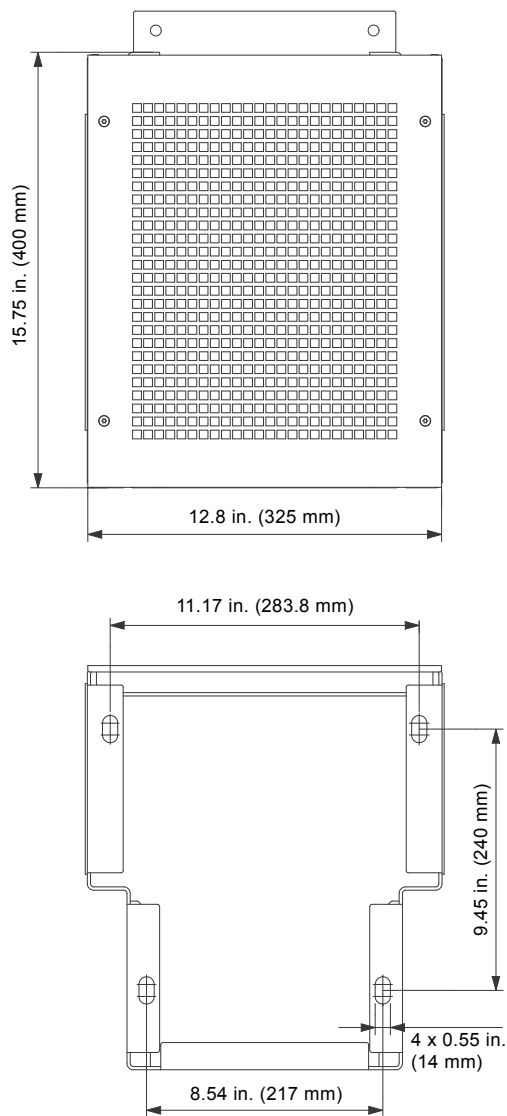

Fig. 61 Drilling template for pedestal [in. (mm)]



TM03 9895 4607

Fig. 62 CUE enclosure D1h or D2h on a pedestal

Please see the instructions of the pedestal option for further information.

TM05 9669 4313

## IP21/NEMA1 option

An IP20 enclosure can be upgraded to IP21/NEMA1 with the IP20/NEMA1 option. If this option is used, the power terminals (power supply and motor) will be covered. See fig. 63.

The IP21/NEMA1 option is available for the enclosures A2, A3, B3, B4, C3 and C4.

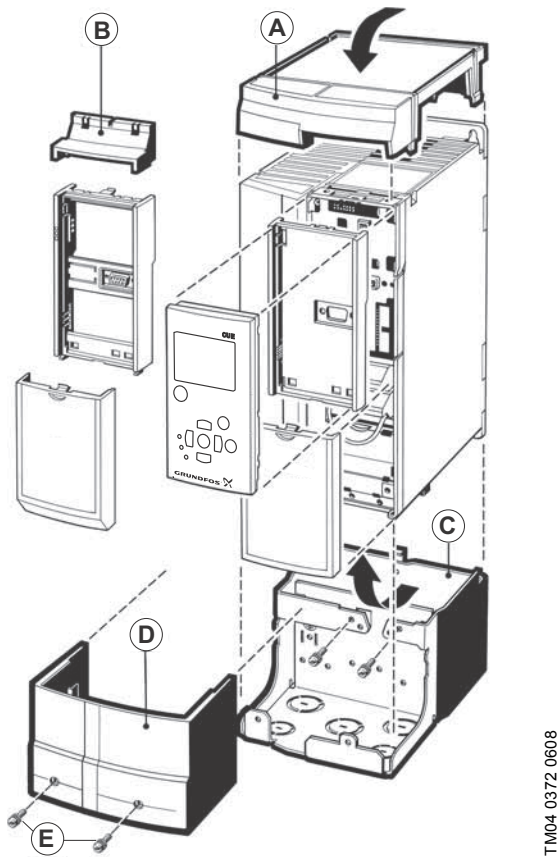

**Fig. 63** Example of IP21/NEMA1 option for enclosure A3

### Scope of delivery

- A: Top cover
- B: Brim
- C: Base part
- D: Base cover
- E: Screw(s).

If the MCB 114 sensor input module is fitted, the brim (B) must be fitted on the top cover (A).

## Sensors, SI units

Danfoss pressure sensor, cable not included	Type	Measuring range [psi (bar)]	Product number
Pressure connection: G 1/2" A (DIN 16288 - B6kt) Electrical connection: Plug (DIN 43650)	MBS 3000	0-36 (0 - 2.5)	96478188
	MBS 3000	0-58 (0-4)	91072075
	MBS 3000	0-87 (0-6)	91072076
	MBS 3000	0-145 (0-10)	91072077
	MBS 3000	0-232 (0-16)	91072078
MBS 3000	0-362 (0-25)	91072079	
<b>Danfoss pressure sensor option, 6.5 ft (2 m) screened cable</b>			
Pressure connection: G 1/2" A (DIN 16288 - B6kt) 5 cable clips (black) Instruction manual PT (00 40 02 12)	MBS 3000	0-58 (0-4)	96428014
	MBS 3000	0-87 (0-6)	96428015
	MBS 3000	0-145 (0-10)	96428016
	MBS 3000	0-232 (0-16)	96428017
	MBS 3000	0-362 (0-25)	96428018
Pressure connection: G 1/4" A (DIN 16288 - B6kt) 5 cable clips (black) Instruction manual PT (00 40 02 12)	MBS 3000	0-36 (0-2.5)	405159
	MBS 3000	0-58 (0-4)	405160
	MBS 3000	0-87 (0-6)	405161
	MBS 3000	0-145 (0-10)	405162
	MBS 3000	0-232 (0-16)	405163
<b>Grundfos differential pressure sensor option, 3 ft (0.9 m) screened cable</b>			
Pressure connection: 7/16" Including fittings for pressure connection (1/4" - 7/16") Brackets for wall and motor mounting 3 capillary tubes (short/long) and 5 cable clips (black) Installation and operating instructions Service kit instructions	DPI	0 - 8.7 (0 - 0.6)	96611522
	DPI	0 - 14.5 (0 - 1.0)	96611523
	DPI	0-23 (0 - 1.6)	96611524
	DPI	0-36 (0 - 2.5)	96611525
	DPI	0-58 (0-4)	96611526
	DPI	0-87 (0-6)	96611527
	DPI	0-145 (0-10)	96611550
<b>Carlo Gavazzi temperature sensor</b>			
<b>[°F (°C)]</b>			
Temperature sensors	TTA (0) 25	0 - +77 (0 - +25)	96432591
	TTA (-25) 25	-13 - 77 (-25 - +25)	96430194
	TTA (50) 100	122-212 (50-100)	96432592
	TTA (0) 150	0-302 (0-150)	96430195
Sensor pocket for TTA, with G 1/2" connection	∅9 mm x 50 mm	-	96430201
	∅9 mm x 100 mm	-	96430202
Cutting ring bush for TTA, with G 1/2" connection	-	-	96430203
<b>Siemens flowmeter</b>			
<b>[gal./min. (m<sup>3</sup>/h)]</b>			
Siemens flowmeter, MAGFLO	MAG 3100/5000	4.4 - 22 (1-5 (DN 25))	00ID8285
	MAG 3100/5000	13.2 - 44 (3-10 (DN 40))	00ID8286
	MAG 3100/5000	26.4 - 132 (6-30 (DN 65))	00ID8287
	MAG 3100/5000	88-330 (20-75 (DN 100))	00ID8288
<b>Siemens analog level sensor</b>			
<b>[psi (bar)]</b>			
Analog level sensor with cable hanger	-	0 - 7.25 (0.5)	96377410
Ultrasonic transmitter for level	-	0 - 7.25 (0.5)	96693767
<b>Jumo level sensor</b>			
With 32 ft (10 m) cable	4390	0 - 1.45 (0 - 0.1)	96457344
With 65 ft (20 m) cable	4390	0 - 1.45 (0 - 0.1)	96457345
With 98 ft (30 m) cable	4390	0 - 14.5 (0 - 1.0)	96457341
With 246 ft (75 m) cable	4390	0 - 14.5 (0 - 1.0)	96457342
With 393 ft (120 m) cable	4390	0 - 14.5 (0 - 1.0)	96457343
With 98 ft (30 m) cable	4390	0-36 (0 - 2.5)	96457489
With 213 ft (65 m) cable	4390	0-87 (0-6)	96457490
With 344 ft (105 m) cable	4390	0-145 (0-10)	96457491

**Note:** All sensors have a 4-20 mA output.



## Sensors, US units

Danfoss pressure sensor, cable not included	Type	Measuring range [psi (bar)]	Product number
Pressure connection: 1/4" - 18 NPT Electrical connection: DIN 43650 (plug not included)	MBS 3000	0-58 (0-4)	91136013
	MBS 3000	0-87 (0-6)	91136014
	MBS 3000	0-145 (0-10)	91136015
	MBS 3000	0-232 (0-16)	91136016
	MBS 3000	0-362 (0-25)	91136017
	MBS 3000	0-580 (0-40)	91136018
	MBS 3000	0-870 (0-60)	91136019
Danfoss pressure sensor, 6.5 ft (2 m) screened cable			
Pressure connection: 1/2" - 14 NPT	MBS 3000	0-120 (0-8)	96437852
Grundfos differential pressure sensor, 3 ft (0.9 m) screened cable			
Pressure connection: 7/16" flare		[ft (m)]	
	DPI	0-20 (0-6)	96624396
	DPI	0-33 (0-10)	96624397
	DPI	0-54 (0-16)	96624398
	DPI	0-84 (0-25)	96624399
	DPI	0-200 (0-60)	96624441
	DPI	0-334 (0-101)	96624442

**Note:** All sensors have a 4-20 mA output.

## Pt100 temperature sensors

Pt100 temperature sensor	Type	Measuring range	Product number
With 65 ft (20 m) cable	-	-	96408957
With 131 ft (40 m) cable	-	-	96408684
With 196 ft (60 m) cable	-	-	96408958
With 262 ft (80 m) cable	-	-	96408959
With 328 ft (100 m) cable	-	-	96408960
With 65 ft (20 m) cable	-	-	96437784
With 131 ft (40 m) cable	-	-	96437785
With 196 ft (60 m) cable	-	-	96437786
With 262 ft (80 m) cable	-	-	96437787
With 328 ft (100 m) cable	-	-	96437788
Pt100 temperature sensor and cable extension			
Pt100	-	-	95043173
Cable extension <sup>1)</sup>	-	-	00RM5271
Cable extension, unassembled option <sup>1)</sup>	-	-	96571480
Cable extension, assembled option <sup>1)</sup>	-	-	96763223

<sup>1)</sup> State length when ordering.

## Other accessories

Dry-running protection <sup>1)</sup>	Type	Product number
Module, sensor, 16 ft (5 m) cable, 200-240 V <sup>2)</sup>	LiqTec	96443674
Module, sensor, 16 ft (5 m) cable, 80-130 V <sup>2)</sup>	LiqTec	96443912
Extension cable, 49 ft (15 m)		96443676

<sup>1)</sup> Main pump types CR, CRI, CRN, MTR, SPK, CRK and CHI.

<sup>2)</sup> Sensor connection: 1/2".

## Output filters

Grundfos offers two types of output filter as accessories for the CUE:

- dU/dt filters
- sine-wave filters

The filters are in IP20/NEMA1 enclosure.



Fig. 64 Wall-mounted sine-wave filters

## Use of output filters

The table shows if a filter is needed and which type to use.

Pump type	Typical shaft power P <sub>2</sub>	dU/dt filter	Sine-wave filter
SP, BM, BMB with 380 V motor and up	Up to 10 Hp (7.5 kW)	-	0-984 ft (0-300 m)
	15 Hp (11 kW) and up	0-492 ft (0-150 m)	492-984 ft (150-300 m)
Other pumps, noise reduction	Up to 10 Hp (7.5 kW)	-	0-984 ft (0-300 m)
	15 Hp (11 kW) and up	0-492 ft (0-150 m)	492-984 ft (150-300 m)
Other pumps, higher noise reduction	Up to 10 Hp (7.5 kW)	-	0-984 ft (0-300 m)
	15 Hp (11 kW) and up	-	0-984 ft (0-300 m)
Pumps with 690 V motor	All	0-492 ft (0-150 m)	492-984 ft (150-300 m)

The lengths stated apply to the motor cable.

For information about installation, see page 38.

Dimensions and weight of output filters

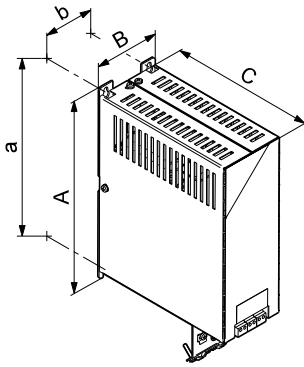
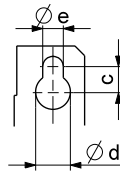
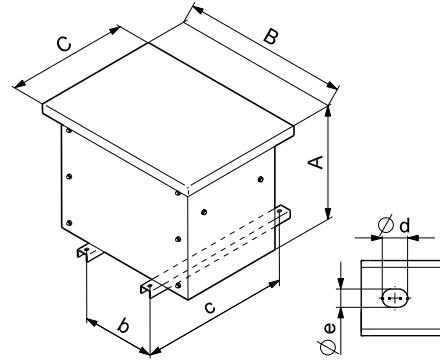

Fig. 65 Wall mounting



TM04 0625 0908



TM04 0624 0908

Fig. 66 Floor mounting

Product number	Mounting	Height [in. (mm)]		Width [in. (mm)]		Depth [in. (mm)]		Screw holes [in. (mm)]			Weight [lb (kg)]
		A	a	B	b	C	c	Ød	Øe	f	
<b>Sine-wave filters</b>											
96754941	Wall	7.87 (200)	7.48 (190)	2.95 (75)	2.36 (60)	8.07 (205)	-	.315 (8)	.177 (4.5)	.276 (7)	7.3 (3.3)
96754972	Wall	7.87 (200)	7.48 (190)	2.95 (75)	2.36 (60)	8.07 (205)	-	.315 (8)	.177 (4.5)	.276 (7)	9.3 (4.2)
96754973	Wall	10.55 (268)	10.12 (257)	3.54 (90)	2.76 (70)	8.11 (206)	-	.433 (11)	.256 (6.5)	.315 (8)	101.0 (5.8)
96754974	Wall	10.55 (268)	10.12 (257)	3.54 (90)	2.76 (70)	8.07 (205)	-	.433 (11)	.256 (6.5)	.315 (8)	103.9 (7.1)
96754976	Wall	10.55 (268)	10.12 (257)	5.12 (130)	3.54 (90)	8.07 (205)	-	.433 (11)	.256 (6.5)	.315 (8)	20.1 (9.1)
96754977	Wall	12.99 (330)	12.28 (312)	5.90 (150)	4.72 (120)	10.24 (260)	-	.748 (19)	.354 (9)	.472 (12)	37.3 (16.9)
96754978	Wall	16.93 (430)	16.22 (412)	5.90 (150)	4.72 (120)	10.24 (260)	-	.748 (19)	.354 (9)	.472 (12)	43.9 (19.9)
96755019	Wall	20.87 (530)	19.69 (500)	6.69 (170)	4.92 (125)	10.24 (260)	-	.748 (19)	.354 (9)	.472 (12)	86.0 (39)
96755021	Wall	24.02 (610)	22.83 (580)	6.69 (170)	4.92 (125)	10.24 (260)	-	.748 (19)	.354 (9)	.472 (12)	90.4 (41)
96755032	Wall	24.02 (610)	22.83 (580)	6.69 (170)	5.32 (135)	10.24 (260)	-	.748 (19)	.354 (9)	.472 (12)	119.0 (54)
96755033	Floor	20.55 (522)	-	26.38 (670)	11.42 (290)	19.69 (500)	18.11 (460)	.591 (15)	.433 (11)	-	191.8 (87)
96755034	Floor	30.79 (782)	-	37.01 (940)	15.74 (400)	25.60 (650)	24.02 (610)	.591 (15)	.433 (11)	-	249.1 (113)
96755037	Floor	30.79 (782)	-	37.01 (940)	15.74 (400)	25.60 (650)	24.02 (610)	.591 (15)	.433 (11)	-	418.9 (190)
96755038	Floor	30.79 (782)	-	37.01 (940)	16.93 (430)	25.60 (650)	24.02 (610)	.591 (15)	.433 (11)	-	540.1 (245)
96755039	Floor	29.21 (742)	-	4.39 (1050)	16.93 (430)	29.92 (760)	28.32 (720)	.591 (15)	.433 (11)	-	683.4 (310)
96755040	Wall	16.93 (430)	16.22 (412)	5.90 (150)	4.72 (120)	10.24 (260)	-	.748 (19)	.354 (9)	.472 (12)	36.8 (16.7)
96755041	Floor	20.55 (522)	-	26.38 (670)	8.66 (220)	19.69 (500)	18.11 (460)	.591 (15)	.433 (11)	-	121.3 (55)
96755042	Floor	20.55 (522)	-	26.38 (670)	10.24 (260)	19.69 (500)	18.11 (460)	.591 (15)	.433 (11)	-	154.3 (70)
96755043	Floor	20.55 (522)	-	26.38 (670)	12.20 (310)	19.69 (500)	18.11 (460)	.591 (15)	.433 (11)	-	231.5 (105)
96755044	Floor	20.55 (522)	-	25.20 (640)	14.96 (380)	19.69 (500)	18.11 (460)	.591 (15)	.433 (11)	-	330.7 (150)
96755045	Floor	30.79 (782)	-	35.83 (910)	16.93 (430)	25.60 (650)	24.02 (610)	.591 (15)	.433 (11)	-	485.0 (220)
96755047	Floor	30.79 (782)	-	37.01 (940)	19.69 (500)	25.60 (650)	24.02 (610)	.591 (15)	.433 (11)	-	628.3 (285)
96755049	Floor	43.35 (1152)	-	50.79 (1290)	19.29 (490)	31.50 (800)	29.92 (760)	.591 (15)	.433 (11)	-	815.7 (370)
96755050	Floor	43.35 (1152)	-	50.79 (1290)	21.26 (540)	31.50 (800)	29.92 (760)	-	-	-	1212.5 (550)
<b>dU/dt filters</b>											
96755062	Wall	10.55 (268)	10.12 (257)	4.72 (120)	3.54 (90)	8.07 (205)	-	.433 (11)	.256 (6.5)	.315 (8)	11.5 (5.2)
96755063	Wall	12.99 (330)	12.28 (312)	6.69 (170)	4.92 (125)	10.24 (260)	-	.748 (19)	.354 (9)	.472 (12)	20.5 (9.3)
96755064	Wall	12.99 (330)	12.28 (312)	6.69 (170)	4.92 (125)	10.24 (260)	-	.748 (19)	.354 (9)	.472 (12)	23.6 (10.7)
96755066	Wall	12.99 (330)	12.28 (312)	6.69 (170)	4.92 (125)	10.24 (260)	-	.748 (19)	.354 (9)	.472 (12)	28.2 (12.8)
96755067	Floor	18.19 (462)	-	24.02 (610)	6.89 (175)	17.32 (440)	15.74 (400)	.591 (15)	.433 (11)	-	72.8 (33)
96755069	Floor	18.23 (463)	-	24.02 (610)	7.48 (190)	17.32 (440)	15.74 (400)	.591 (15)	.433 (11)	-	110.2 (50)
96755070	Floor	22.48 (571)	-	30.31 (770)	7.48 (190)	21.56 (550)	20.08 (510)	.591 (15)	.433 (11)	-	132.3 (60)
96755071	Floor	20.55 (522)	-	26.38 (670)	8.47 (215)	19.69 (500)	18.11 (460)	.591 (15)	.433 (11)	-	127.9 (58)
96755078	Wall	-	11.81 (300)	5.91 (150)	4.72 (120)	10.24 (260)	-	.748 (19)	.354 (9)	.472 (12)	18.3 (8.3)
96755079	Wall	-	12.28 (312)	6.69 (170)	4.92 (125)	10.24 (260)	-	.748 (19)	.354 (9)	.472 (12)	20.7 (9.4)
96755080	Wall	12.99 (330)	12.28 (312)	6.69 (170)	4.92 (125)	10.24 (260)	-	.748 (19)	.354 (9)	.472 (12)	26.01 (11.8)
96755081	Wall	12.99 (330)	12.28 (312)	6.69 (170)	4.92 (125)	10.24 (260)	-	.748 (19)	.354 (9)	.472 (12)	26.9 (12.2)
96755082	Floor	20.55 (522)	-	26.38 (670)	8.47 (215)	19.69 (500)	18.11 (460)	.591 (15)	.433 (11)	-	99.2 (45)
96755083	Floor	20.55 (522)	-	25.20 (640)	8.47 (215)	19.69 (500)	18.11 (460)	.591 (15)	.433 (11)	-	103.6 (47)
96755084	Floor	20.55 (522)	-	26.38 (670)	8.47 (215)	19.69 (500)	18.11 (460)	.591 (15)	.433 (11)	-	103.6 (47)
96755085	Floor	20.55 (522)	-	26.38 (670)	8.47 (215)	19.69 (500)	18.11 (460)	.591 (15)	.433 (11)	-	114.6 (52)

## Grundfos differential pressure sensor, DPI

### Product description

A cable (pos. 1) goes through an M12 x 1.5 Pg connection. See fig. 67.

The sensor housing and parts in contact with the medium are made of Inox DIN W.-Nr. 1.4305 (pos. 3) with composite PA top (pos. 2). The pressure connections (pos. 4) are DIN W.-Nr. 1.4305, 7/16" UNF, and gaskets are FKM.

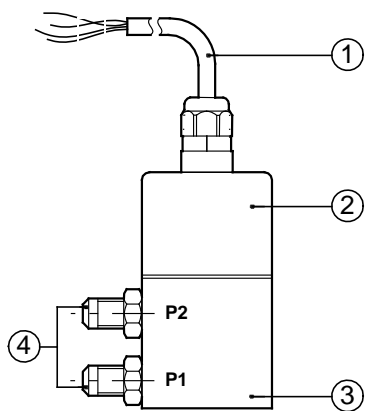

Fig. 67 DPI position numbers

The sensor is supplied with angular bracket for mounting on motor or bracket for wall mounting. See fig. 69.

Options with other cable lengths and various fitting connectors are available.

### Dimensions

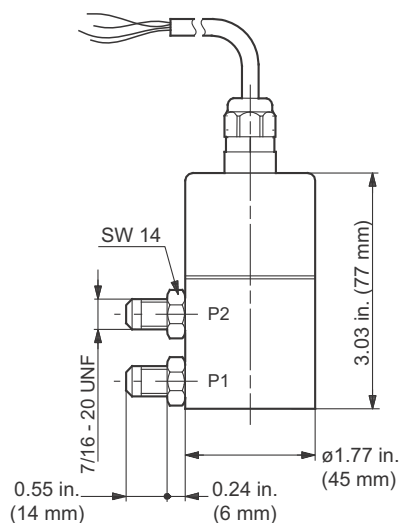

Fig. 68 Dimensions, DPI

### Wiring diagram

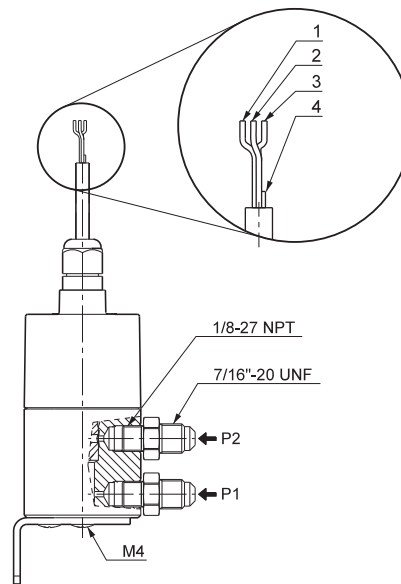

Fig. 69 Wiring diagram, DPI

No	Color	Function
1	Brown	Supply voltage, 12-30 V
2	Yellow	GND
3	Green	Control signal
4	White	Test signal. Must not be connected to supply voltage (conductor may be cut off)

### Technical data

Supply voltage	12-30 VDC
Output signal	4-20 mA
Load [ $\Omega$ ]	24 V: max. 500 [ $\Omega$ ] 16 V: max. 200 [ $\Omega$ ] 12 V: max. 100 [ $\Omega$ ]
Max. system pressure, P1 and P2 simultaneously	232 psi (16 bar)
Rupture pressure [bar]	1.5 x system pressure
Measuring accuracy	2.5 % BFSL
Response time	< 0.5 sec
Media temperature range	+14 °F to +158 °F (-10 °C to +70 °C)
Storage temperature range	-40 °F to 176 °F (-40 °C to +80 °C)
Electrical connection	3-wire 0.13 mm <sup>2</sup> 2.9 ft (0.9 m) cable M12 x 1.5 in sensor top
Short-circuit proof	Yes
Protected against reverse polarity	Yes
Over supply voltage	Yes
Materials in contact with medium	DIN W.-Nr. 1.4305 FKM and PPS
Enclosure class	IP55
Weight	550 g
EMC (electromagnetic compatibility)	According to EN 61326-1
Emission/immunity	According to EN 61326-1
Connections	7/16"-UNF
Sealing material	FKM

TM03 2057 3505

TM03 2225 3905

TM06 3680 0815

## Temperature sensor, TTA

### Product description

Temperature sensor with Pt100 resistance element mounted in a  $\varnothing 0.24 \times 3.94$  in. ( $\varnothing 6 \times 100$  mm) measuring tube made of stainless steel, DIN W.-Nr. 1.4571, and a 4-20 mA sensor built into a type B head, DIN 43.729.

The connecting head is made of painted pressure-die-cast aluminium with Pg 16 screwed connection, stainless screws and neoprene rubber gasket.

The sensor is built into the system by means of a cutting ring bush or by means of one of the two matching sensor pockets  $\varnothing 0.36$  in.  $\times$  3.94 in. ( $\varnothing 9 \times 100$  mm) or  $\varnothing 0.36$  in.  $\times$  1.97 in. ( $\varnothing 9 \times 50$  mm).

The sensor pocket is made of stainless steel SINOX SSH 2 for  $\varnothing 0.24$  in. ( $\varnothing 6$  mm) measuring tube and has a G 1/2" process connection.

The cutting ring bush for  $\varnothing 0.24$  in. ( $\varnothing 6$  mm) measuring tube has a G 1/2" process connection.

Cutting ring bush or sensor pocket must be ordered separately.

### Dimensions

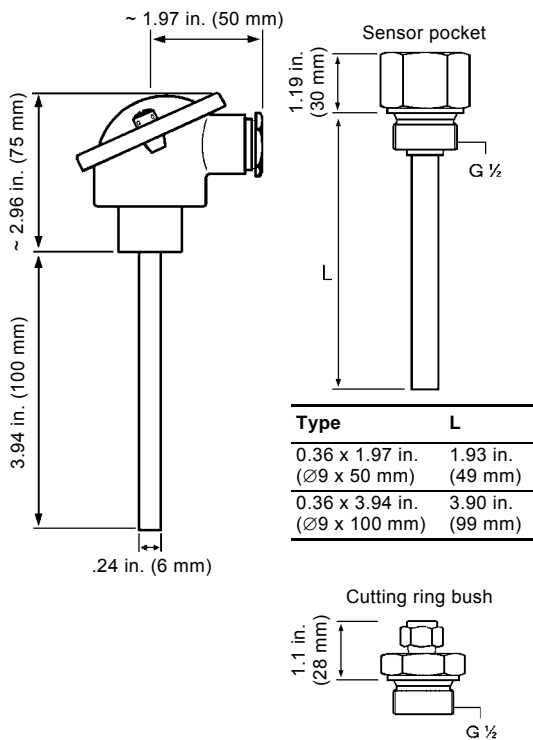

Fig. 70 Dimensions, TTA

### Wiring diagram

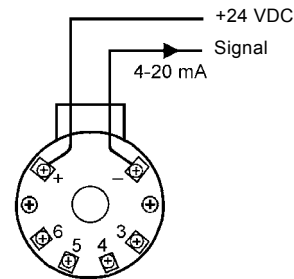

Fig. 71 Wiring diagram, TTA

### Technical data

Type	TTA	
Measuring accuracy	According to IEC 751, class B, 0.3 °C at 0 °C	
Response time <sup>3</sup>	Without sensor pocket:	28 seconds
	With oil-filled sensor pocket:	75 seconds
Enclosure class	IP55	
Output signal	4-20 mA	
Supply voltage	8.0 - 35.0 VDC	
EMC (electromagnetic compatibility)	Emission:	According to EN 61326
	Immunity:	According to EN 61326

**Note:** All sensors have a 4-20 mA output.

TM06 3683 0815 - TM06 3681 0815 - TM06 3682 0815

## Sensors, US units

Danfoss pressure sensor, cable not included	Type	Measuring range [psi (bar)]	Product number
Pressure connection: 1/4" - 18 NPT Electrical connection: DIN 43650 (plug not included)	MBS 3000	0-58 (0-4)	91136013
	MBS 3000	0-87 (0-6)	91136014
	MBS 3000	0-145 (0-10)	91136015
	MBS 3000	0-232 (0-16)	91136016
	MBS 3000	0-362 (0-25)	91136017
	MBS 3000	0-580 (0-40)	91136018
	MBS 3000	0-870 (0-60)	91136019
Danfoss pressure sensor, 6.5 ft (2 m) screened cable			
Pressure connection: 1/2" - 14 NPT	MBS 3000	0-120 (0-8)	96437852
Grundfos differential pressure sensor, 3 ft (0.9 m) screened cable			
Pressure connection: 7/16" flare	DPI	0-20 (0-6)	96624396
	DPI	0-33 (0-10)	96624397
	DPI	0-54 (0-16)	96624398
	DPI	0-84 (0-25)	96624399
	DPI	0-200 (0-60)	96624441
	DPI	0-334 (0-101)	96624442

**Note:** All sensors have a 4-20 mA output.

## Pt100 temperature sensors

Pt100 temperature sensor	Type	Measuring range	Product number
With 65 ft (20 m) cable	-	-	96408957
With 131 ft (40 m) cable	-	-	96408684
With 196 ft (60 m) cable	-	-	96408958
With 262 ft (80 m) cable	-	-	96408959
With 328 ft (100 m) cable	-	-	96408960
With 65 ft (20 m) cable	-	-	96437784
With 131 ft (40 m) cable	-	-	96437785
With 196 ft (60 m) cable	-	-	96437786
With 262 ft (80 m) cable	-	-	96437787
With 328 ft (100 m) cable	-	-	96437788
Pt100 temperature sensor and cable extension			
Pt100	-	-	95043173
Cable extension <sup>1)</sup>	-	-	00RM5271
Cable extension, unassembled option <sup>1)</sup>	-	-	96571480
Cable extension, assembled option <sup>1)</sup>	-	-	96763223

<sup>1)</sup> State length when ordering.

## Other accessories

Dry-running protection <sup>1)</sup>	Type	Product number
Module, sensor, 16 ft (5 m) cable, 200-240 V <sup>2)</sup>	LiqTec	96443674
Module, sensor, 16 ft (5 m) cable, 80-130 V <sup>2)</sup>	LiqTec	96443912
Extension cable, 49 ft (15 m)		96443676

<sup>1)</sup> Main pump types CR, CRI, CRN, MTR, SPK, CRK and CHI.

<sup>2)</sup> Sensor connection: 1/2".

# 12. Grundfos Product Center

Grundfos Product Center is an online search and sizing tool to help you make the right choice.

<http://product-selection.grundfos.com>



**SIZING** enables you to size a pump based on entered data and selection choices.

**REPLACEMENT** enables you to find a replacement product. Search results will include information on

- the lowest purchase price
- the lowest energy consumption
- the lowest total life cycle cost.

**CATALOG** gives you access to the Grundfos product catalog.

**LIQUIDS** enables you to find pumps designed for aggressive, flammable or other special liquids.

<p><b>All the information you need in one place</b></p> <p>Performance curves, technical specifications, pictures, dimensional drawings, motor curves, wiring diagrams, spare parts, service kits, 3D drawings, documents, system parts. The Product Center displays any recent and saved items — including complete projects — right on the main page.</p>	<p><b>Downloads</b></p> <p>On the product pages, you can download Installation and Operating Instructions, Data Booklets, Service Instructions, etc. in PDF format.</p>
-------------------------------------------------------------------------------------------------------------------------------------------------------------------------------------------------------------------------------------------------------------------------------------------------------------------------------------------------------------	-------------------------------------------------------------------------------------------------------------------------------------------------------------------------

Subject to alterations.

# Grundfos GO

## Mobile solution for professionals on the GO!

Grundfos GO is the mobile tool box for professional users on the go. It is the most comprehensive platform for mobile pump control and pump selection including sizing, replacement and documentation. It offers intuitive, handheld assistance and access to Grundfos online tools, and it saves valuable time for reporting and data collection.

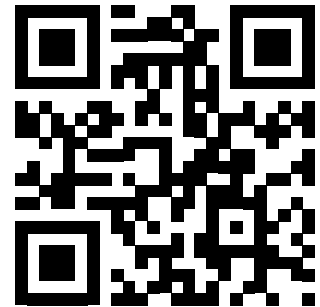
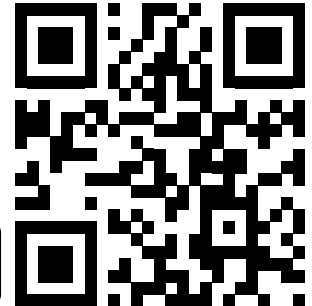





L-CUE-PG-01

<b>98864240</b> 0415
----------------------

ECM: 1153145
--------------

**GRUNDFOS Chicago**

3905 Enterprise Court  
P.O. Box 6620  
Aurora, IL 60598-0620  
Phone: +1-630-236-5500  
Telefax: +1-630-236-5511

**GRUNDFOS Kansas City**

17100 West 118th Terrace  
Olathe, Kansas 66061  
Phone: +1-913 227 3400  
Telefax: +1-913 227 3500

**GRUNDFOS CBS**

902 Koomey Road  
Brookshire, TX 77423  
Phone: (281) 994-2700  
Fax: (800) 945-4777

**GRUNDFOS Indianapolis**

2005 Dr. Martin Luther King, Jr. Street  
Indianapolis, IN 46202  
Phone: (317) 925-9661  
Fax: (317) 924-7388

[www.grundfos.us](http://www.grundfos.us)

**Canada**

GRUNDFOS Canada  
2941 Brighton Road  
Phone: +1-905 829 9533  
Telefax: +1-905 829 9512

[www.grundfos.ca](http://www.grundfos.ca)

**México**

GRUNDFOS México  
Boulevard TLC No. 15  
Parque Industrial Stiva Aeropuerto  
Phone: +011-52-81-8144 4000  
Telefax: +011-52-81-8144 4010

[www.grundfos.mx](http://www.grundfos.mx)