

NOZZLE LIST

Mark	Size	PN	Connections Standard	Service	From q
N1	2"	/	NPT 2"(female)	Inlet	See Dwg.
N2	2"	/	NPT 2"(female)	Outlet	See Dwg.
N3	M20 GB	/	M20 GB	Vent	See Dwg.
OPTION					2" ANSI FLANGE ADAPTORS AVAILABLE

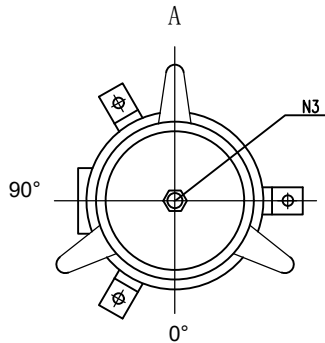

DESIGN PRESS.: bar (psi)	6 (85psi)	NO. OF FILTER ELEMENTS:	1
DESIGN TEMP.: Degrees C (F)	43 (109)	FILTRATION AREA: M2 (FT ²)	0.25 (2.7 M ²)
HYDRO TEST PRESS.: bar (psi)	2.9 (42psi)	FILTER ELEMENT SIZE: mm (in)	Ø152.5x559(Ø6"x21")
WORKING PRESS.: bar (psi)	/	EMPTY WEIGHT: kg (lb)	4 (9lbs)
WORKING TEMP.: Degrees C (F)	/	GASKET MATERIAL:	VITON
CLEAN PRESS. DROP: bar (psi)	0.1 (1.5psi)	MAX REC PRESS. DROP: bar (psi)	1.38 (20psi)
FLOW RATE: LPH (USGPM)	2044 (90)	CORROSION ALLOW: mm (in)	0
MATERIAL OF CONST.:	Polypropylene	MAX.ALLOW PRESS. DROP: bar (psi)	1.38 (20psi)

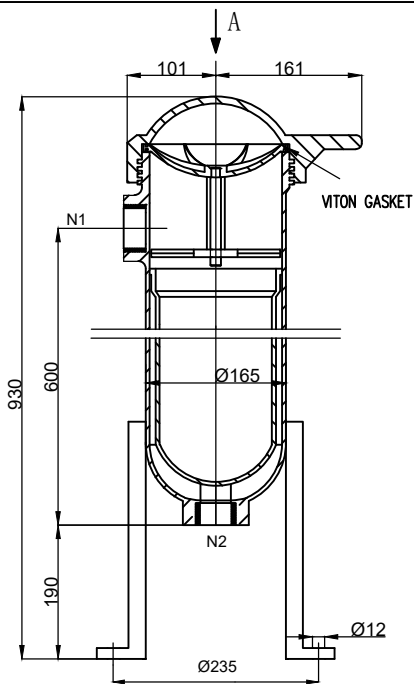

187 Robert Street East
 Penetanguishene, Ontario, CANADA, L9M 1G9
 www.liquidfiltration.com 1.705.549.9777

TITLE: Size 5 Side Entry Filter Vessel	MODEL: SB51N28-85	MATERIAL: POLYPROPYLENE
DRAW.NO.: 210216-1	REV.NO.: 0	WEIGHT: 4kg (9lbs)
DRAWN BY: K.W.	CHECKED BY: L.D.	DATE: 2021/02/16
THIS DRAWING IS THE SOLE PROPERTY OF INDUSTRIAL FILTER MANUFACTURING LIMITED (IFM) UNAUTHORIZED DUPLICATION IS NOT PERMITTED WITHOUT PRIOR WRITTEN CONSENT FROM IFM		